

1.

M1862\_06

rauch

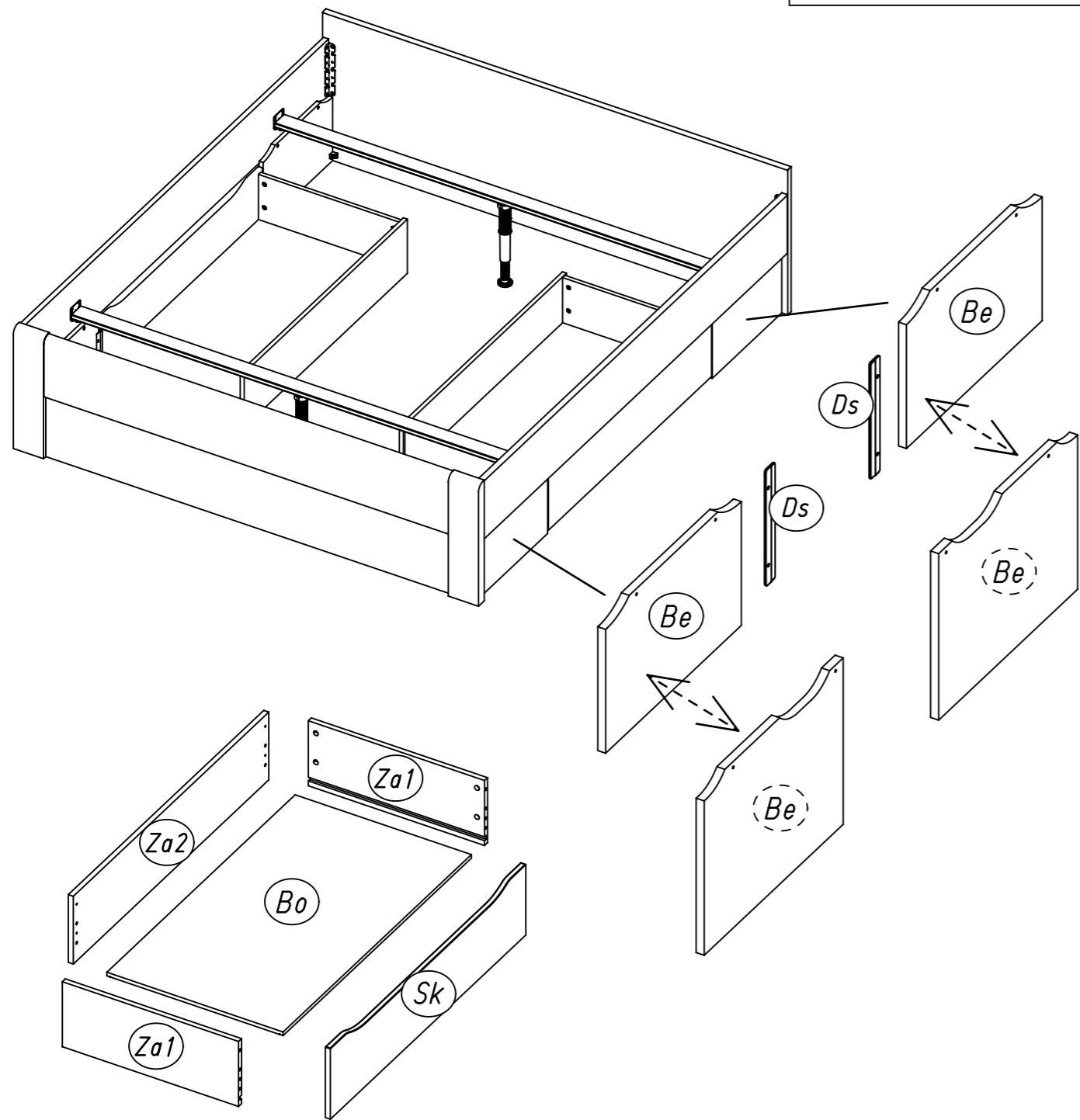
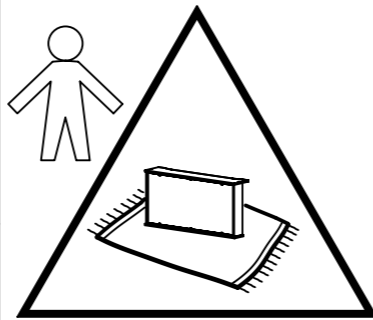
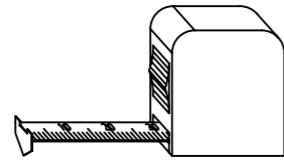
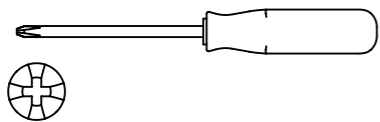

2.

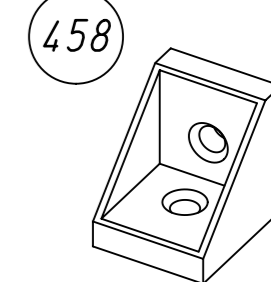
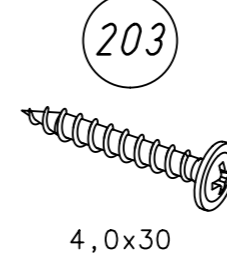
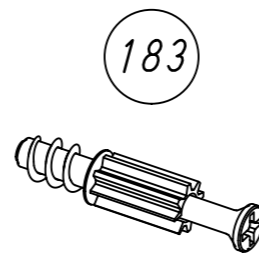
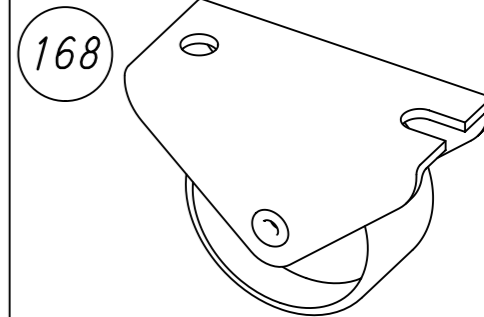
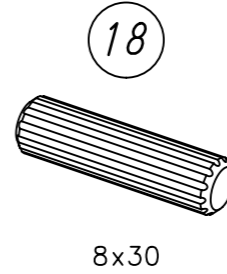
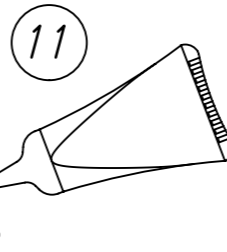

1 18

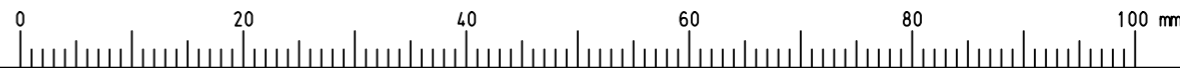
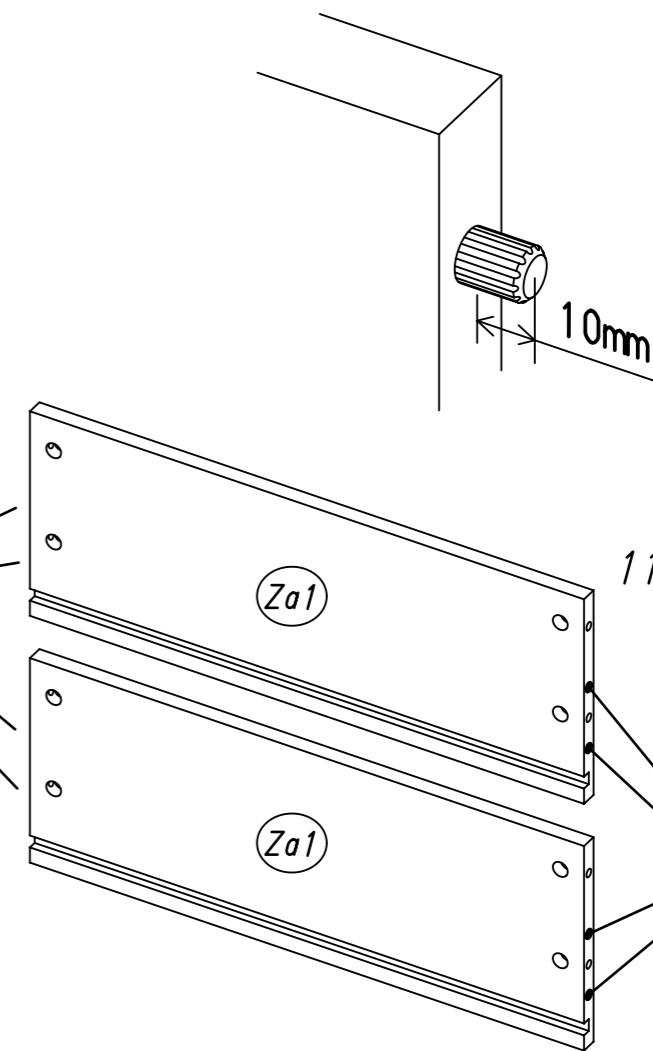
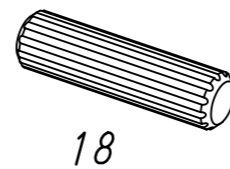
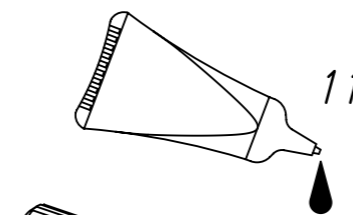

3.

2 349

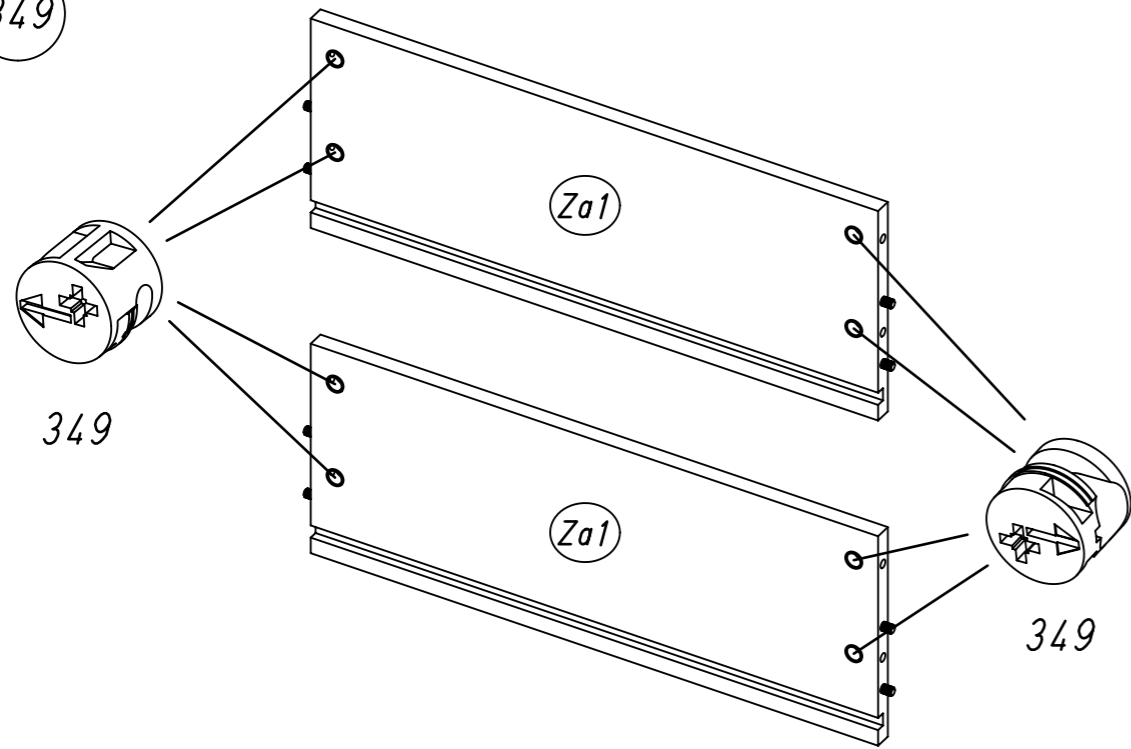

4.

4

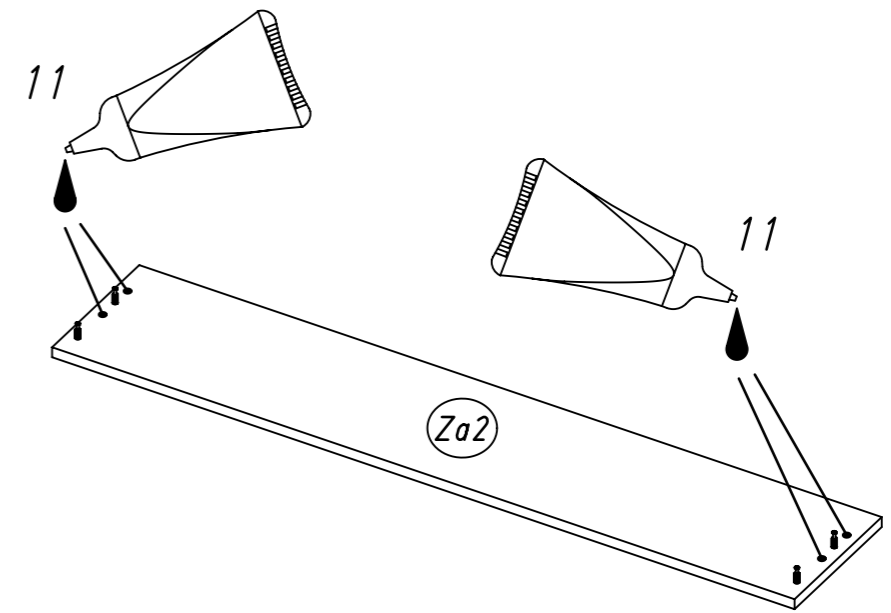

3 183

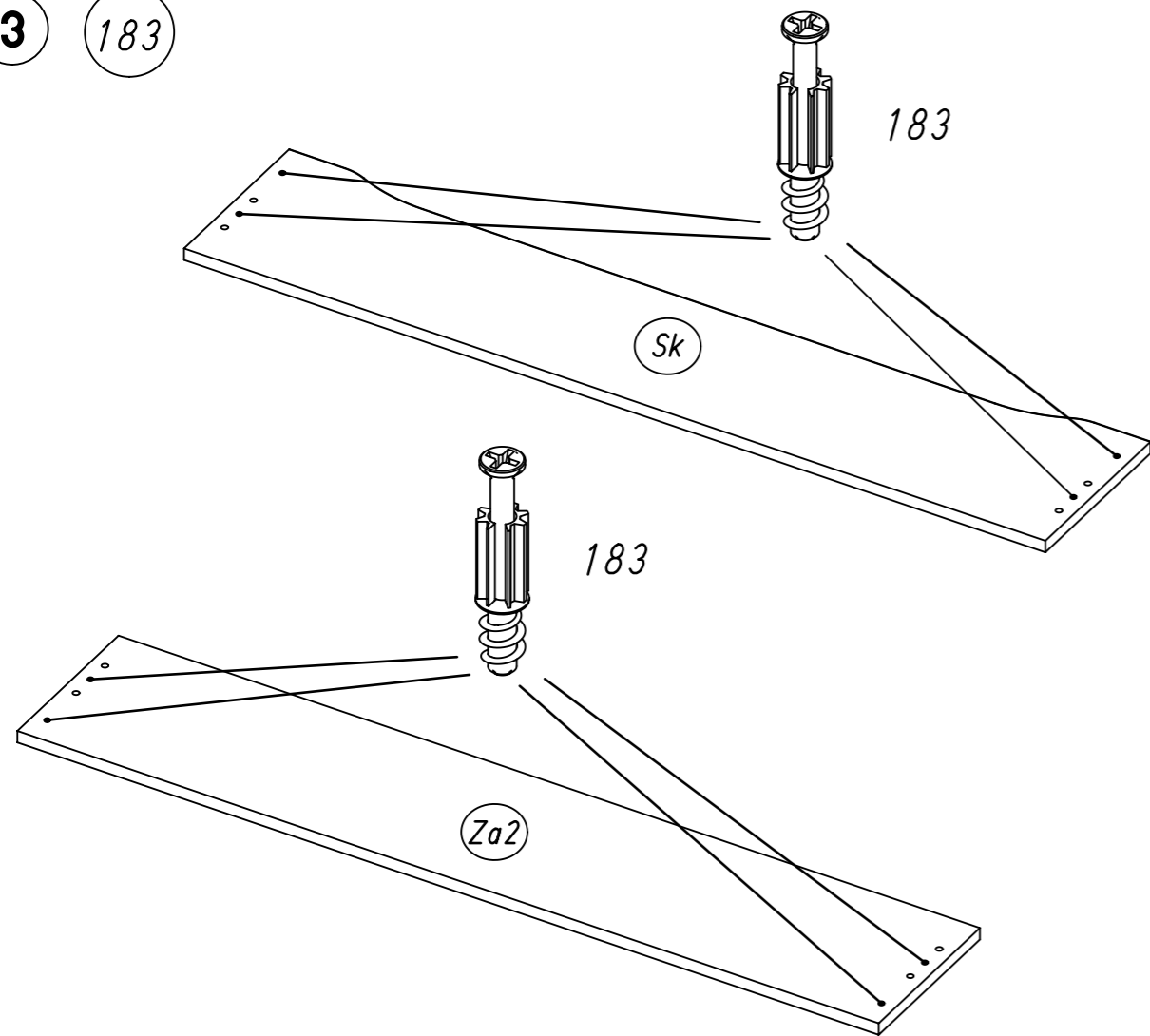

5

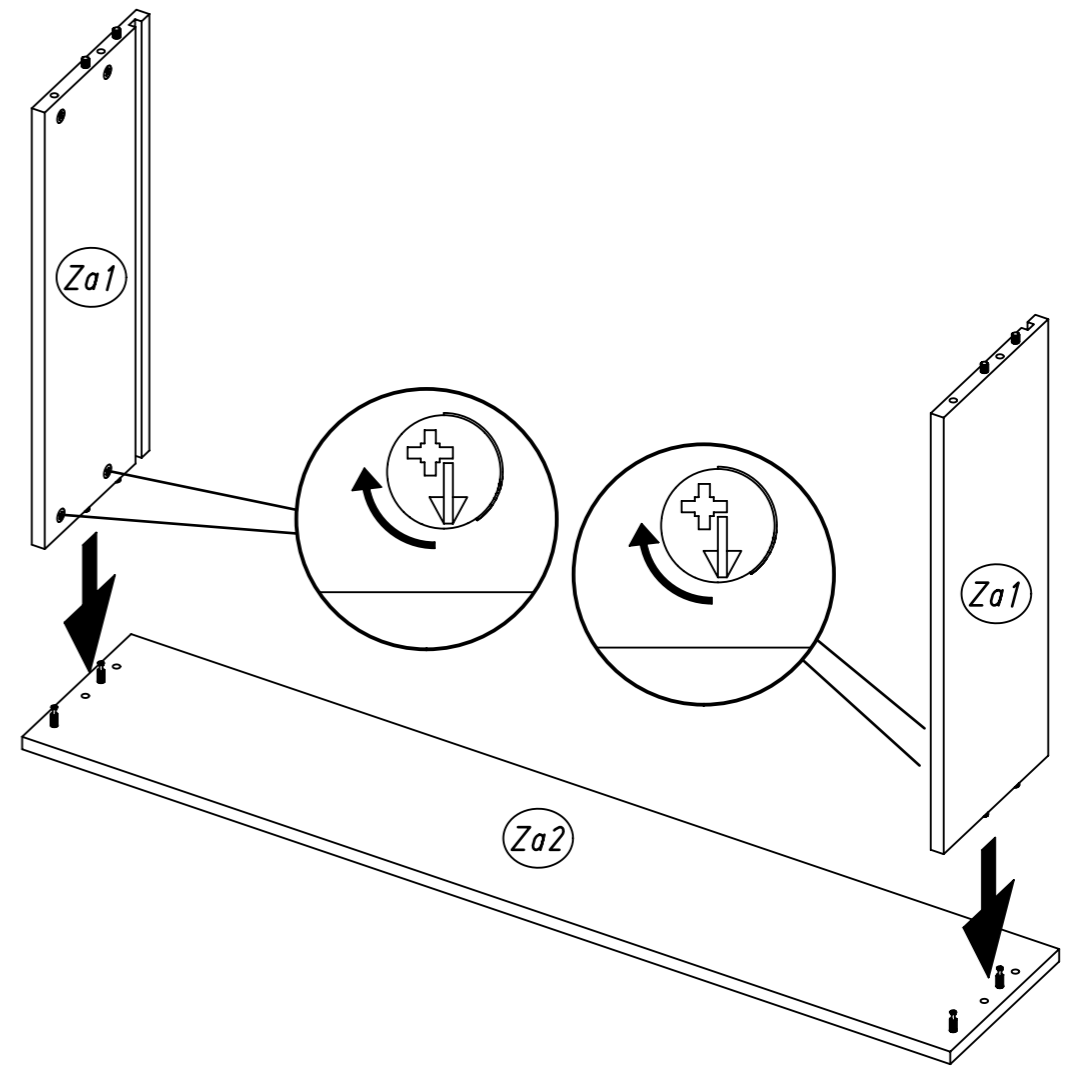

6

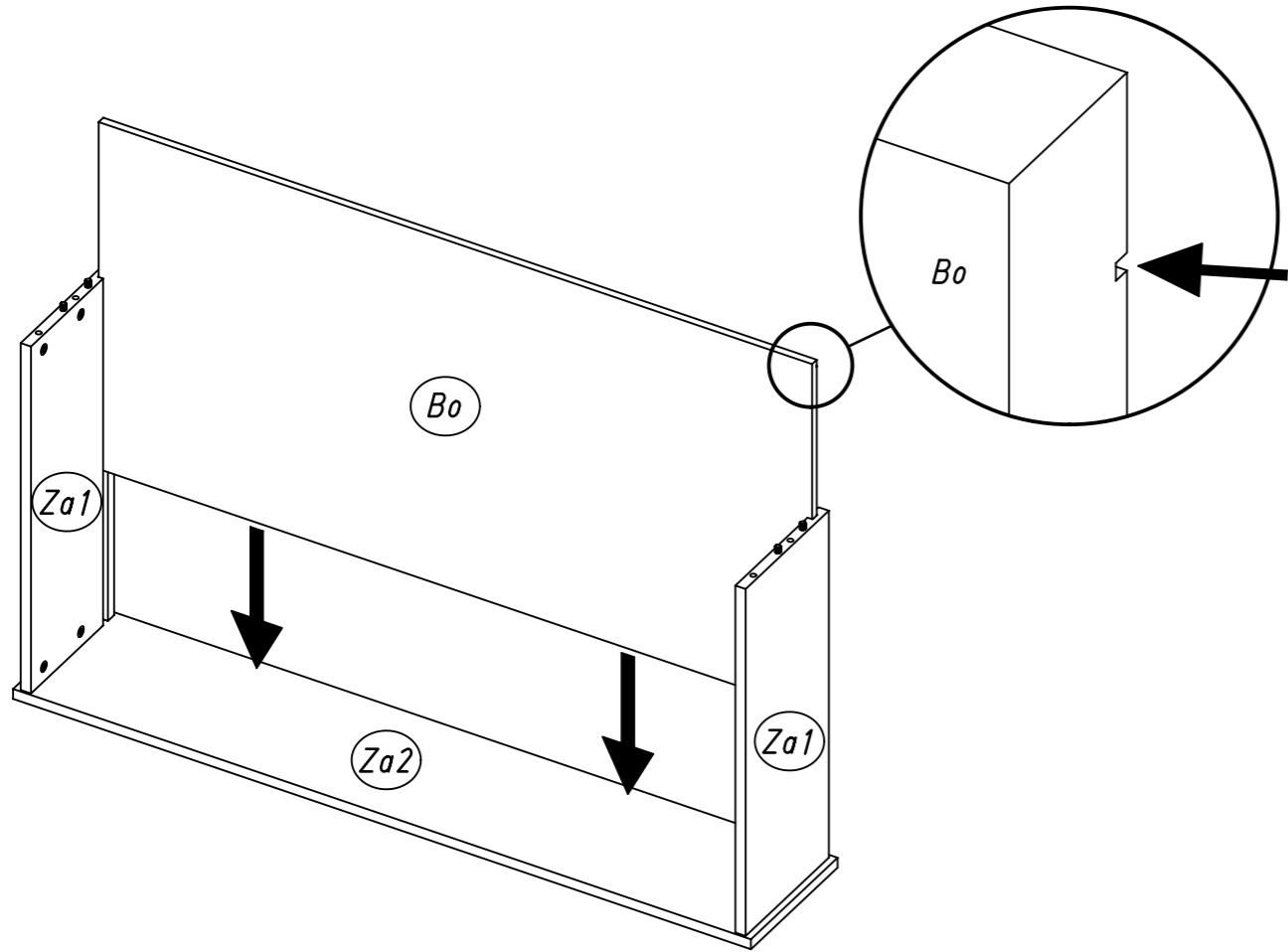

8

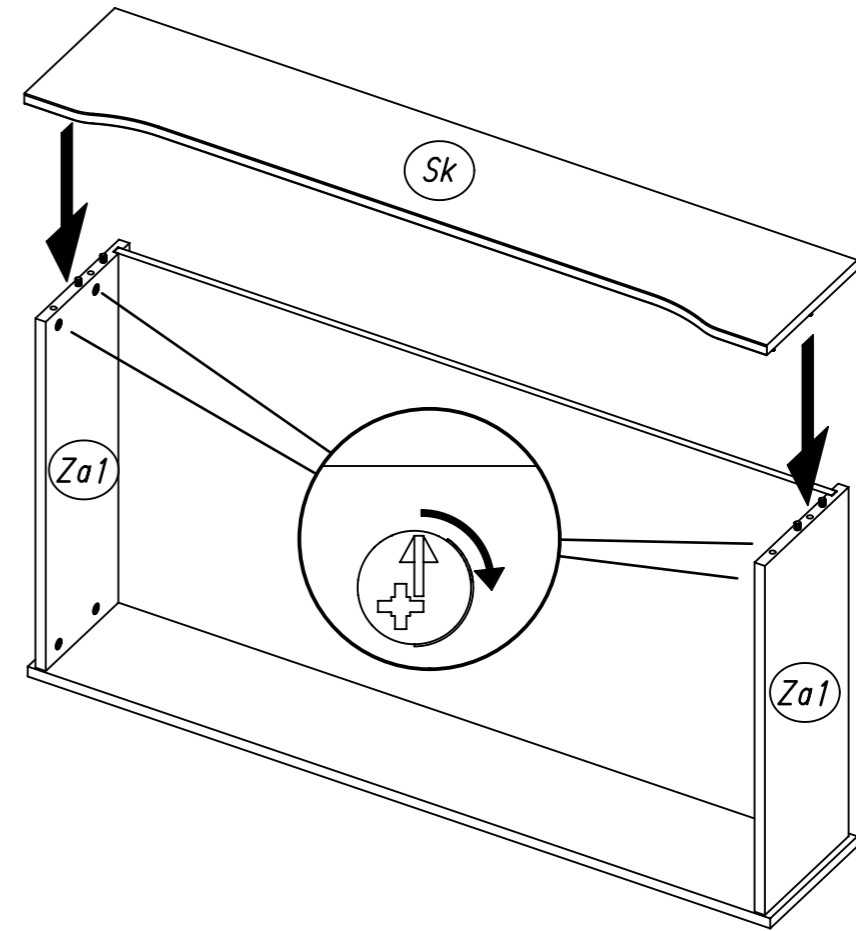

7

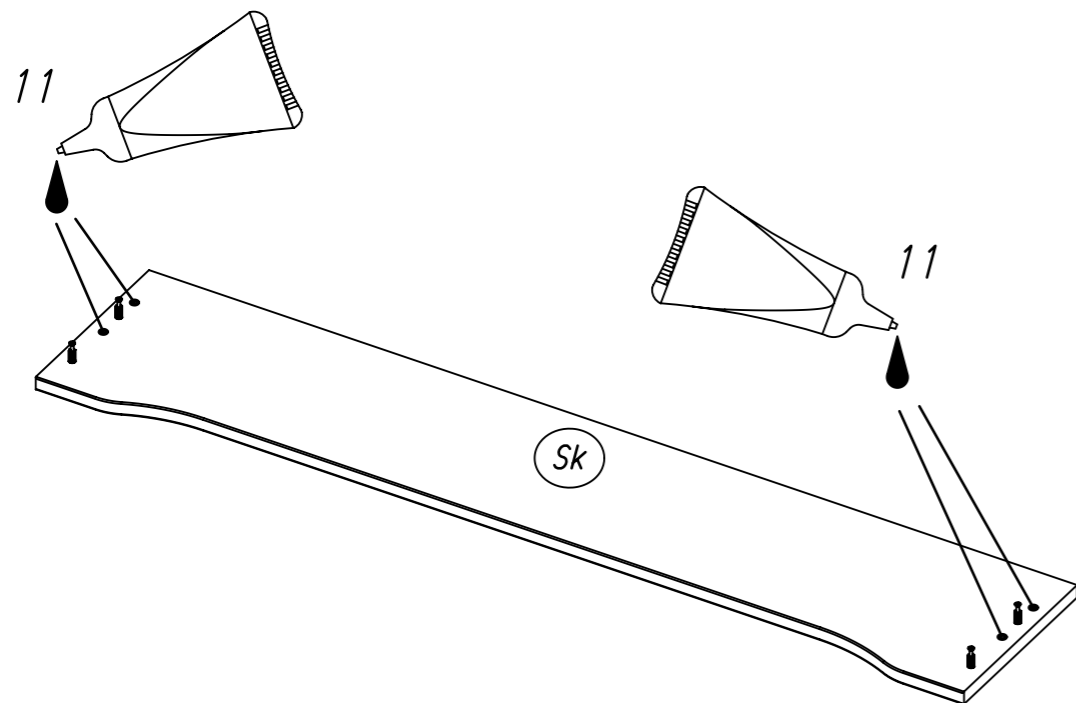

9 168 88

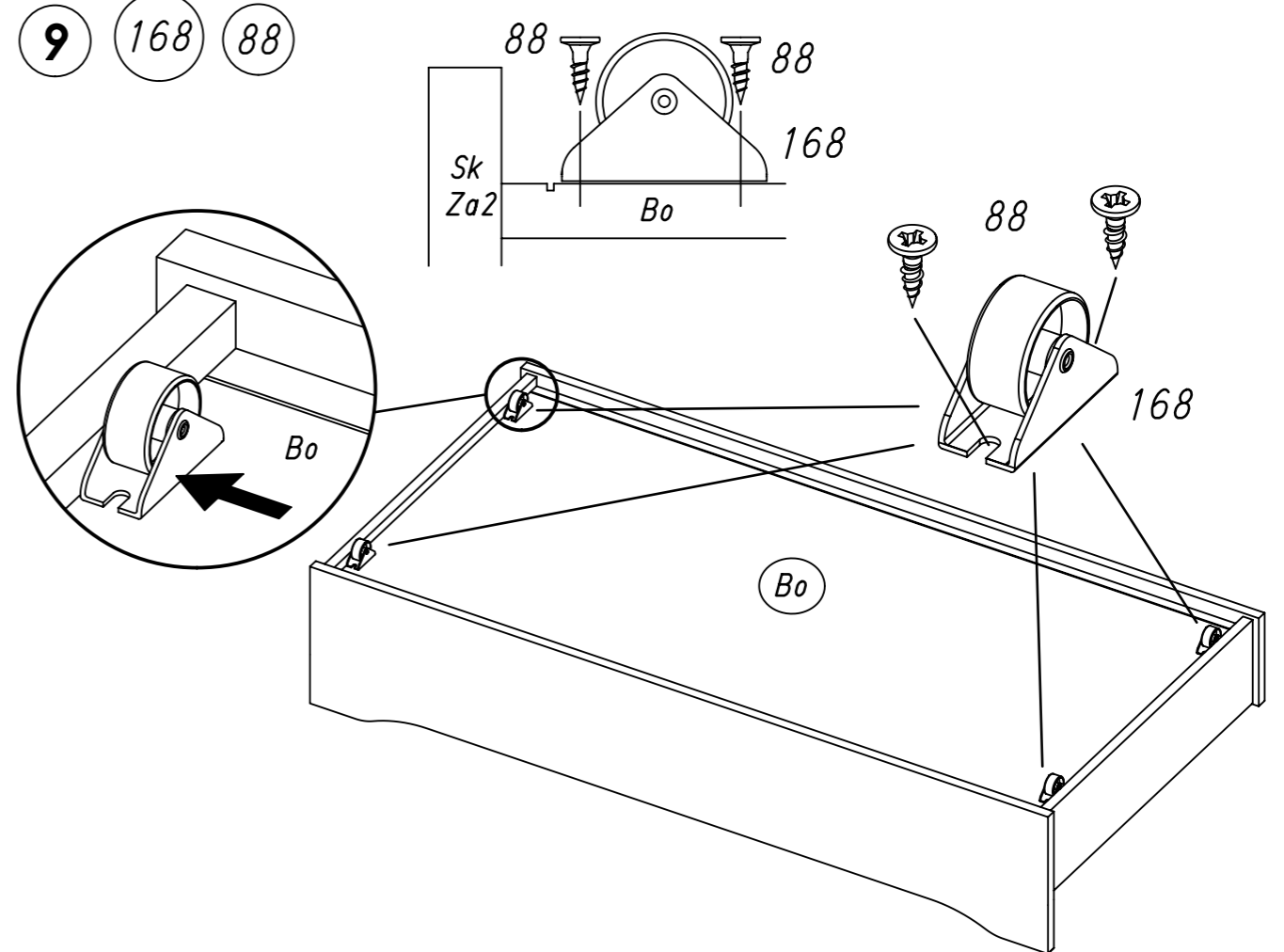

10 458 205

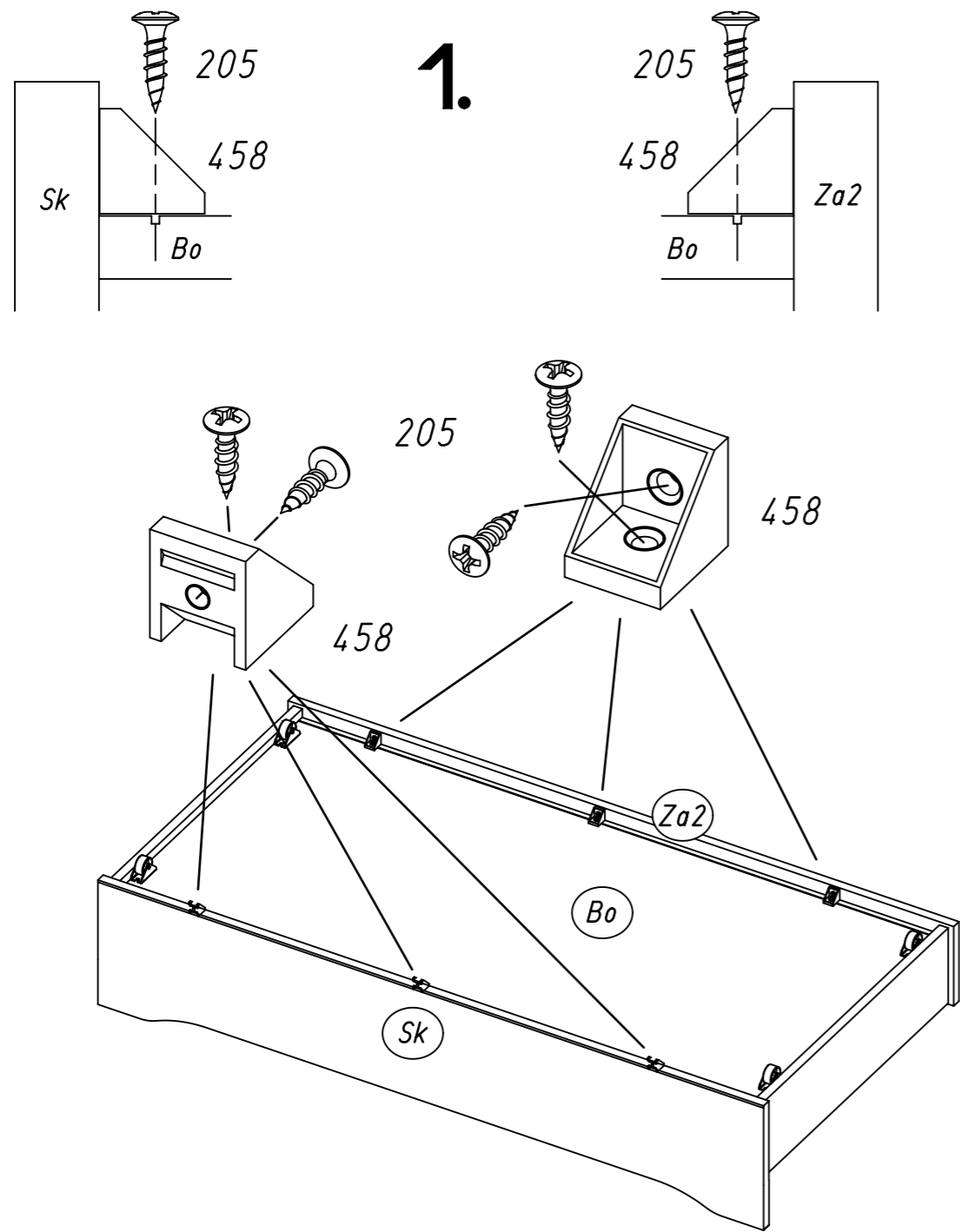

2.



11 203

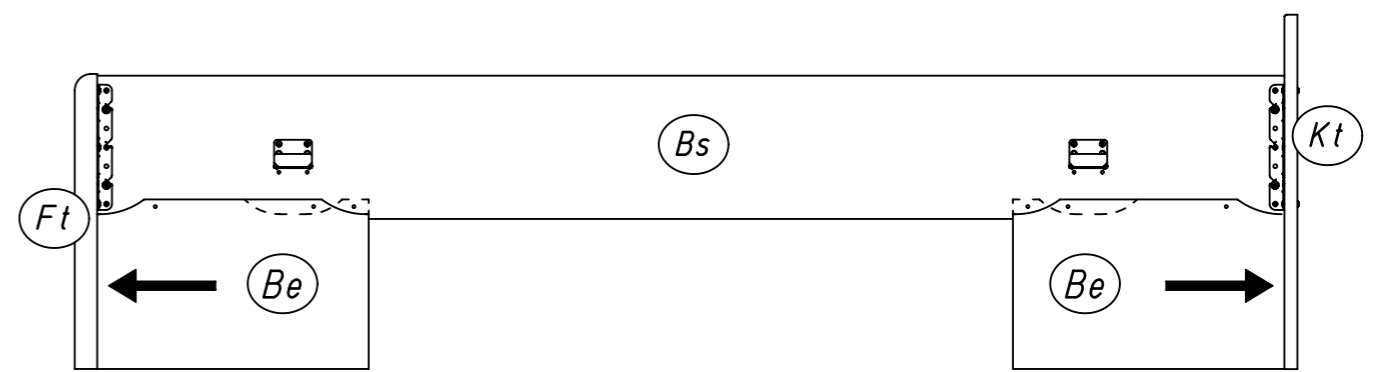
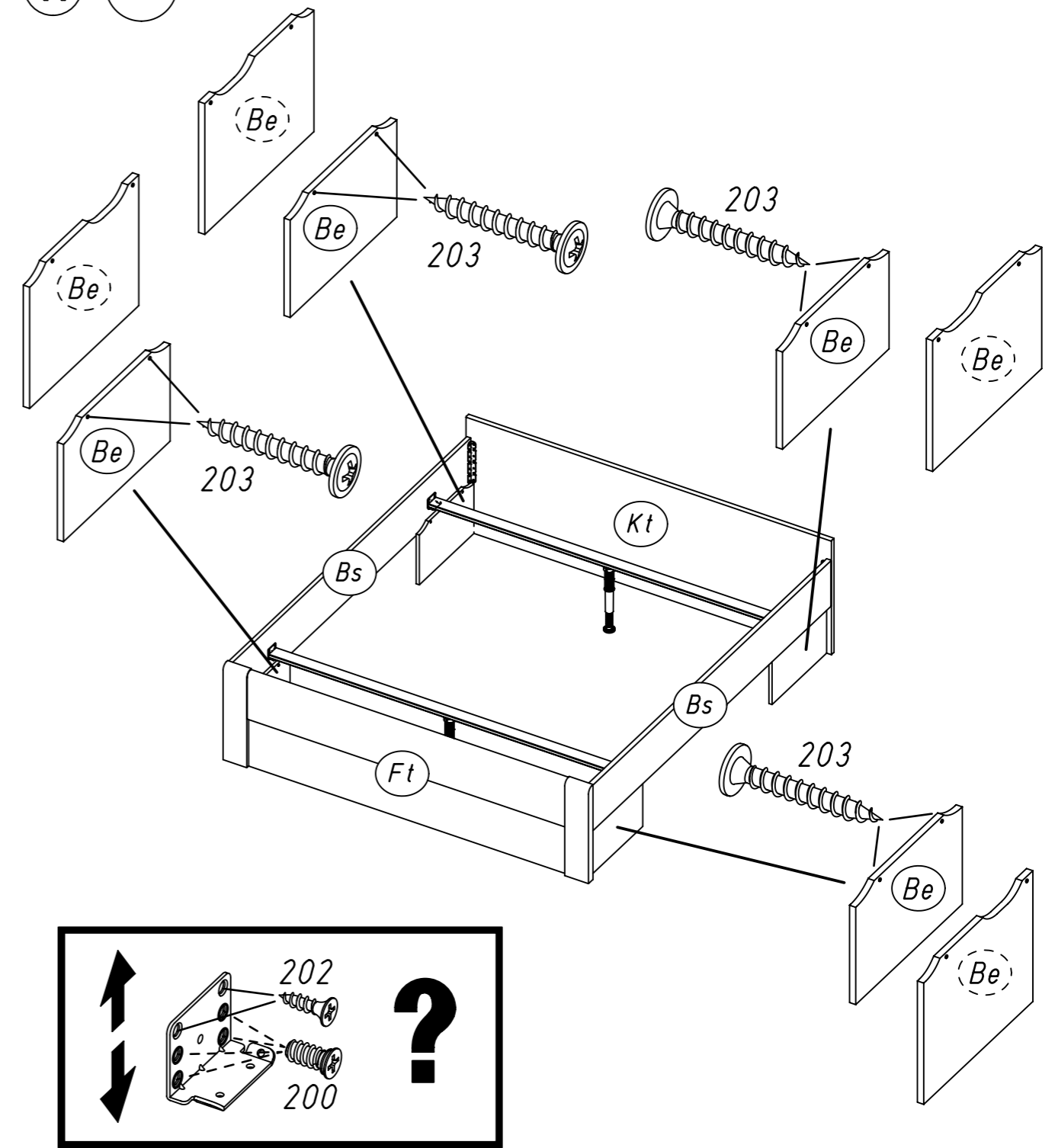

12 458 205

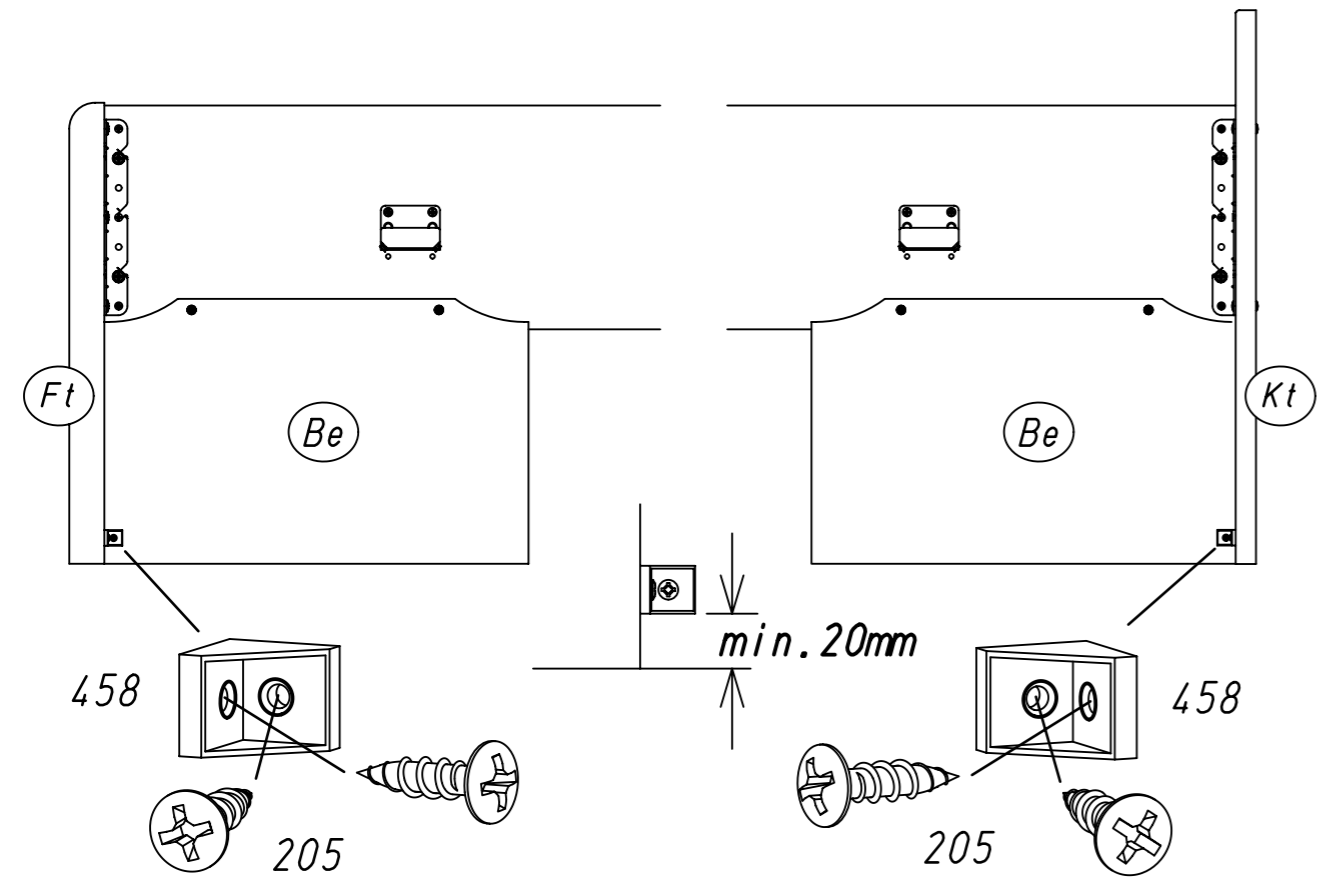
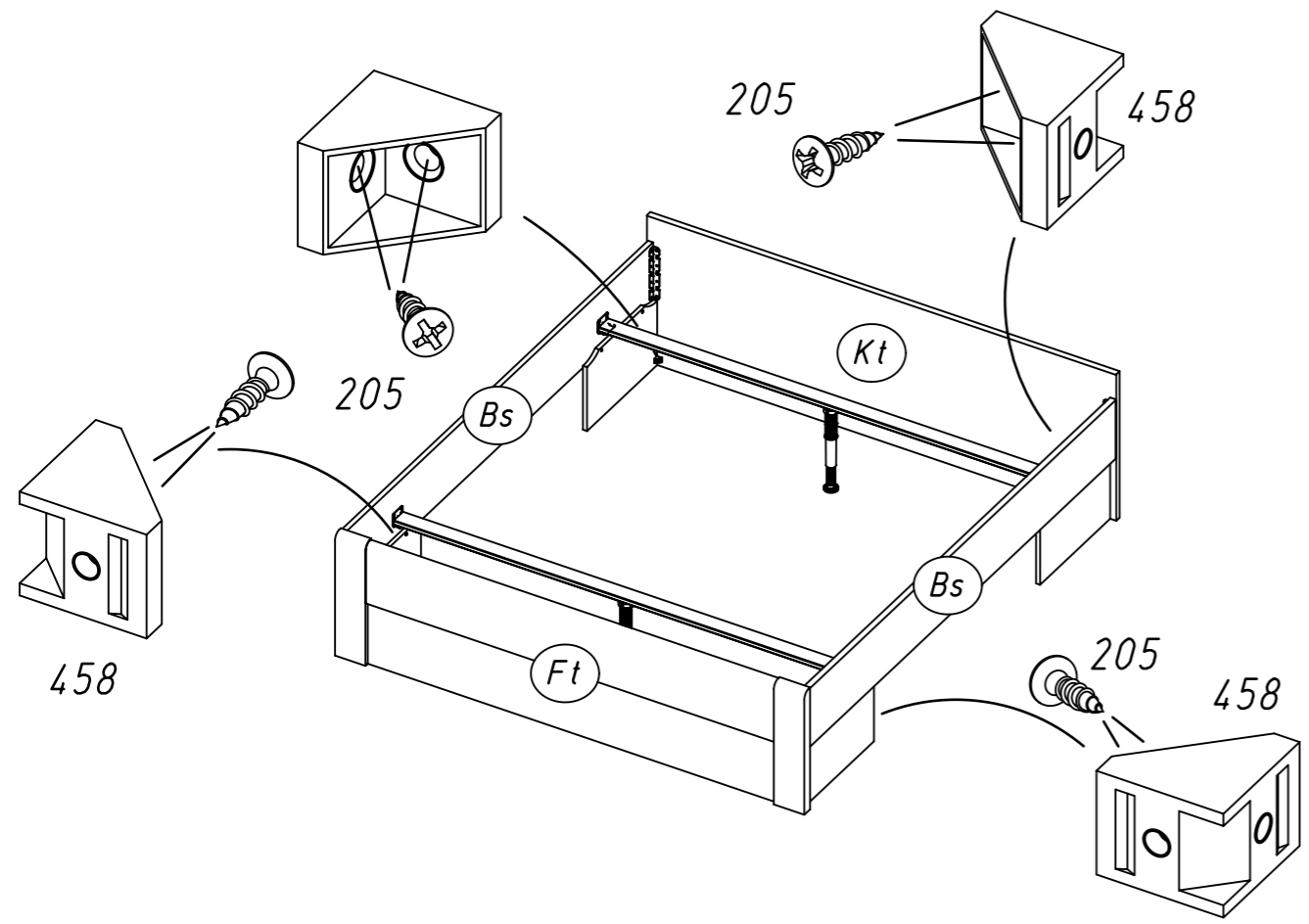

13 205

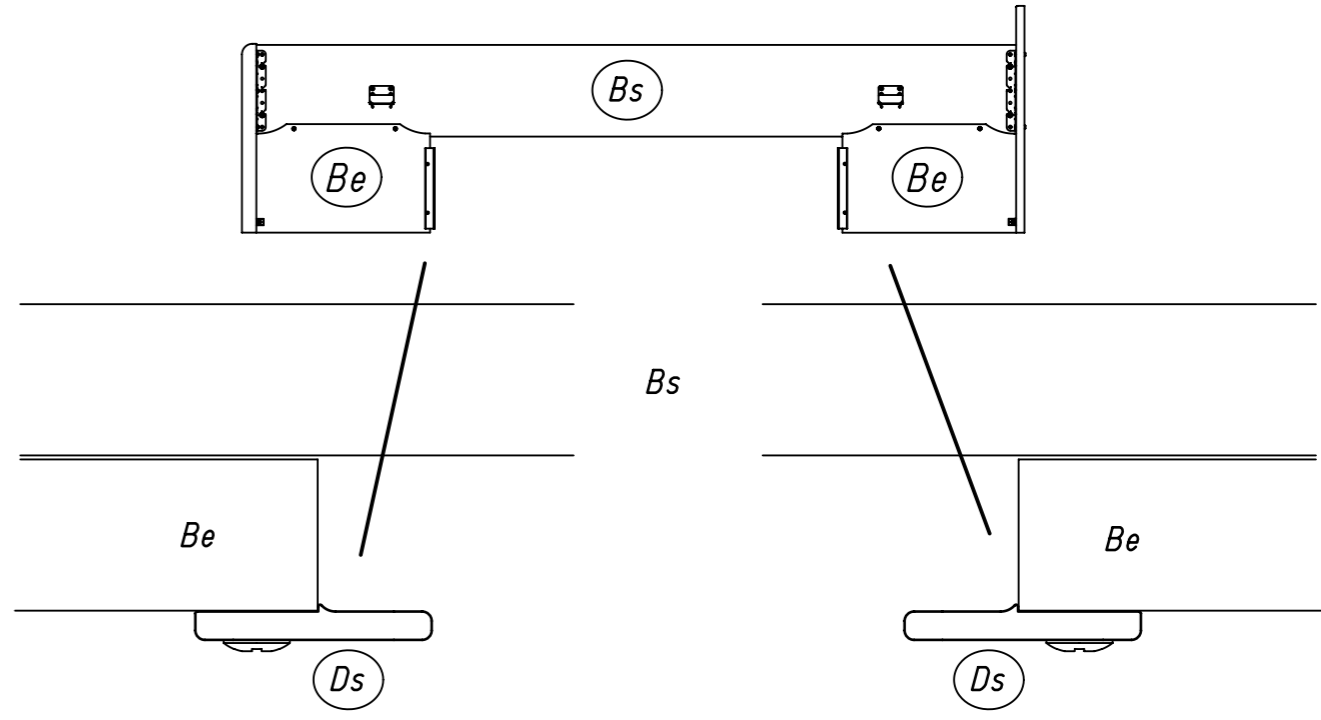
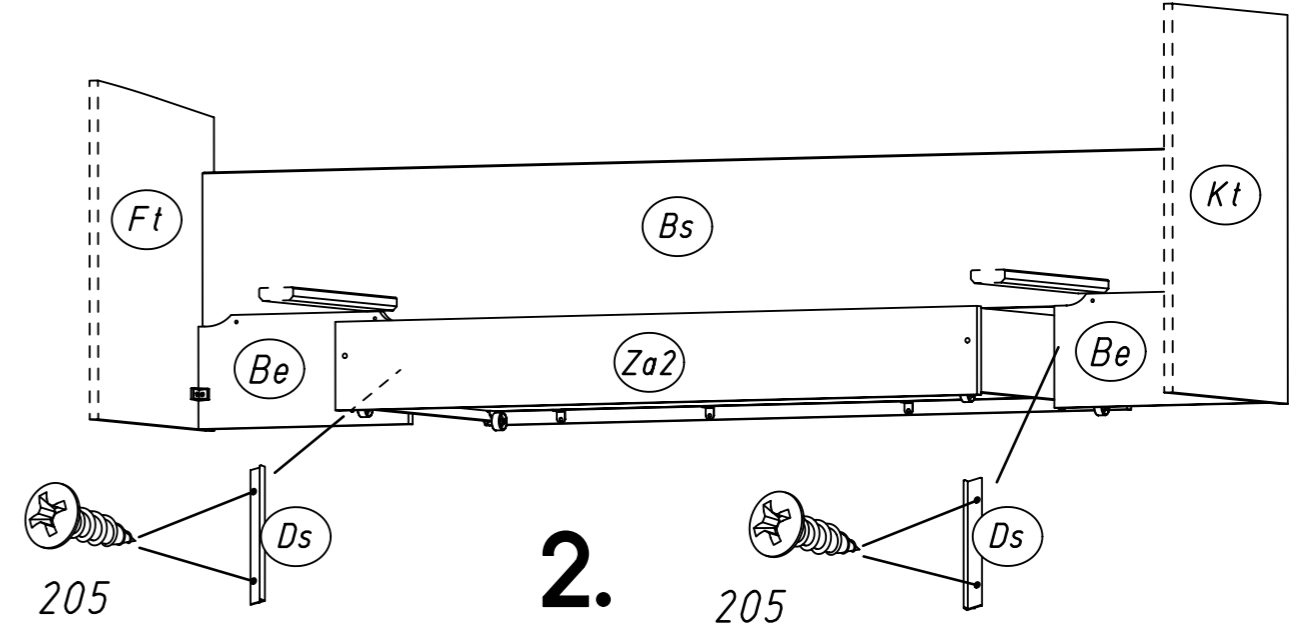
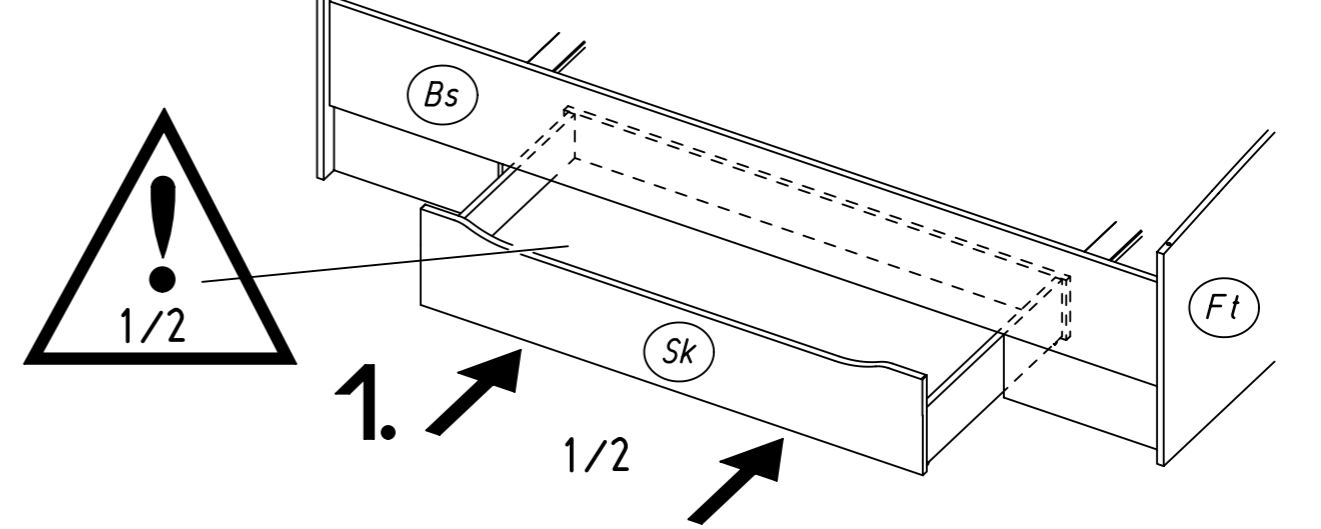

14

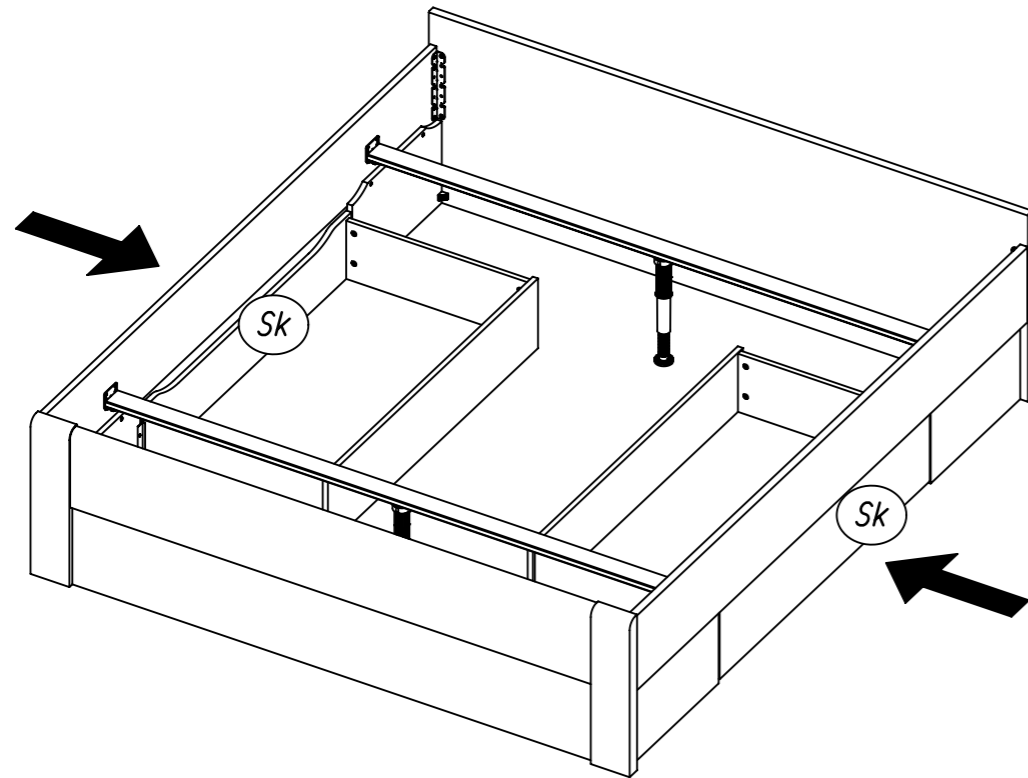
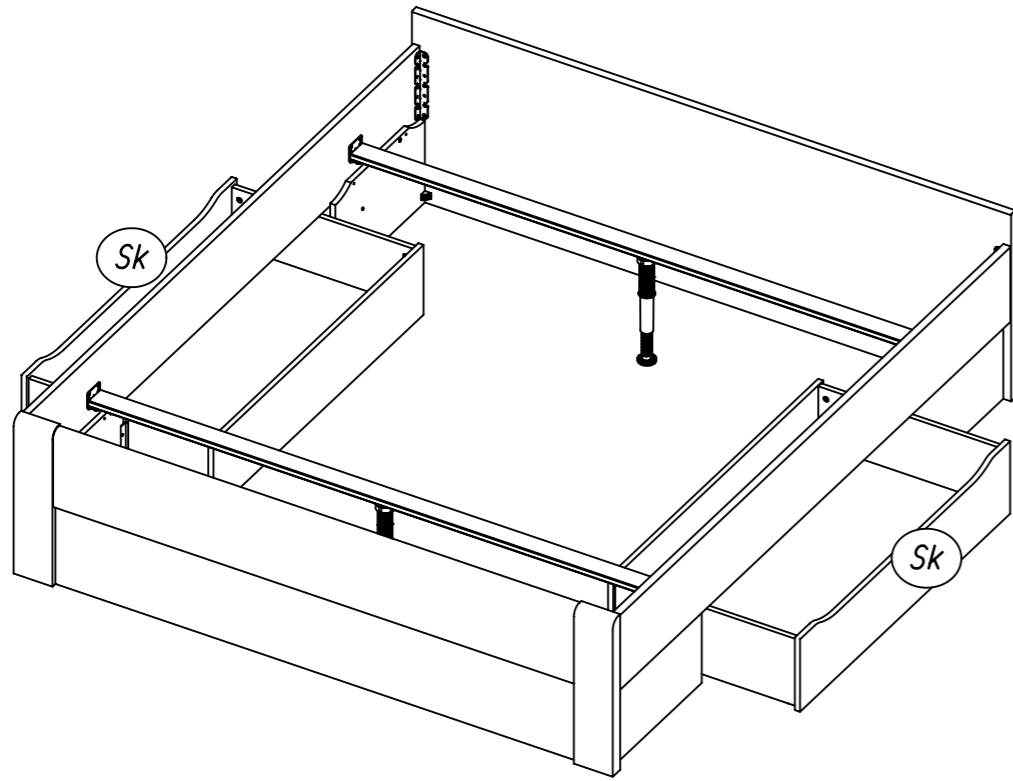

1.

M1867\_01

rauch

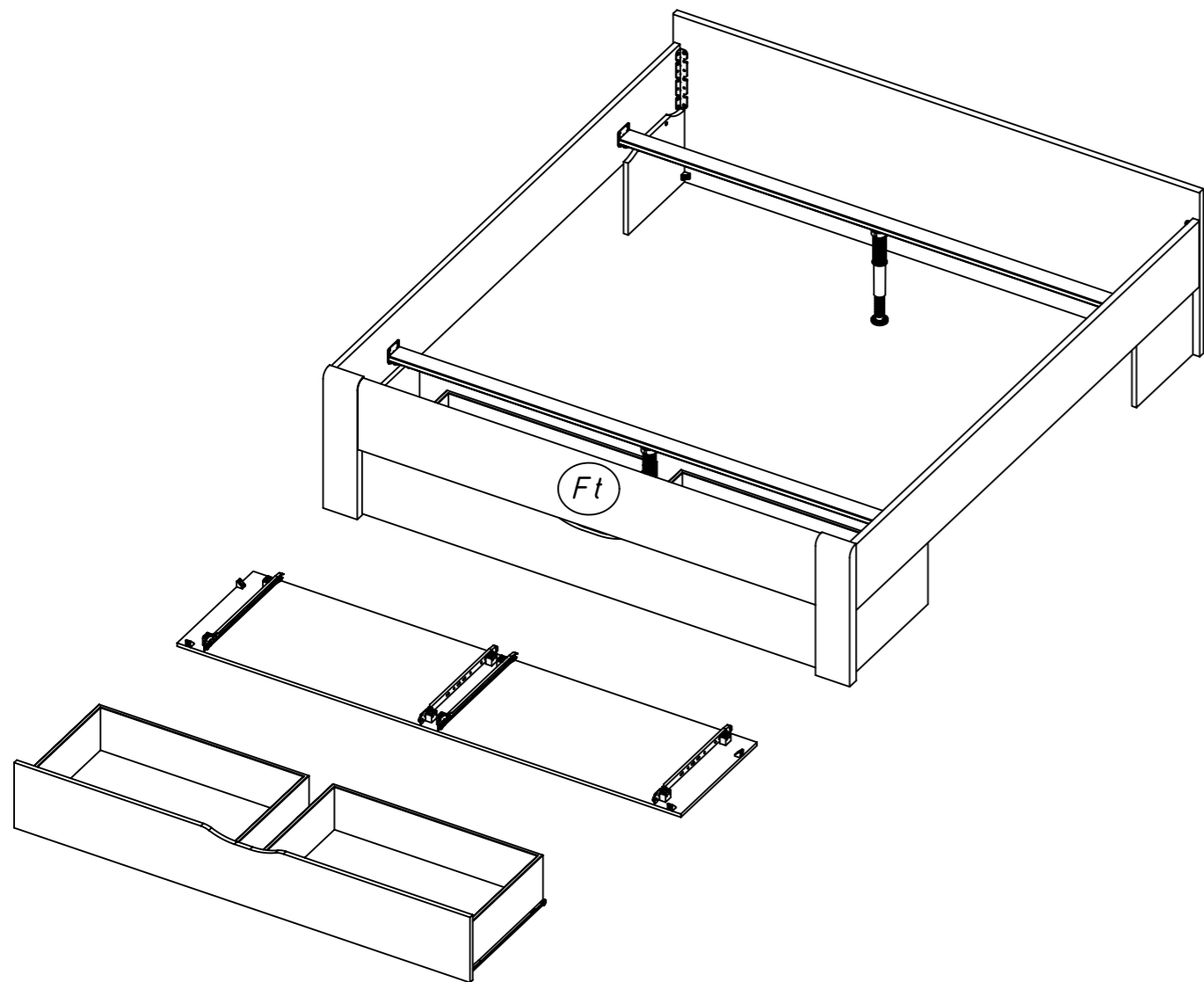
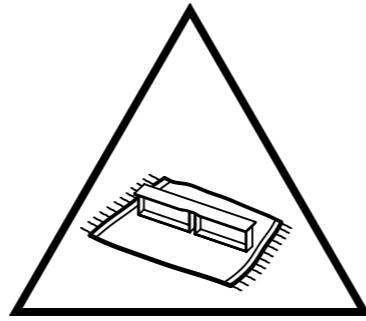
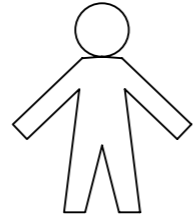
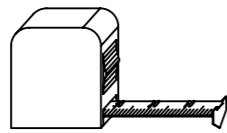
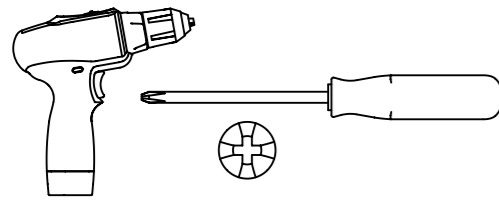

2.

11

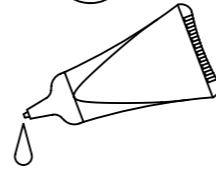

94

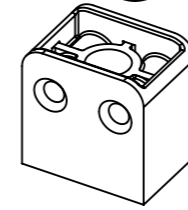

201

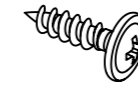

4x15

208

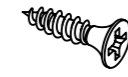

3,5x15

227



6x10

242

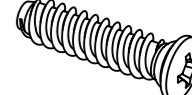

6,3x25

255

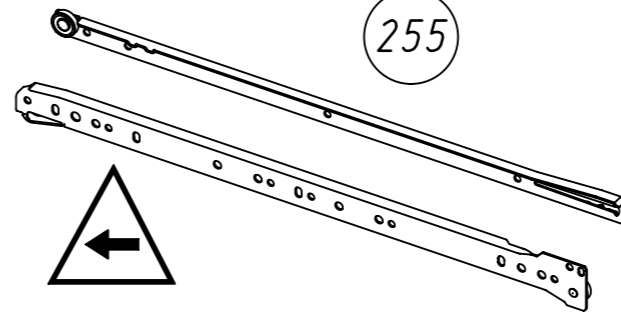

256

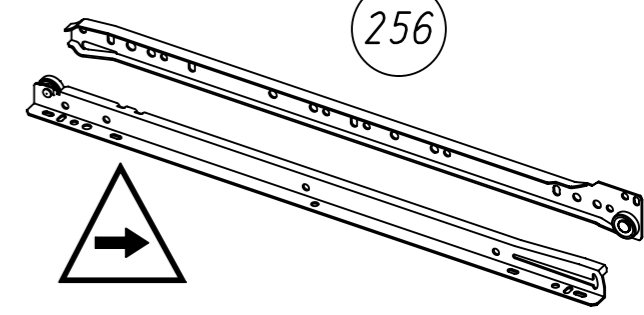

458

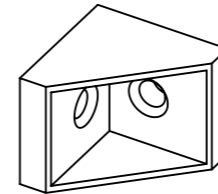

Bo

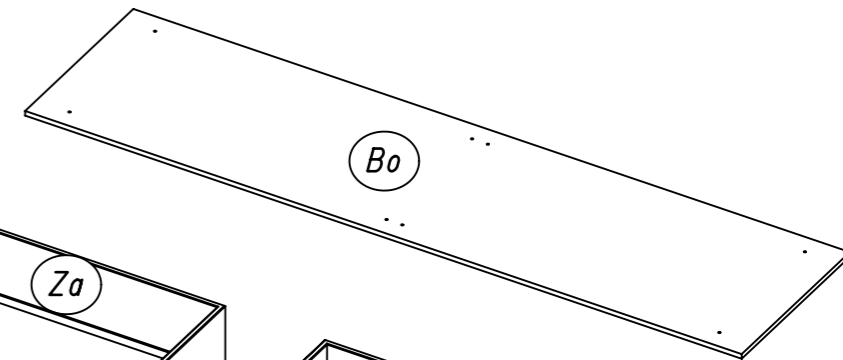

Za

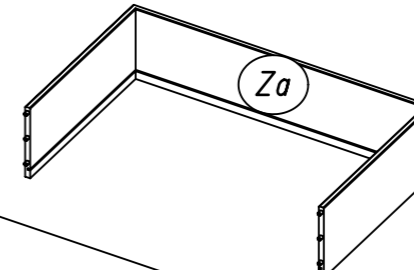

Za

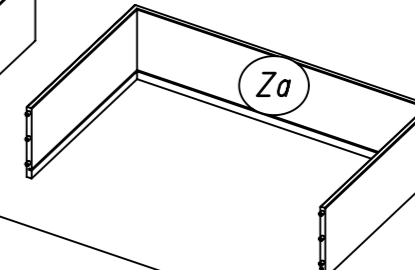

Sb

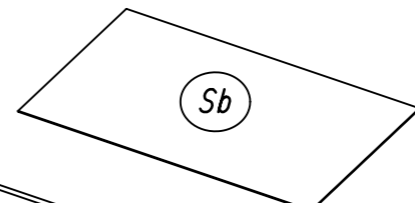

Sb

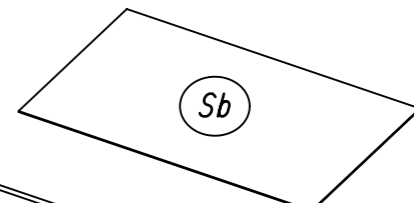

Sk

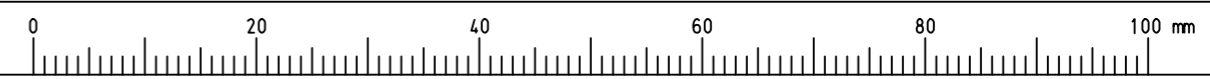
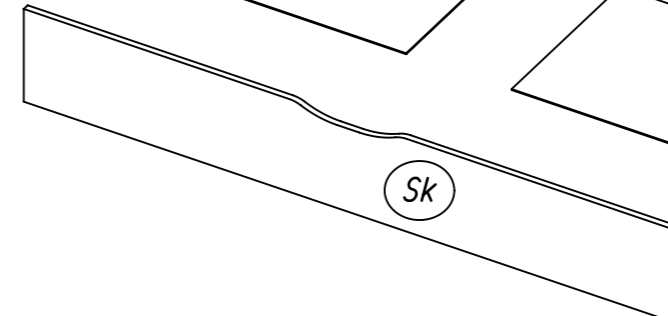

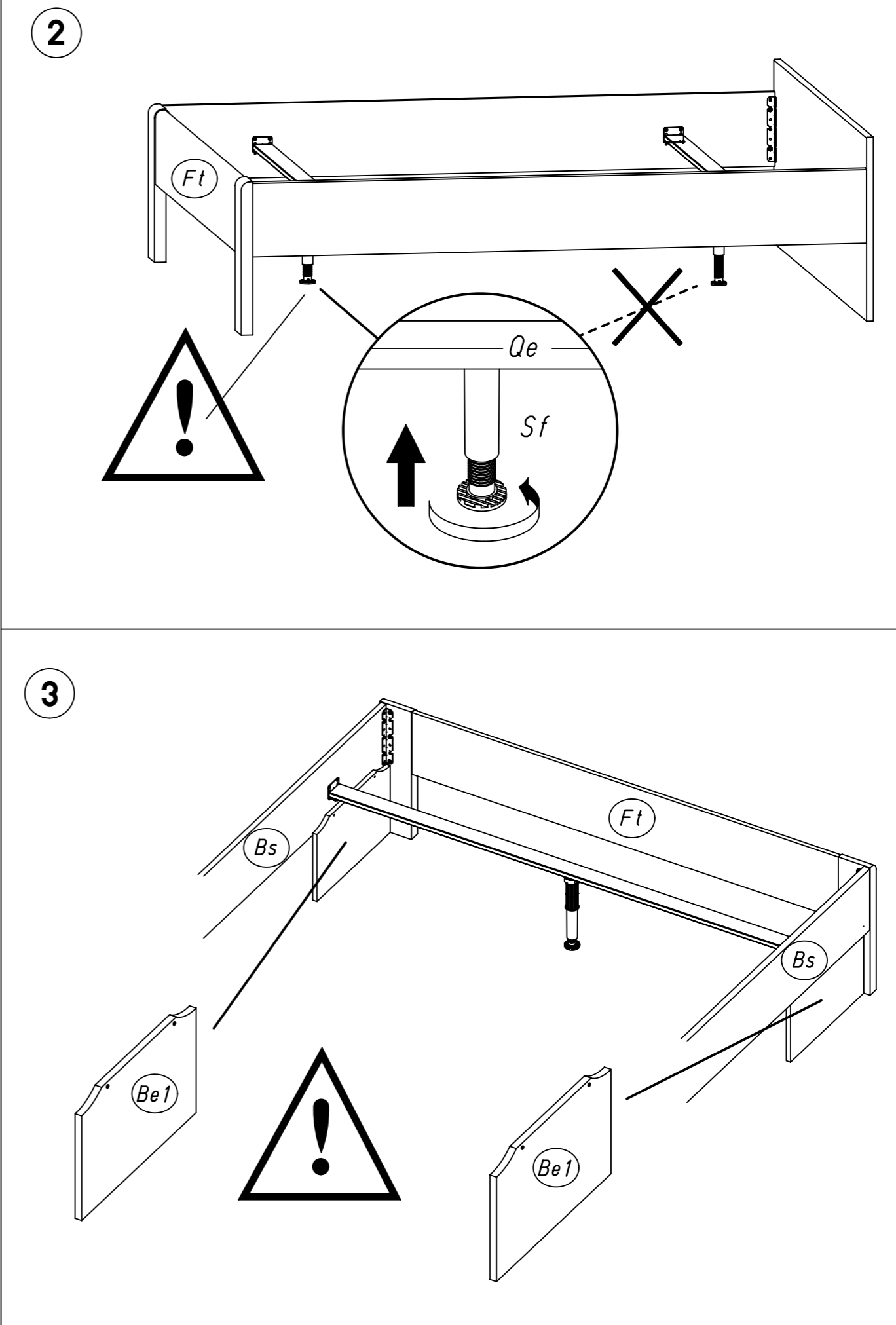
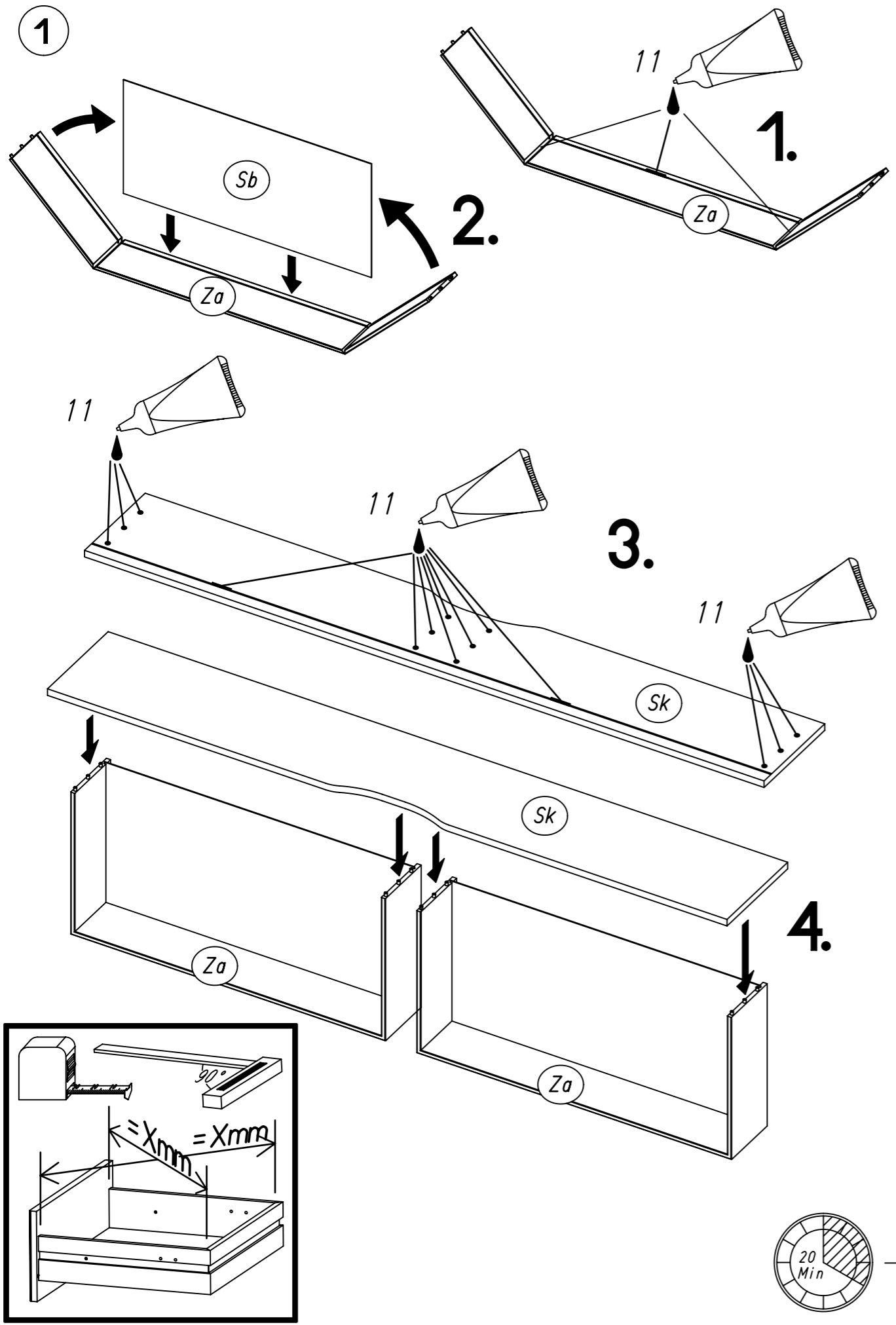



5.

4

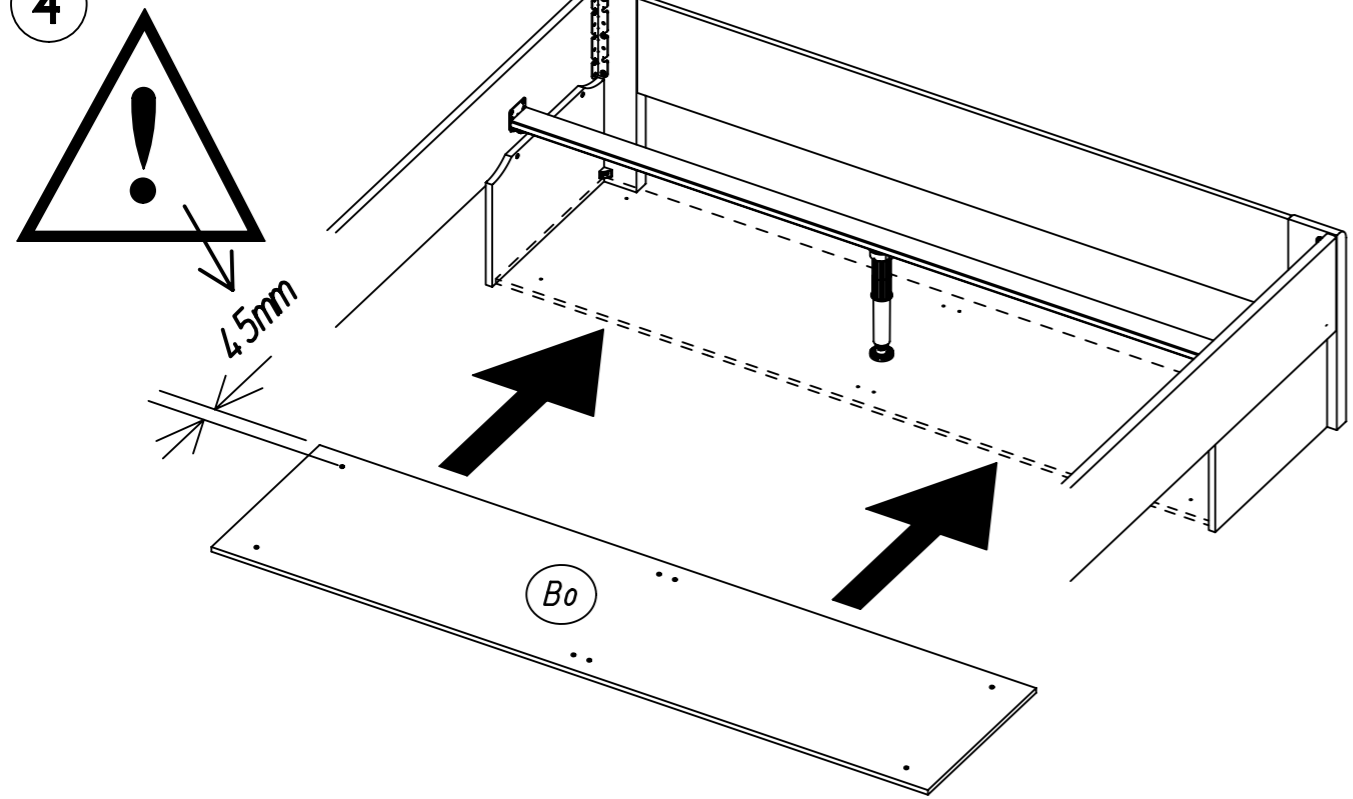

5

458 201

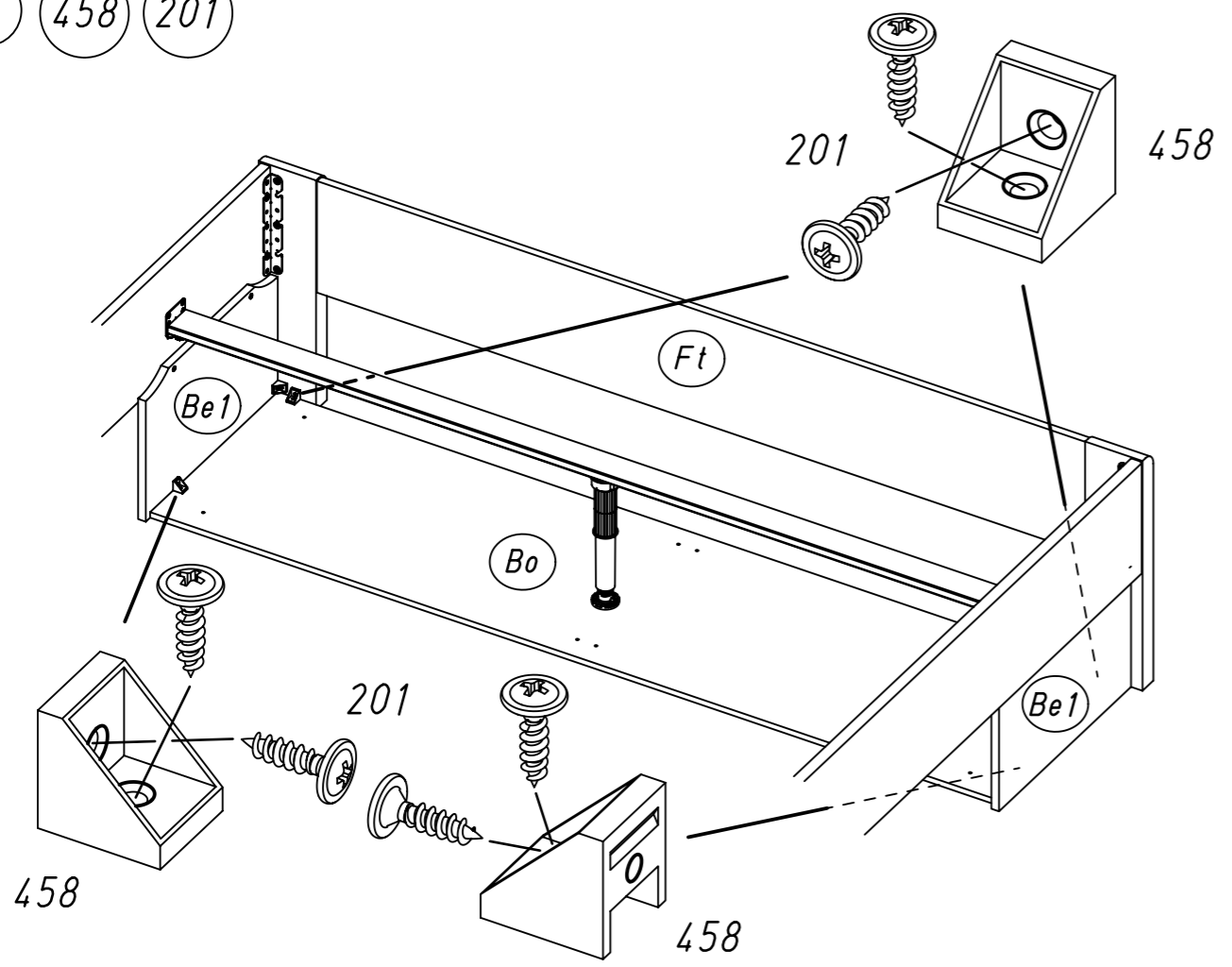

6.

6 227 255 256 94

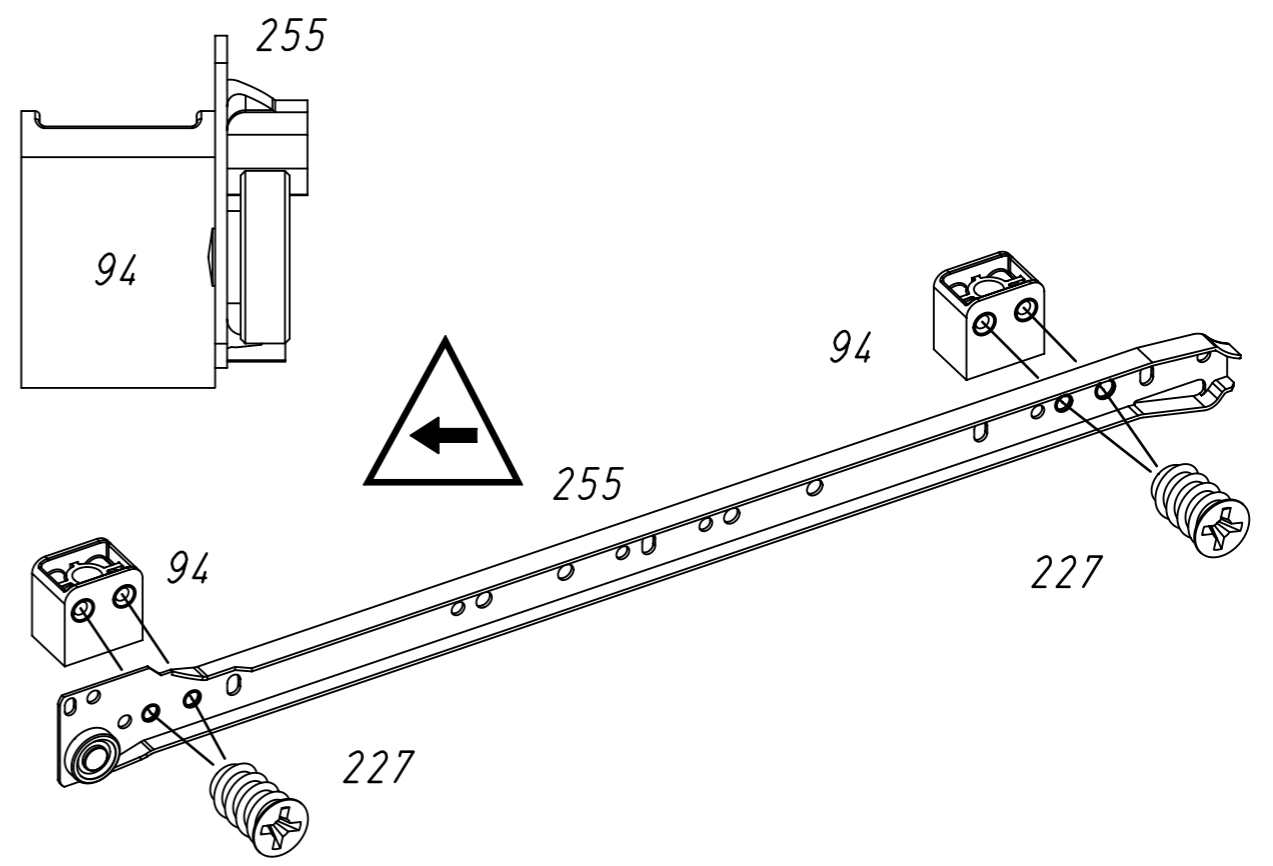
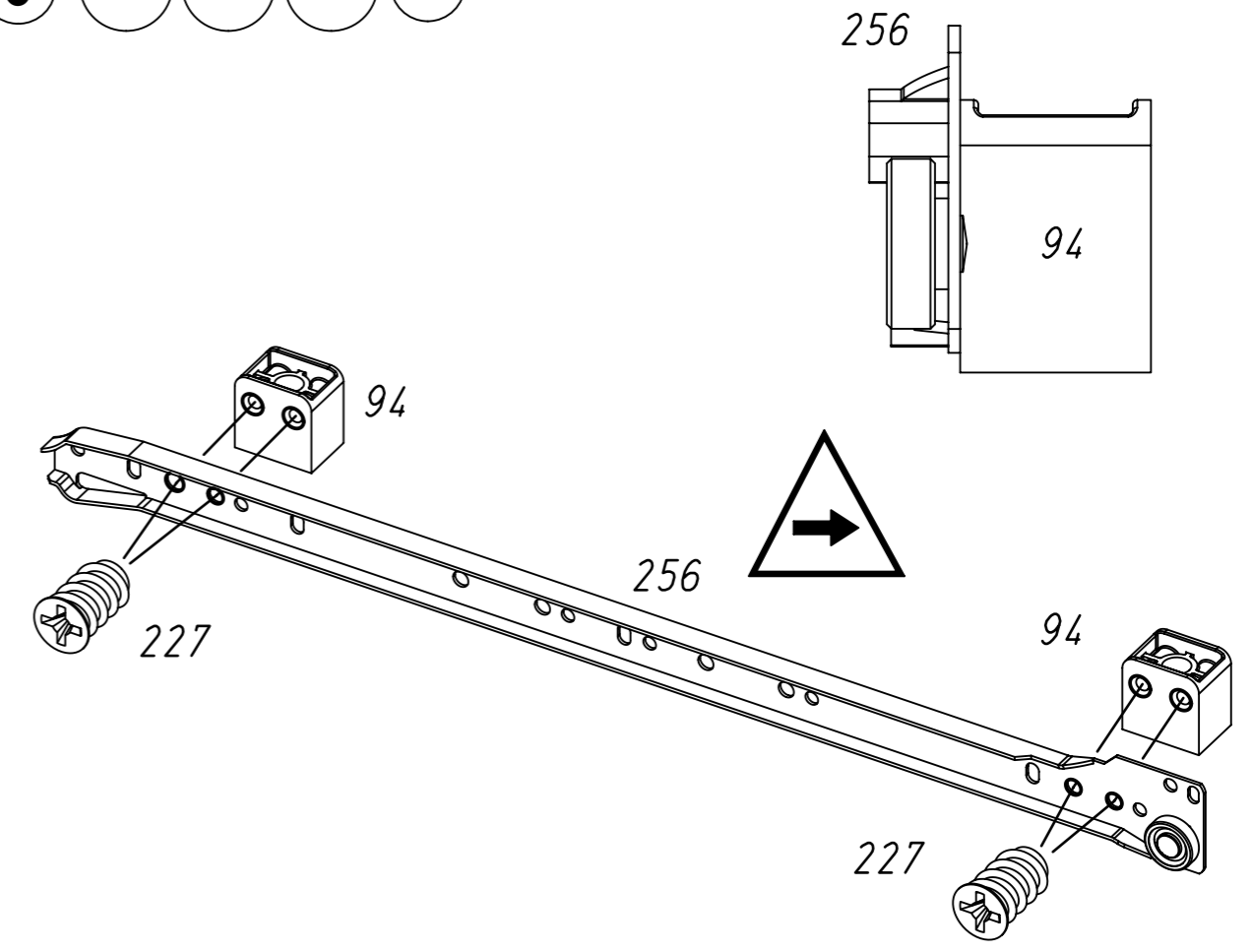

7 242

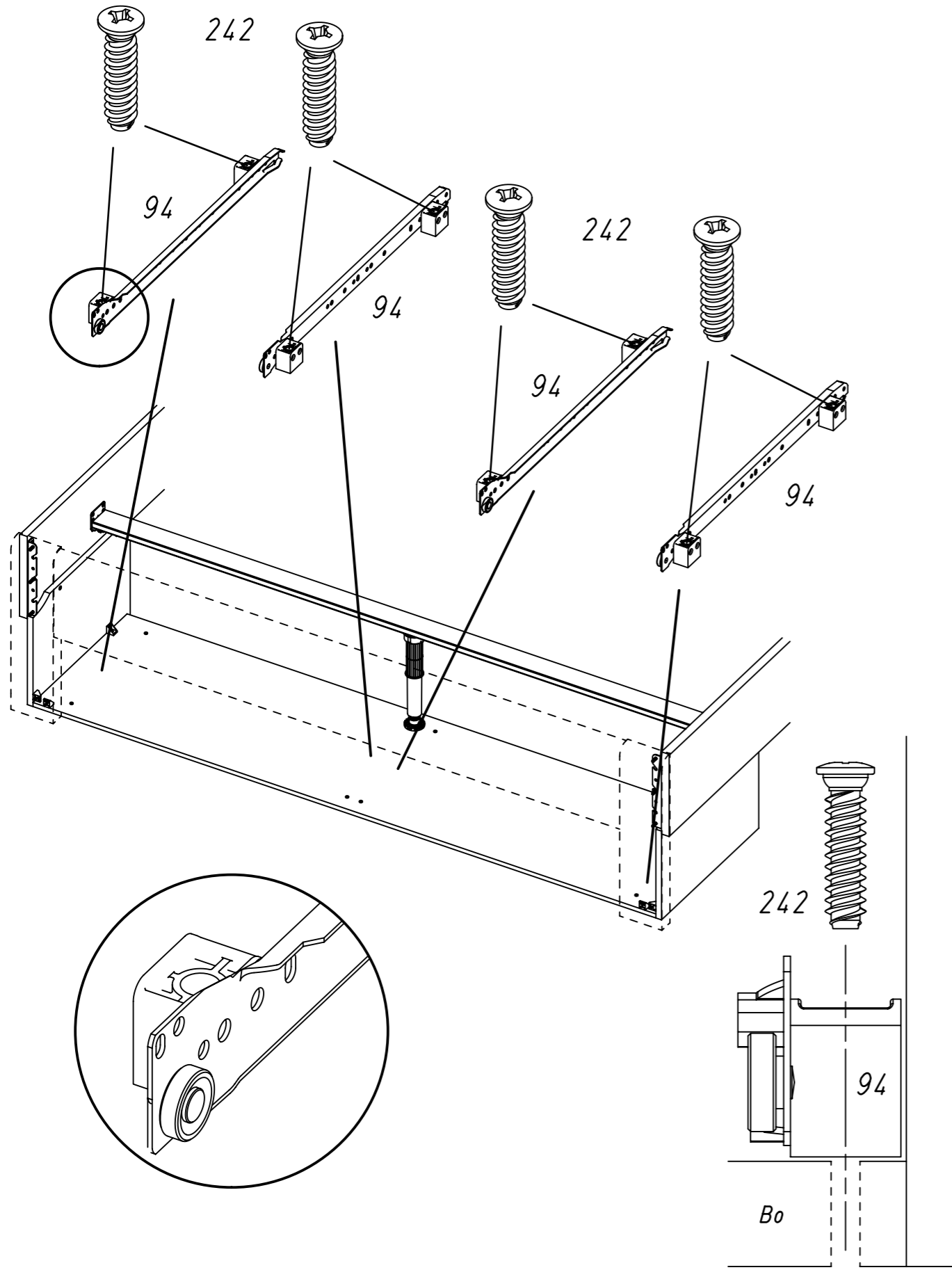

8 208 256 255

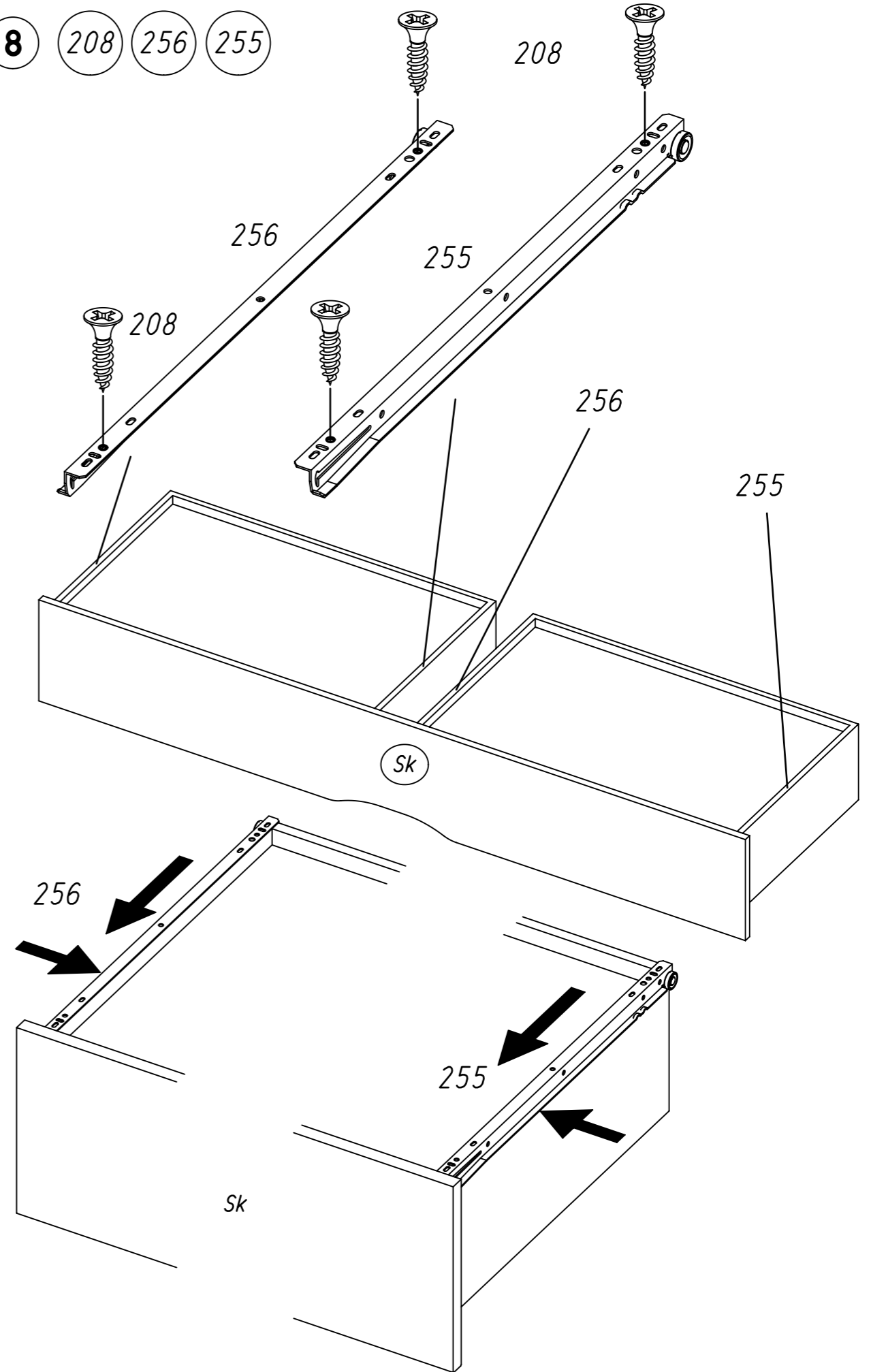

9.

9

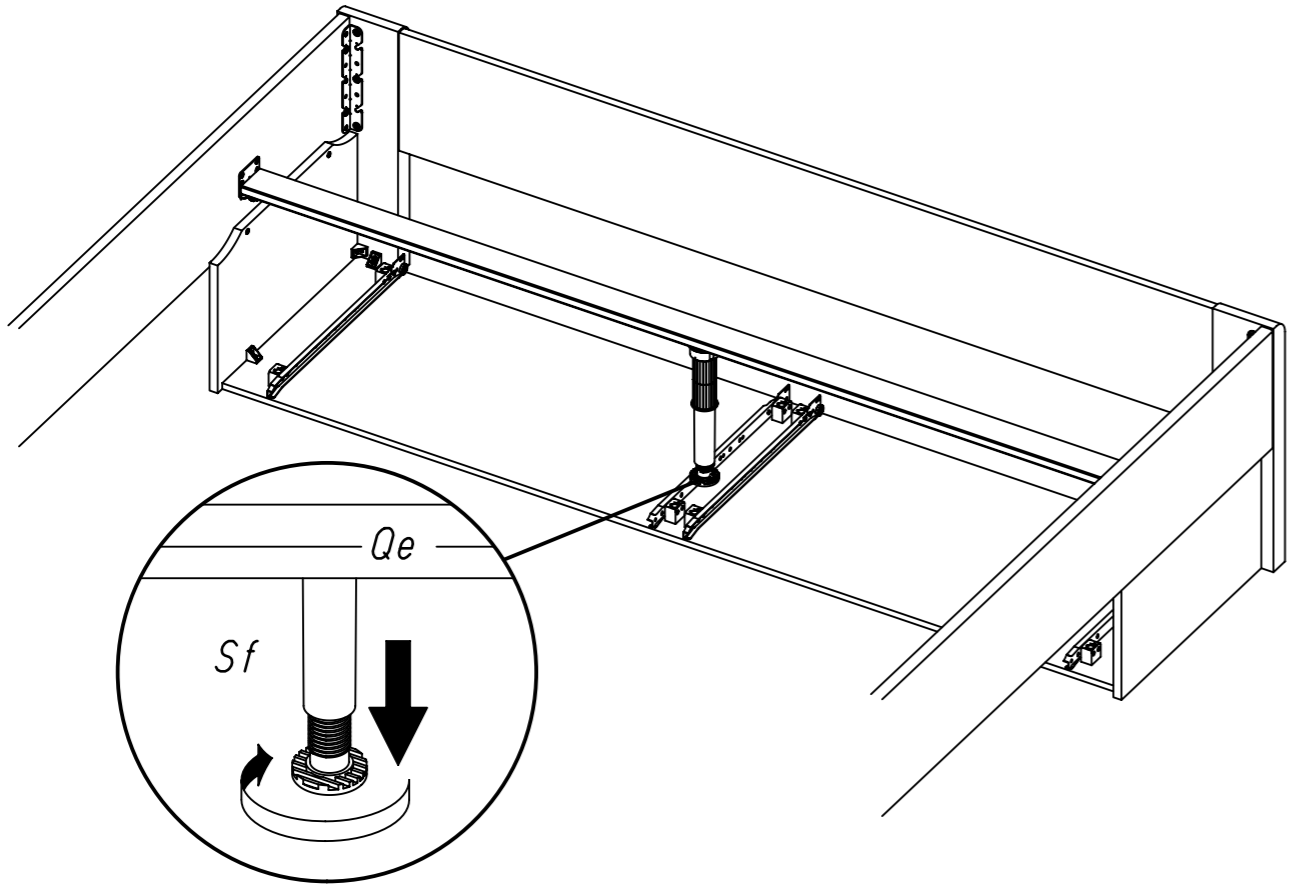

10

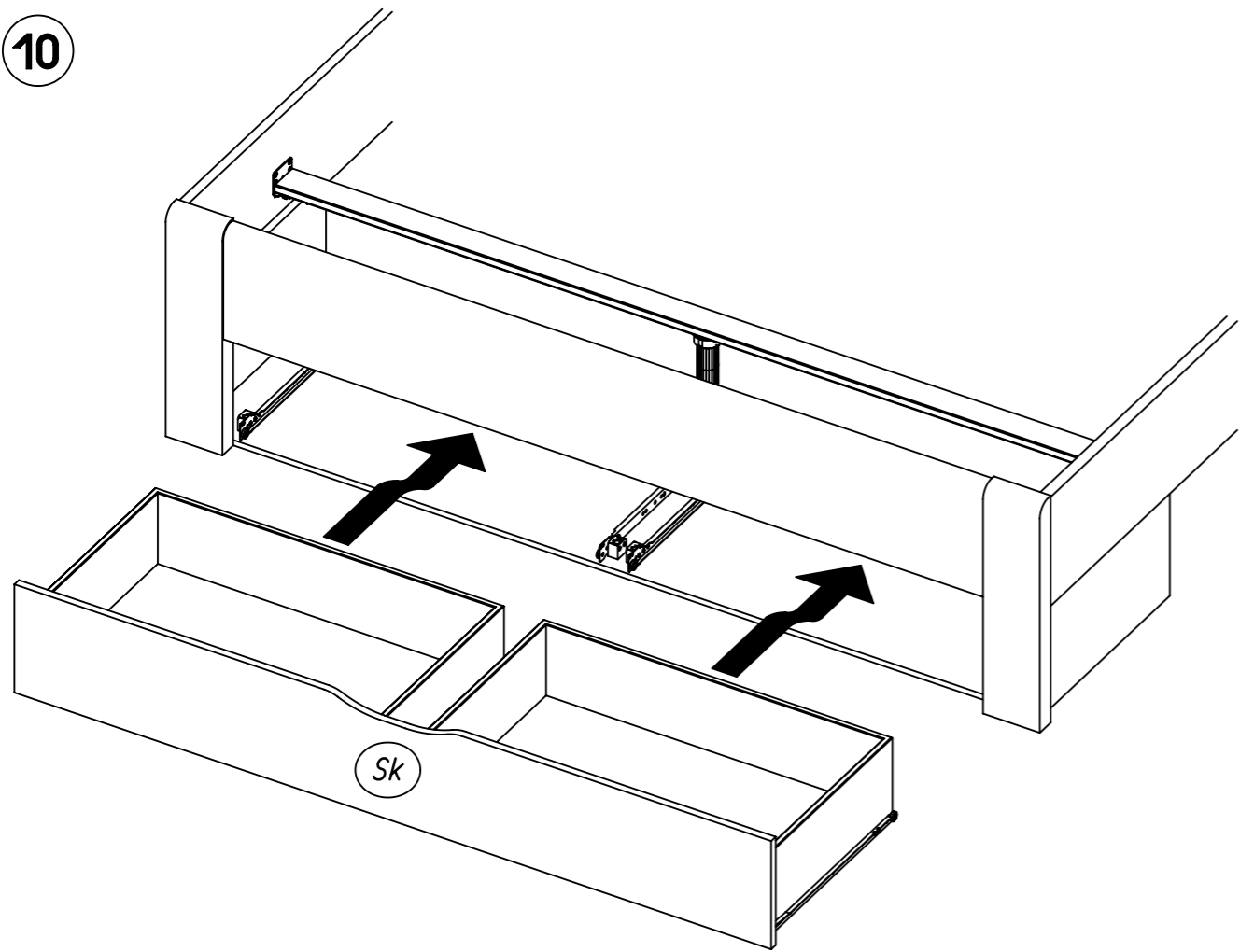

1.

M2061\_02

rauch

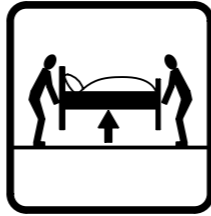
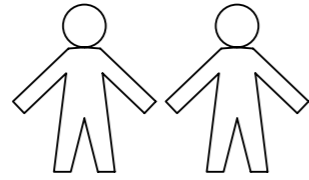
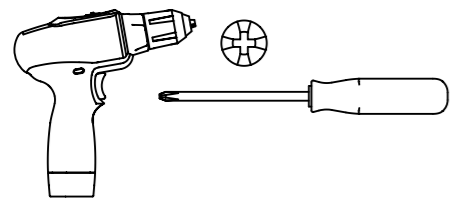

Typ I

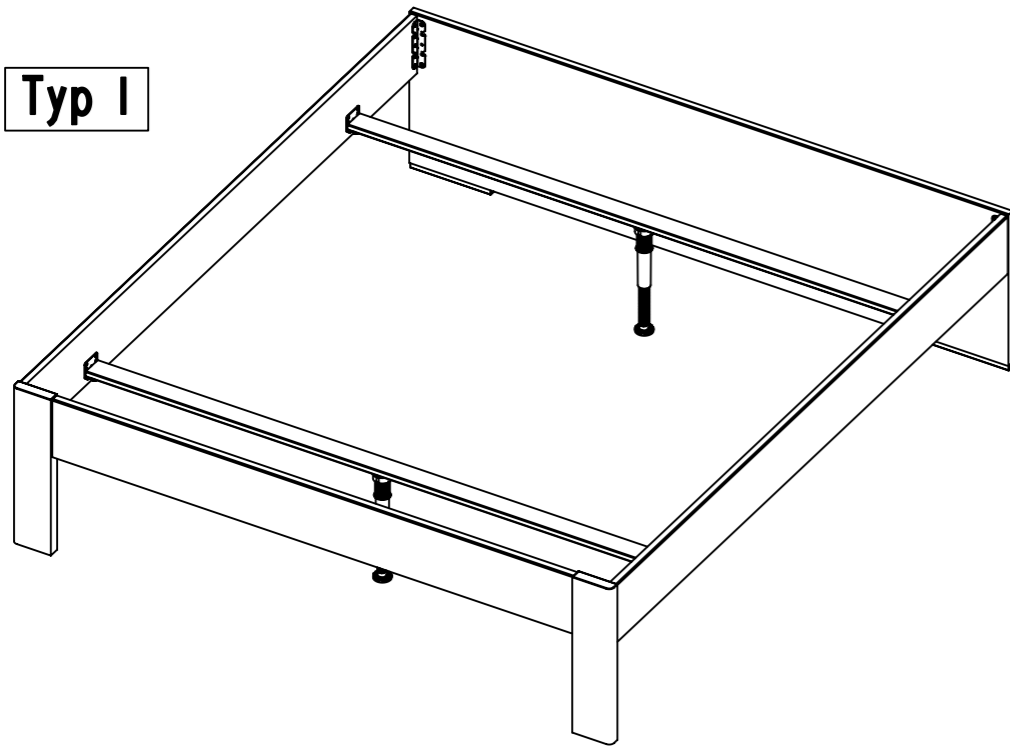

Typ II

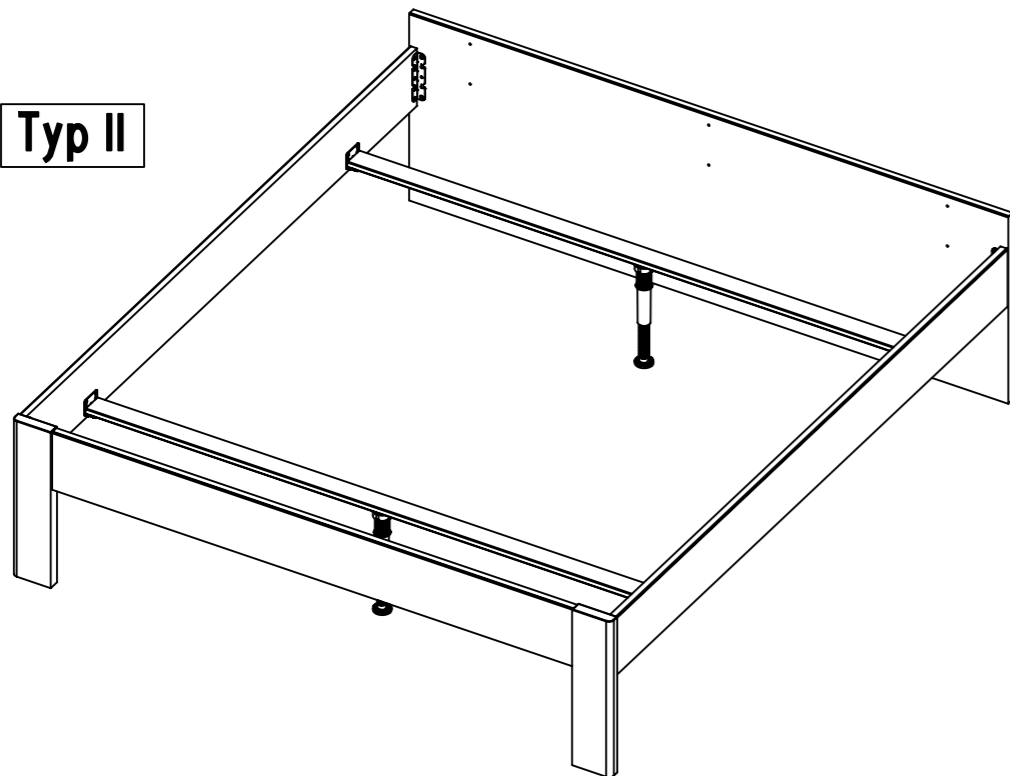

2.

Typ I

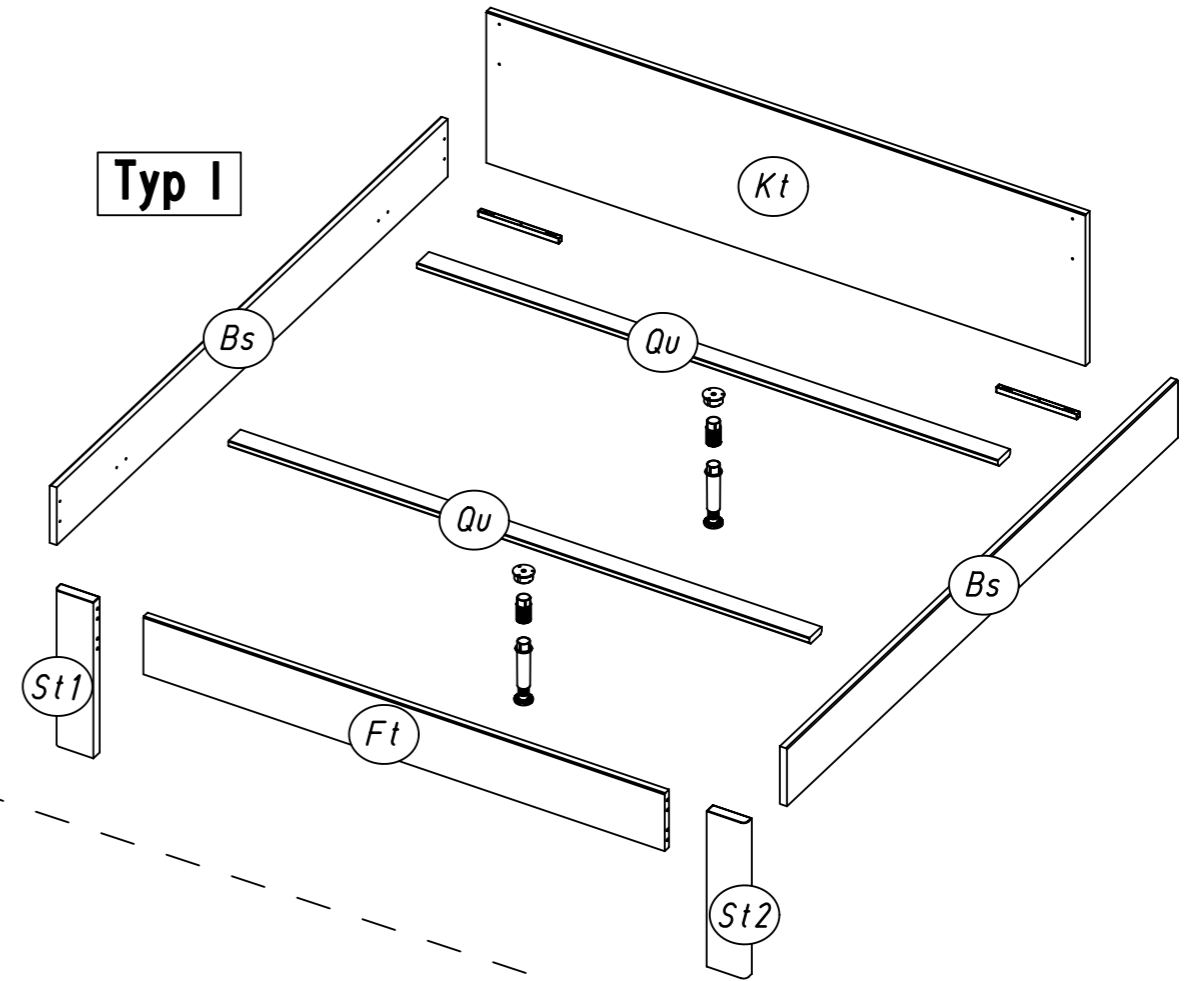

Typ II

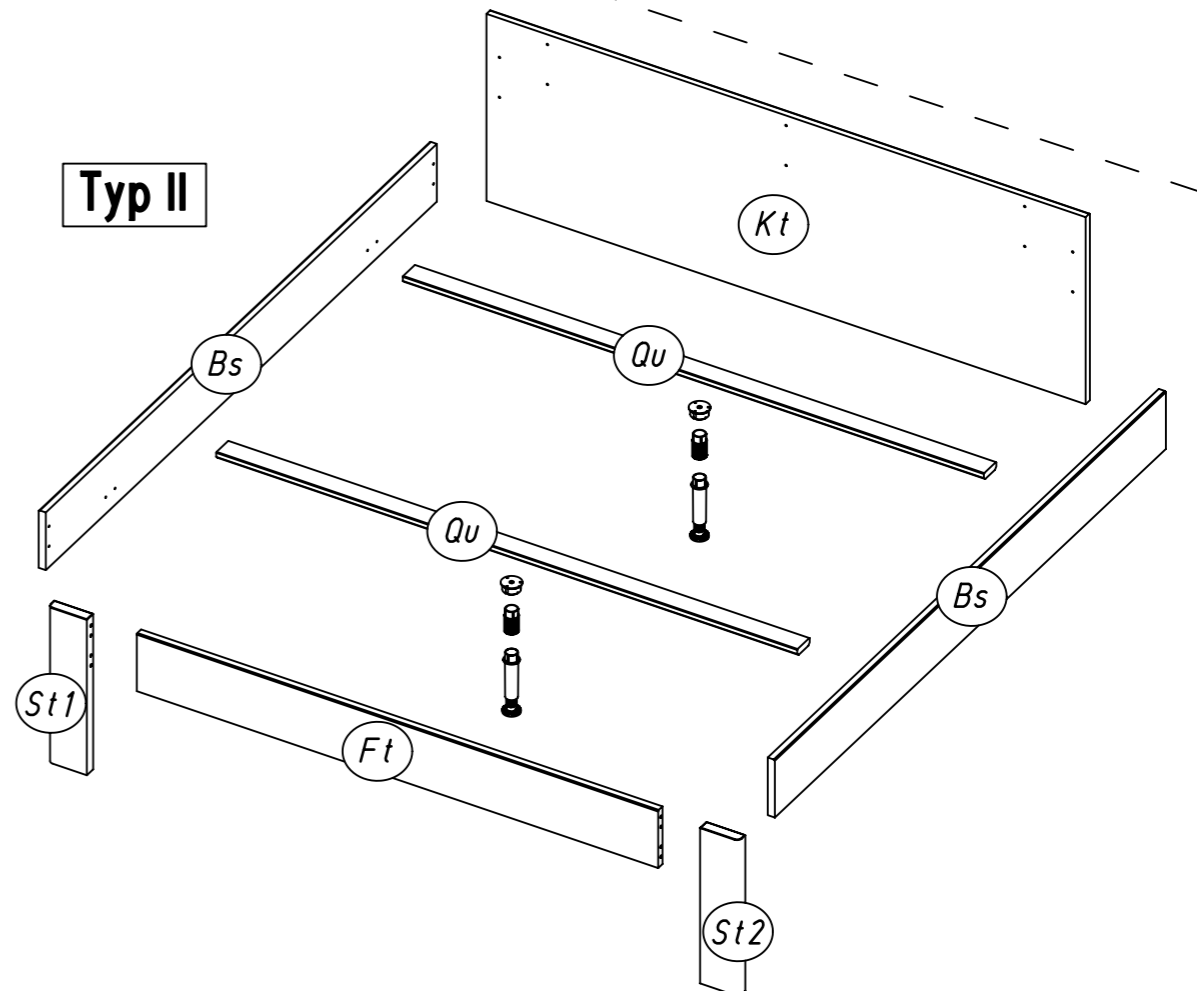

3.

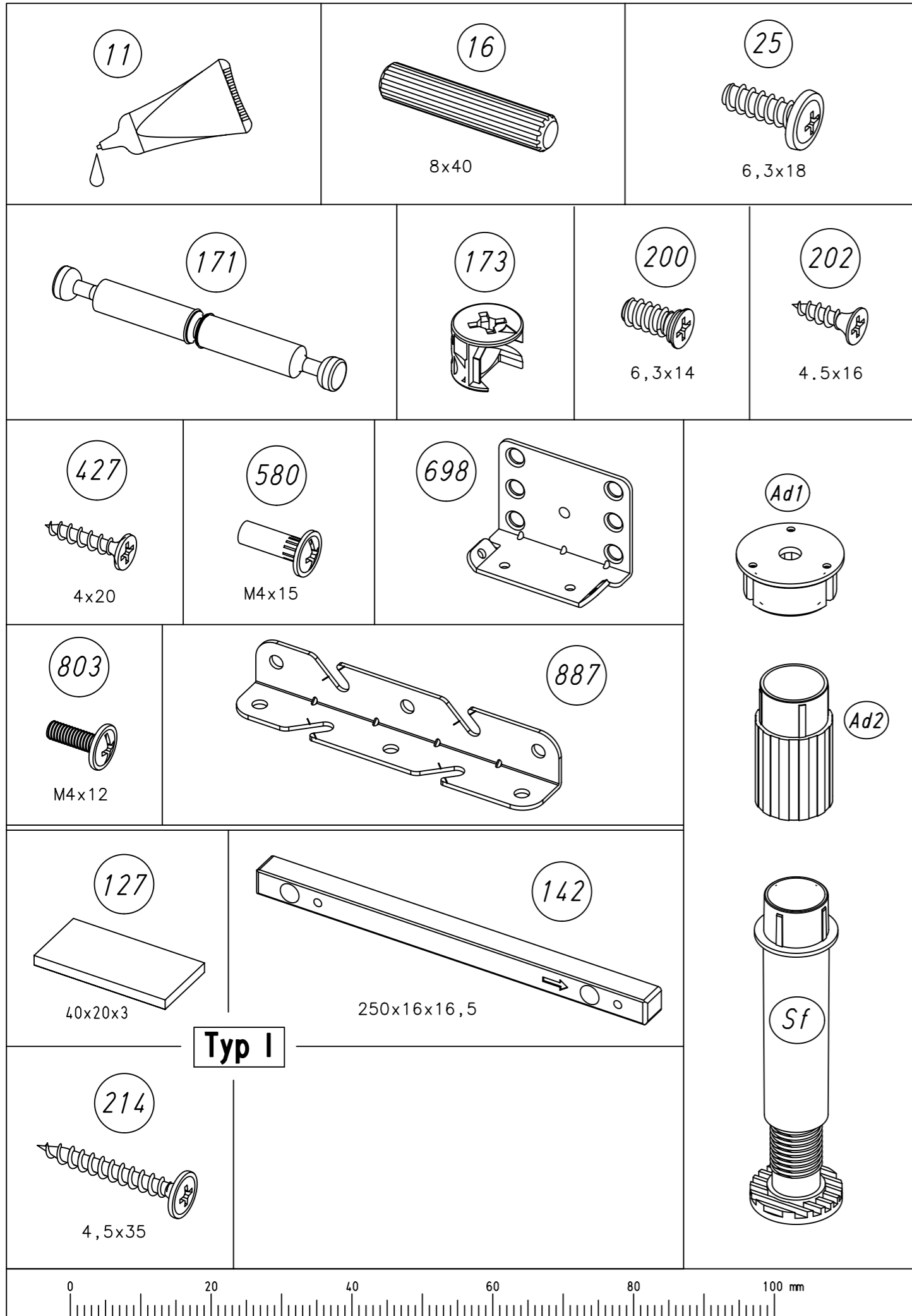

M2061

4.

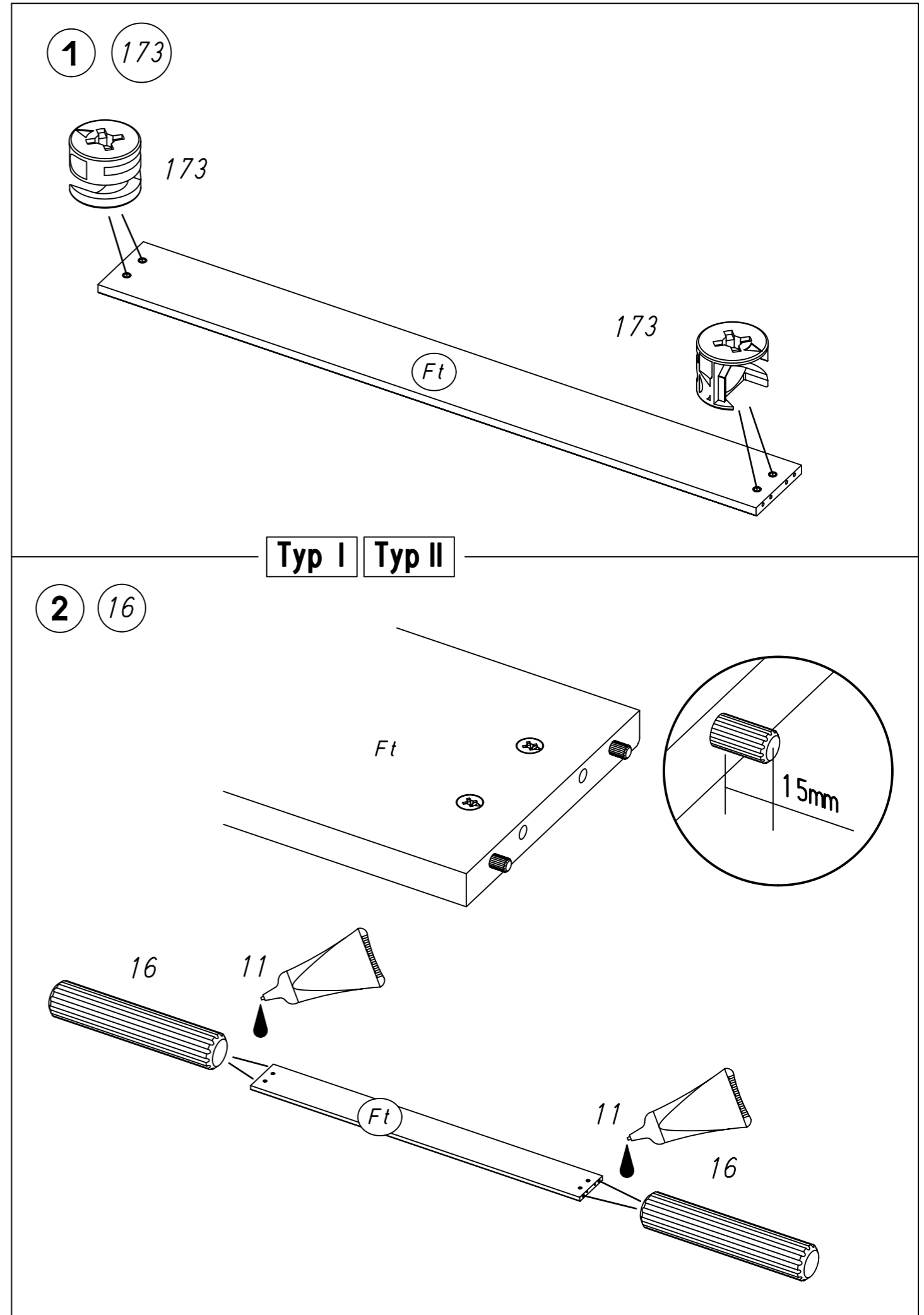

M2061

5.

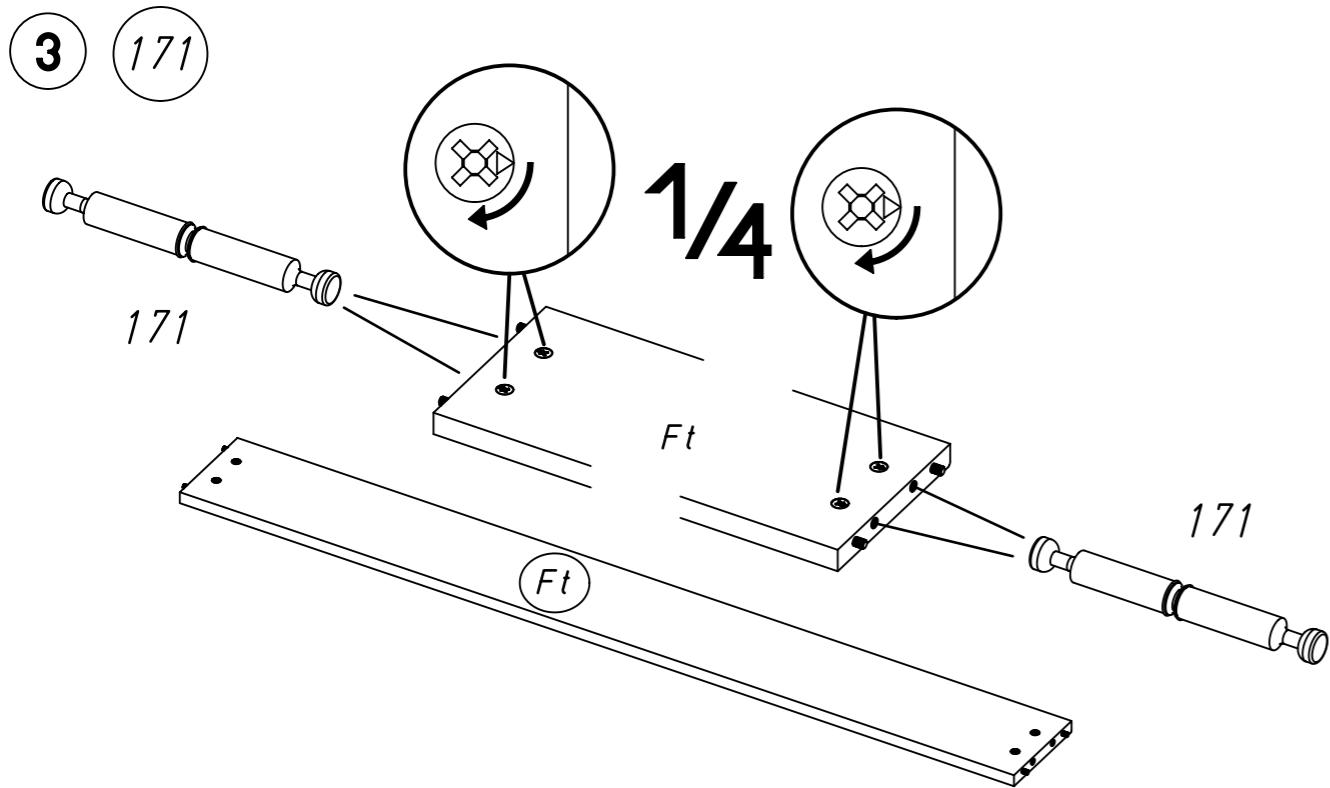

Typ I Typ II

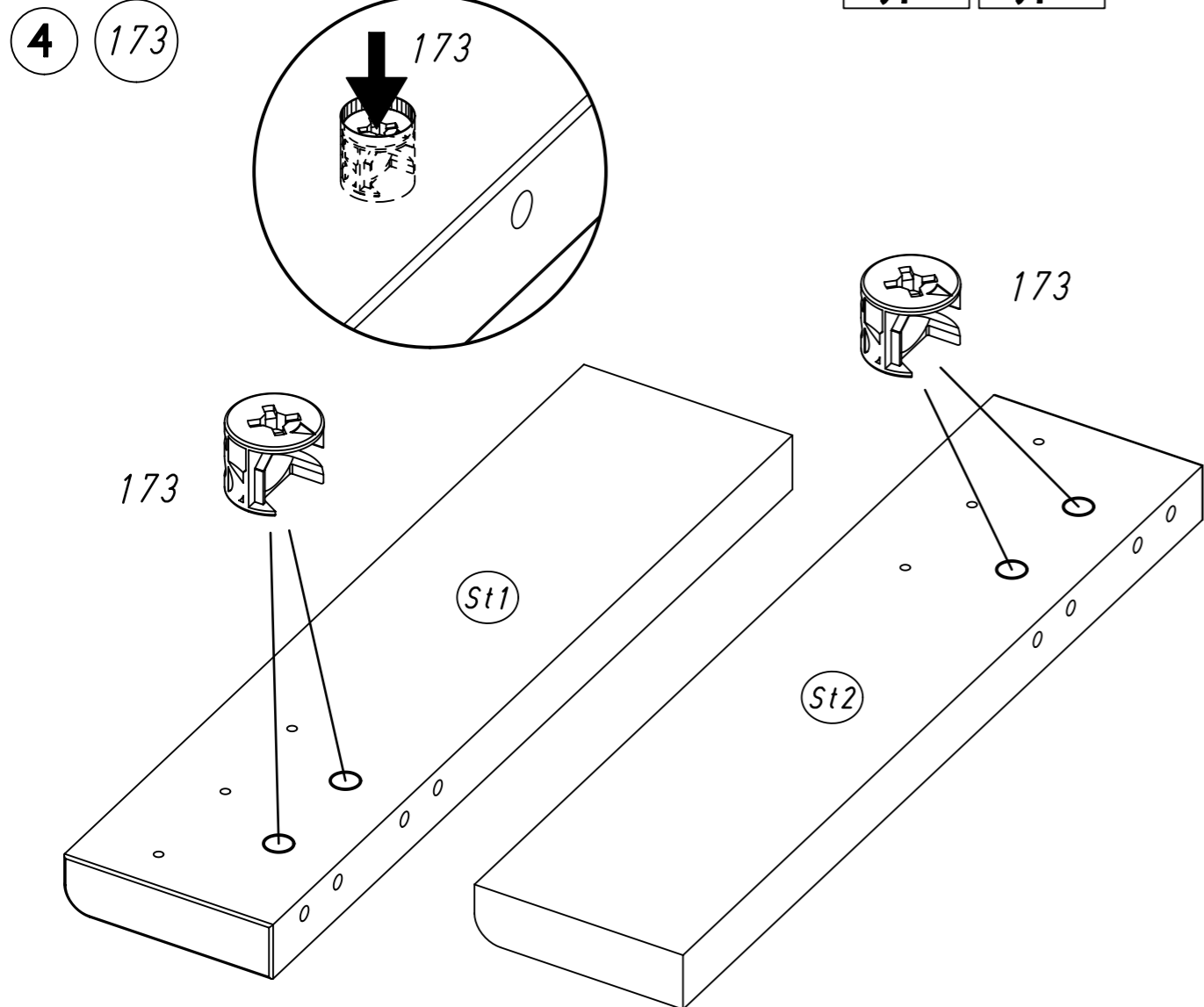

6.

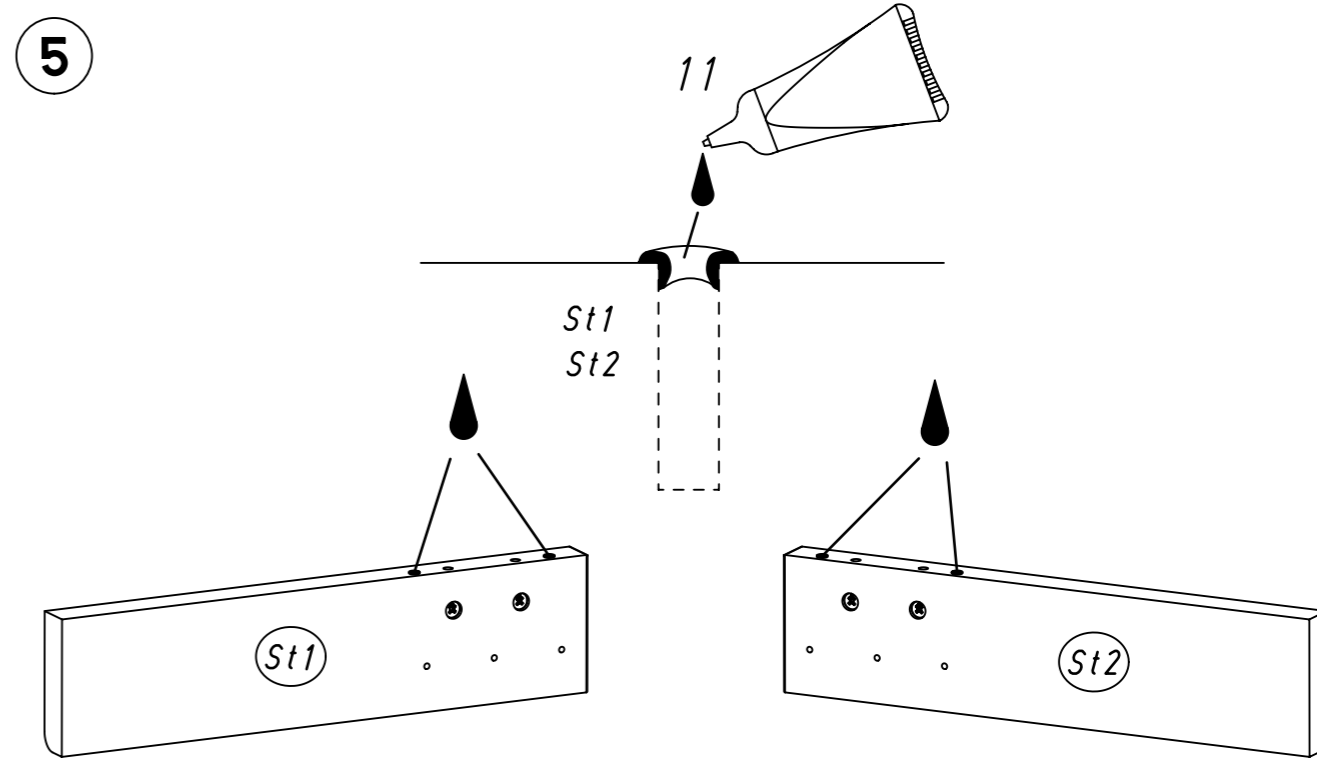

Typ I Typ II

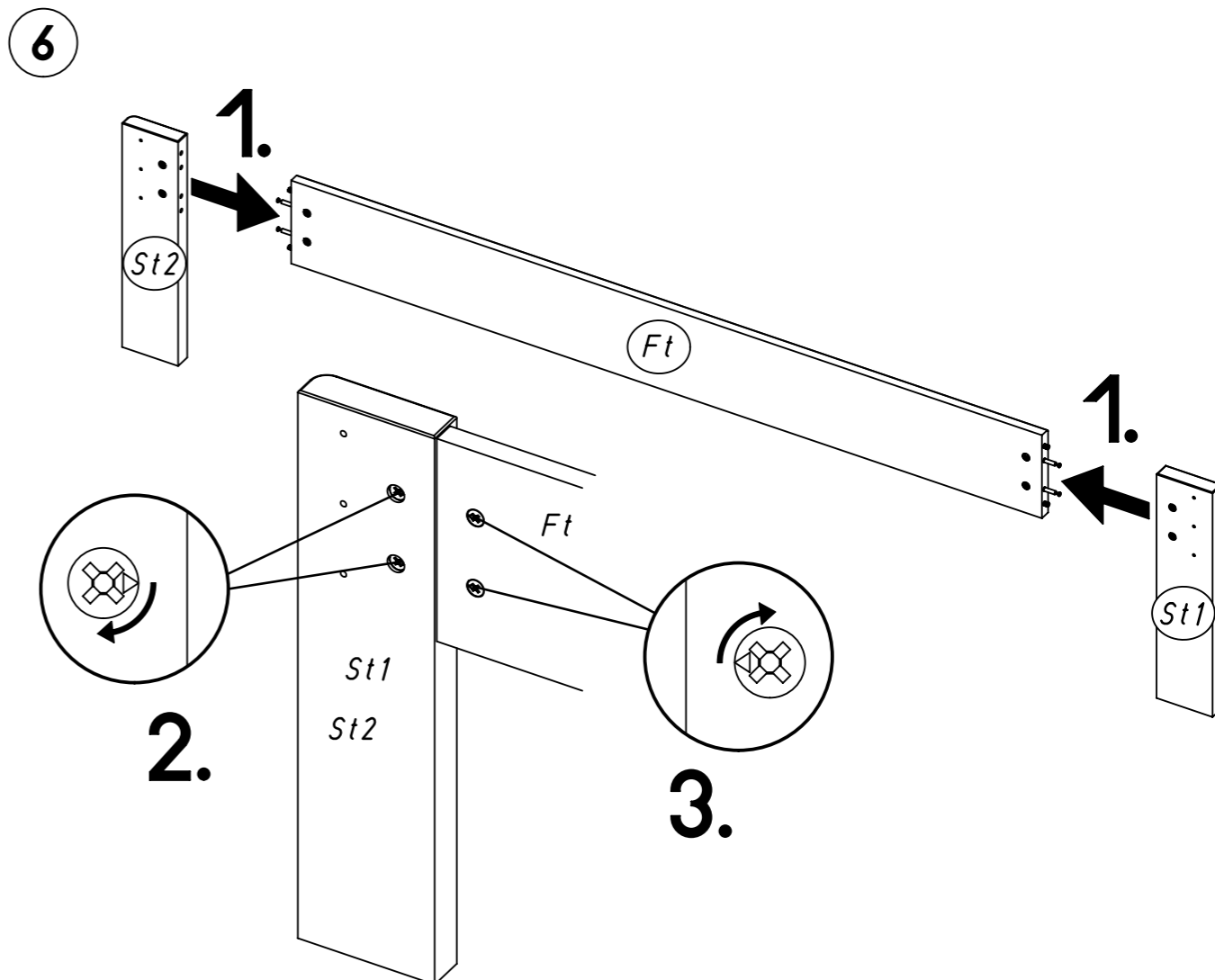

7 25 887

Typ I Typ II

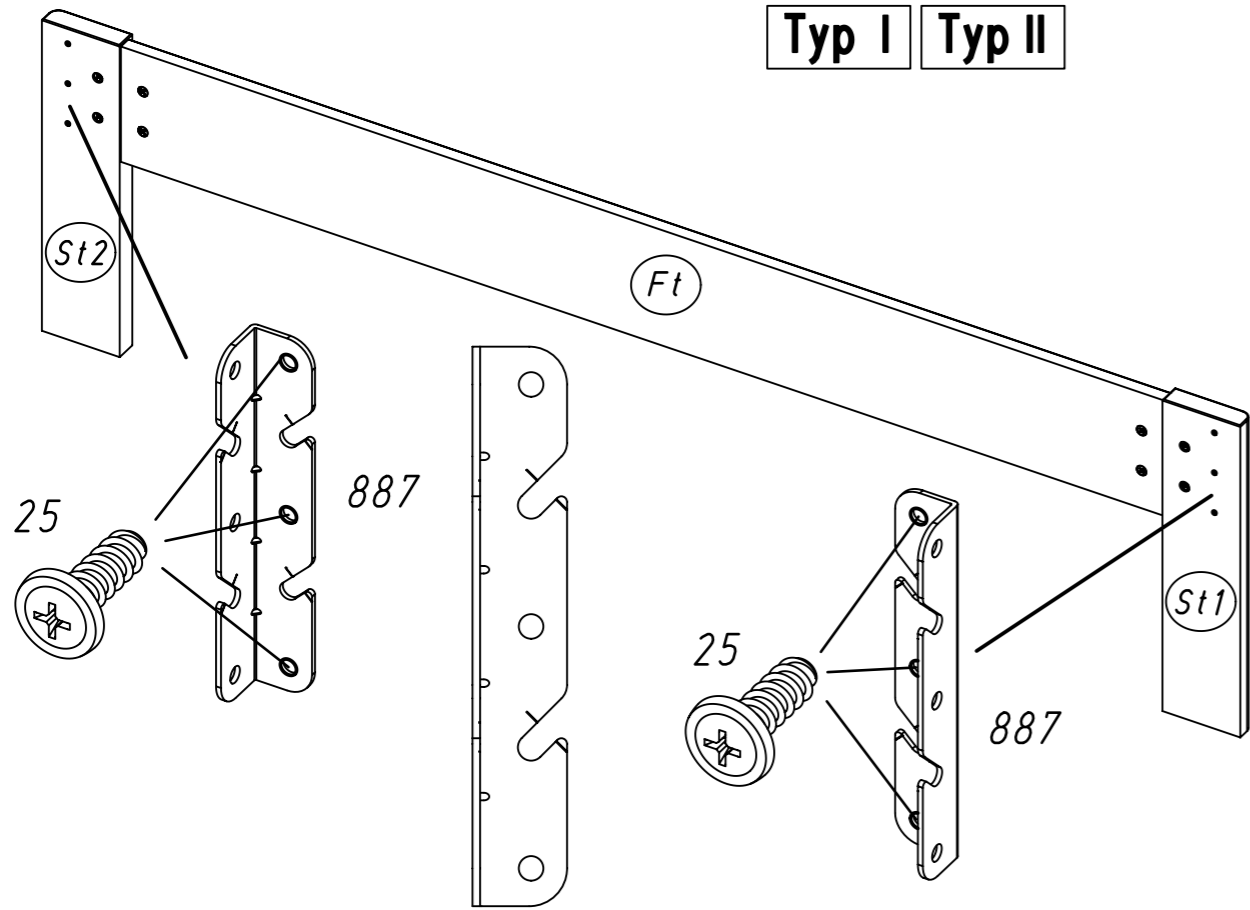

9 580 803 887

Typ I Typ II

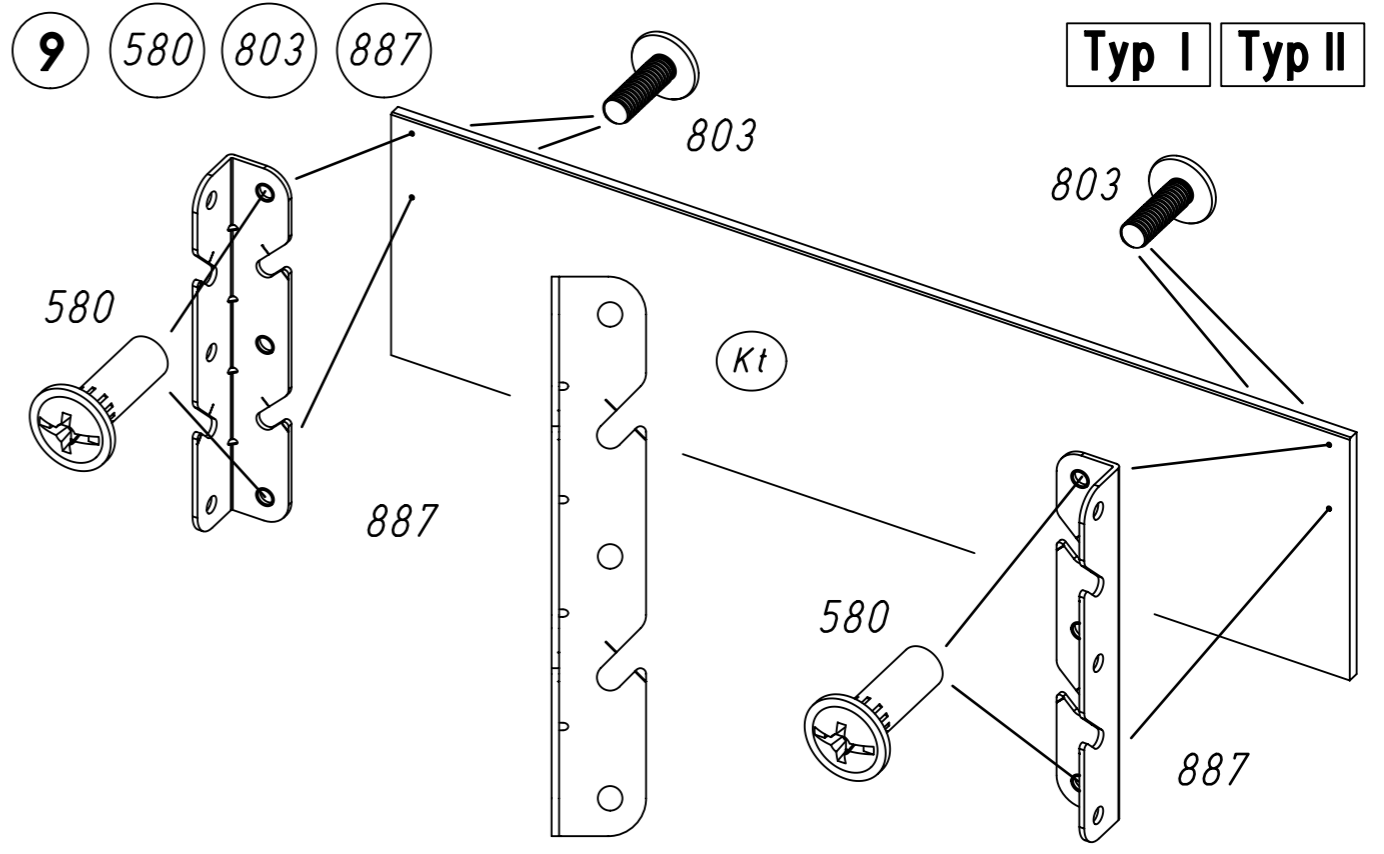

8 127

Typ I

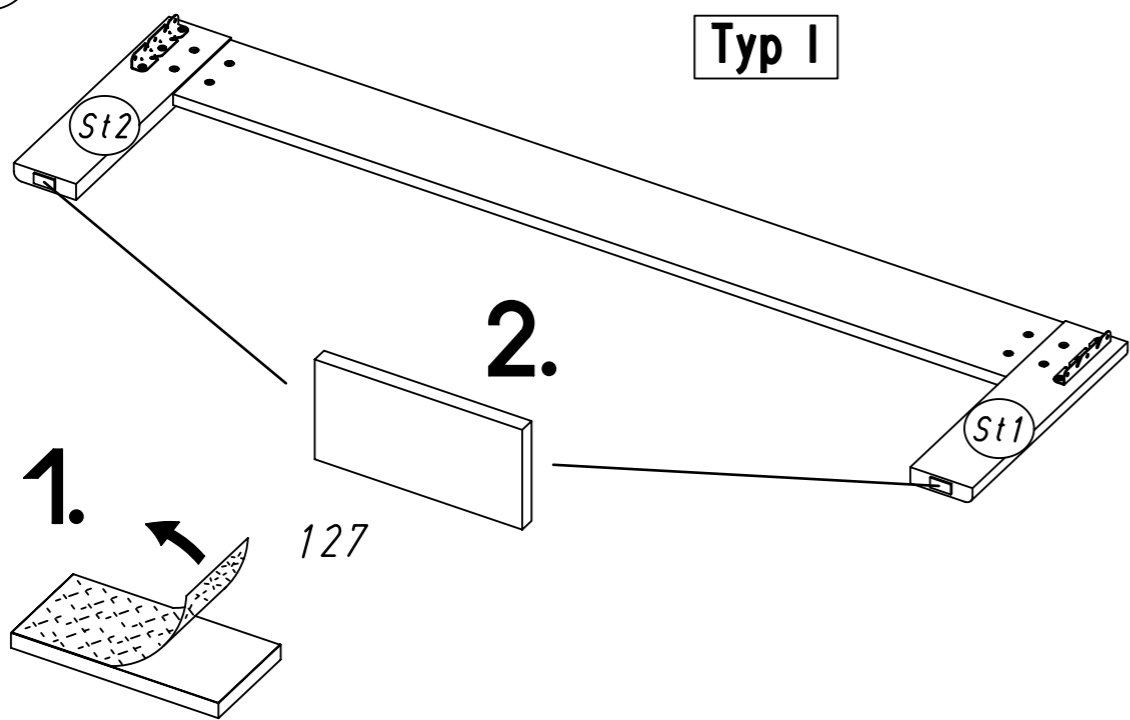

10 142 214

Typ I

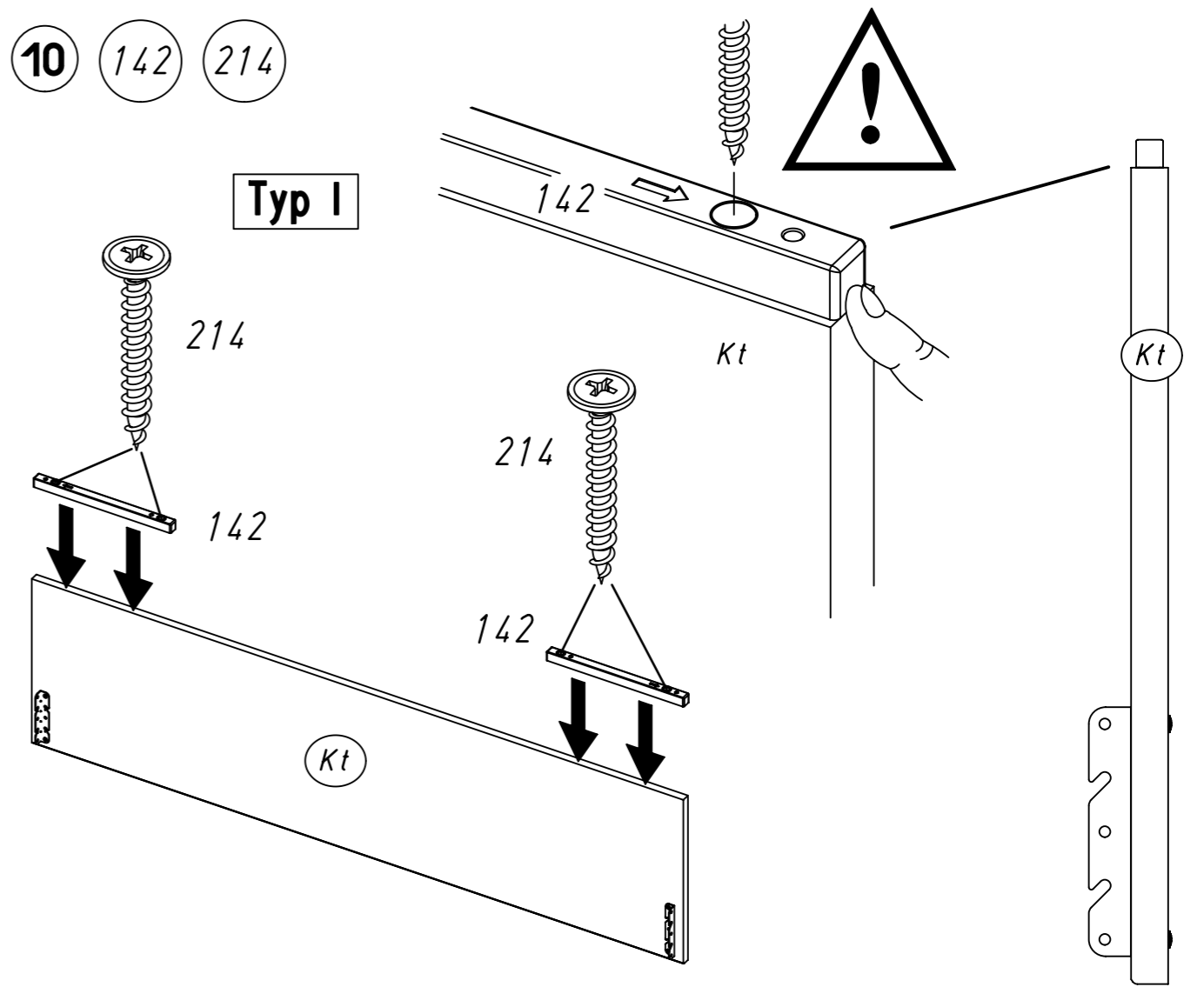

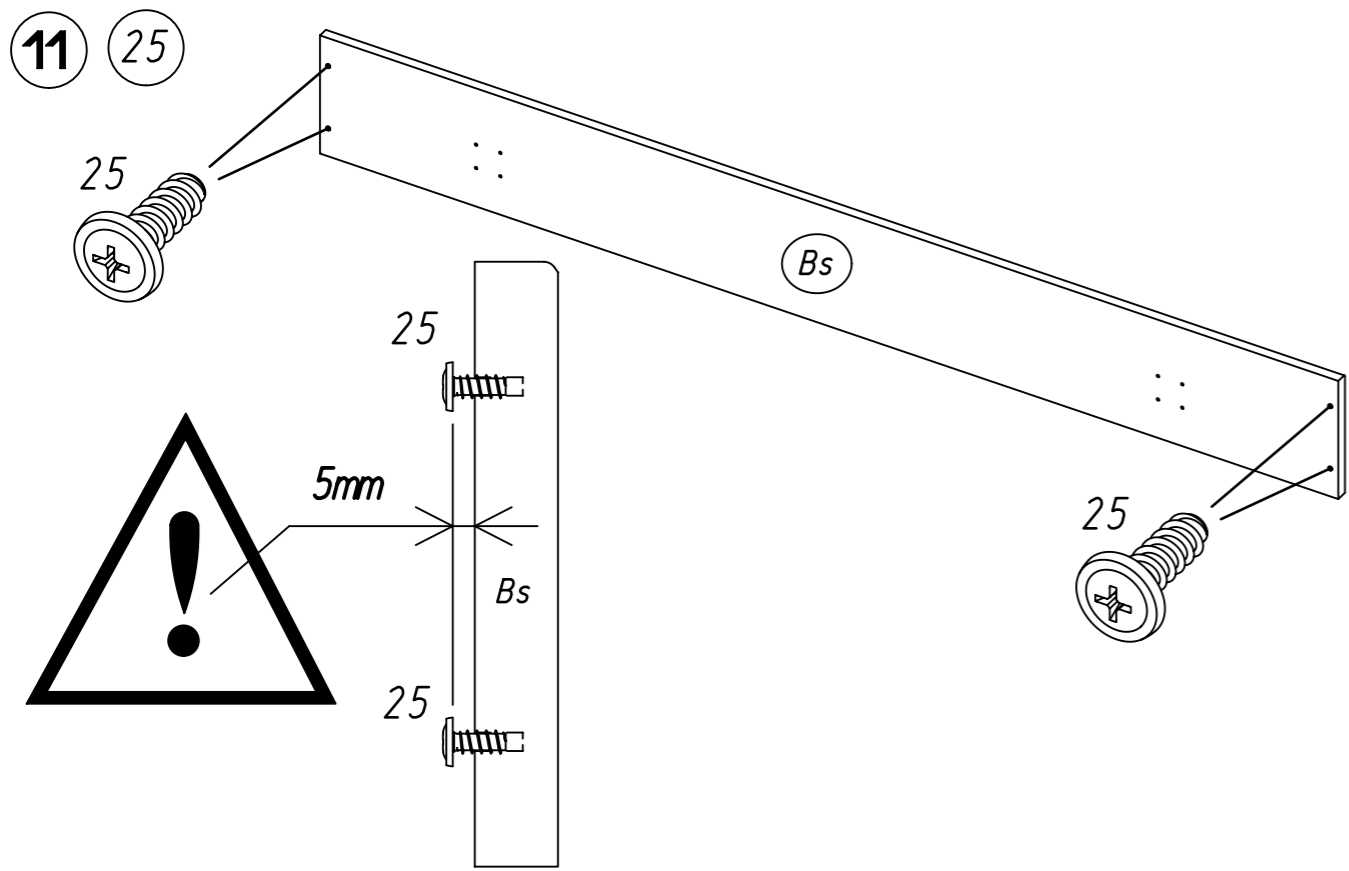

Typ I Typ II

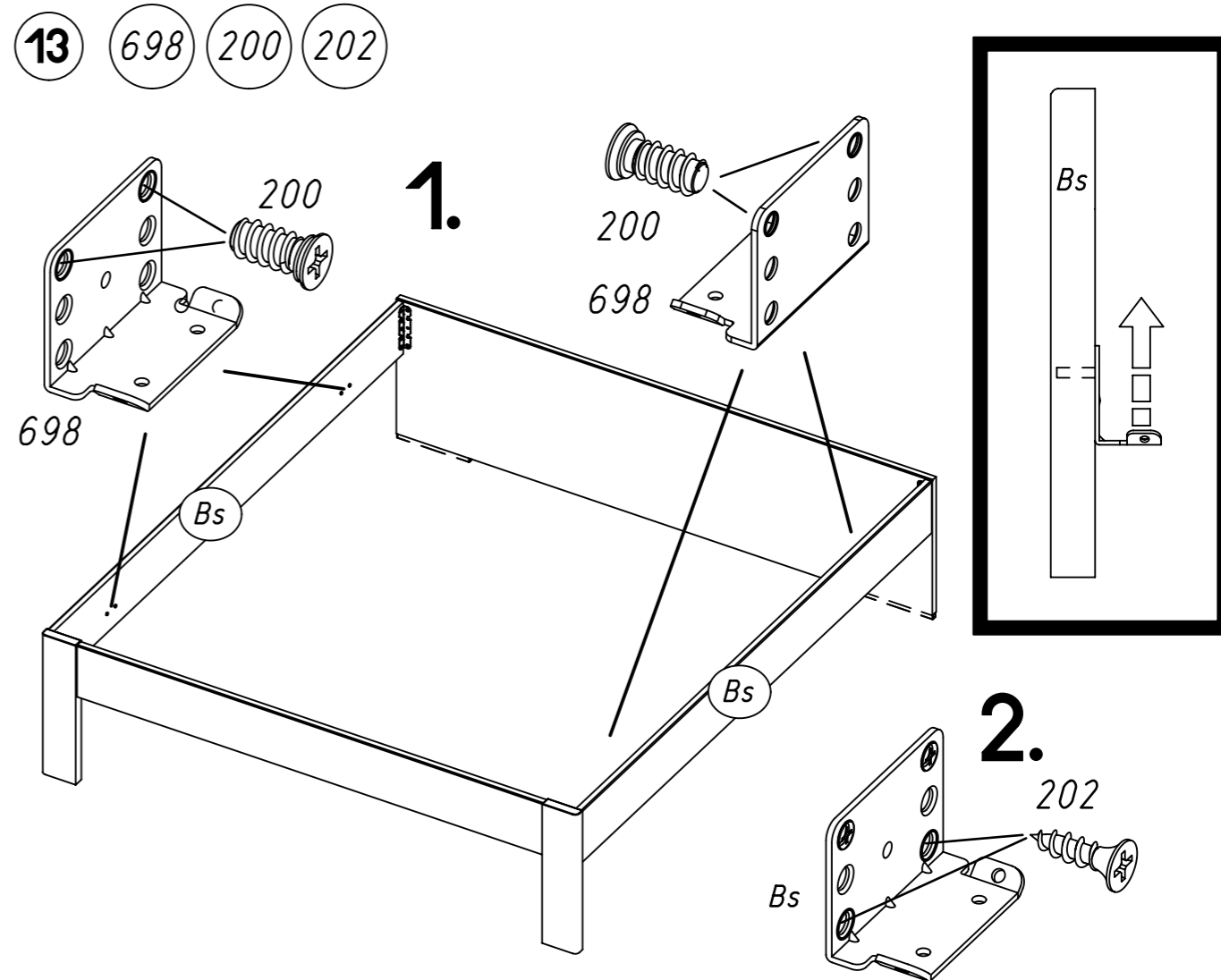
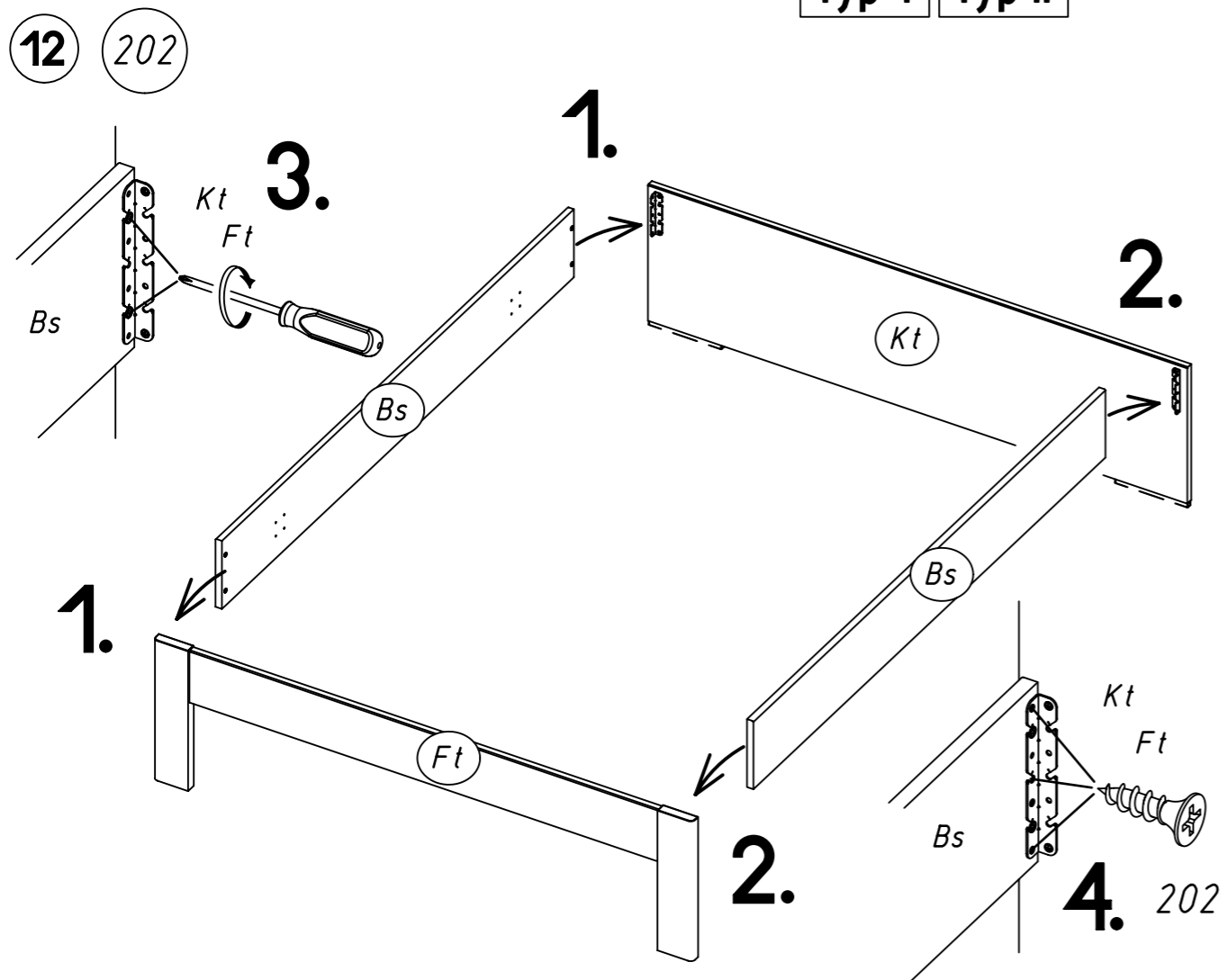

Typ I Typ II

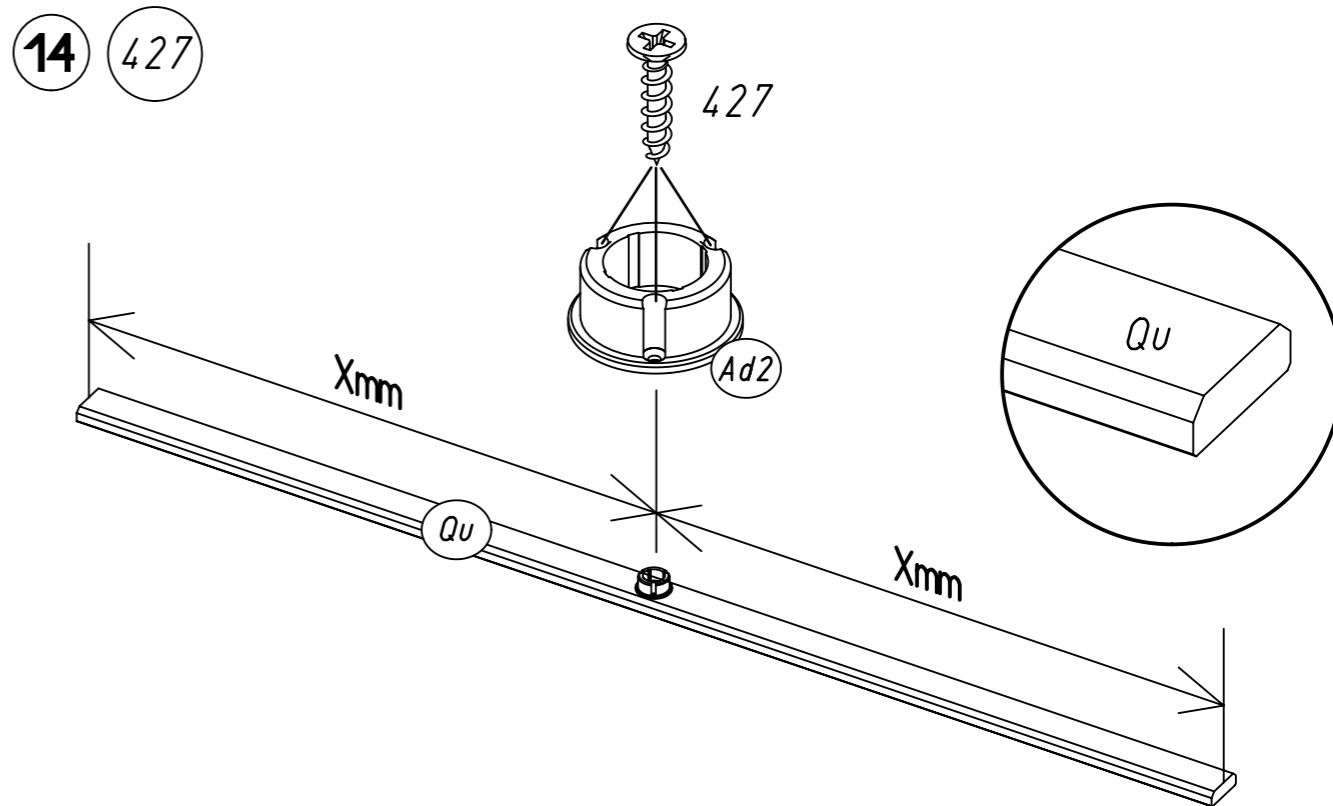



15 202

Typ I Typ II

