

1 → 2 → 3 ...

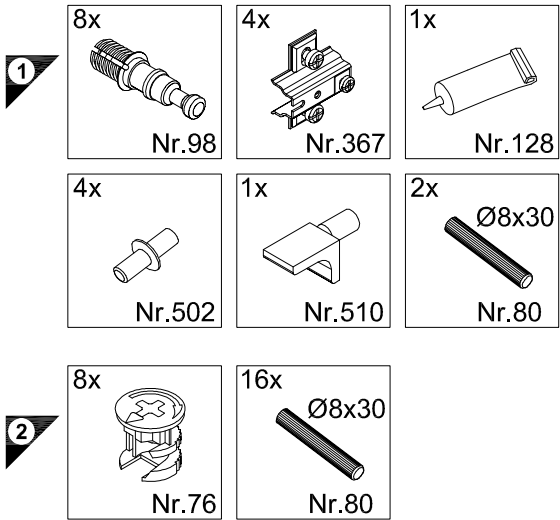

**Service-Hotline**  
01805-678101  
0,14€ pro Minute  
**++49 für Österreich**  
Auslandstarif pro Minute  
**service@jaka-bkl.de**  
voor Nederland en België  
**00800-40119350**  
**benelux@jaka-bkl.de**

# Montageanleitung

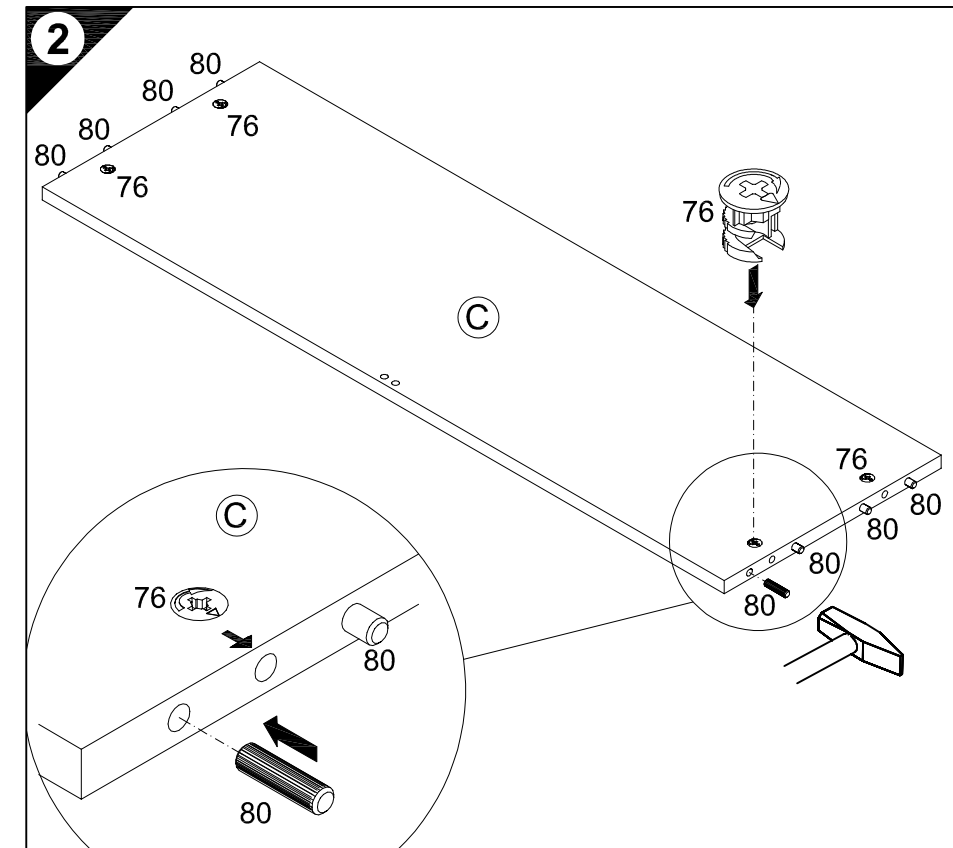
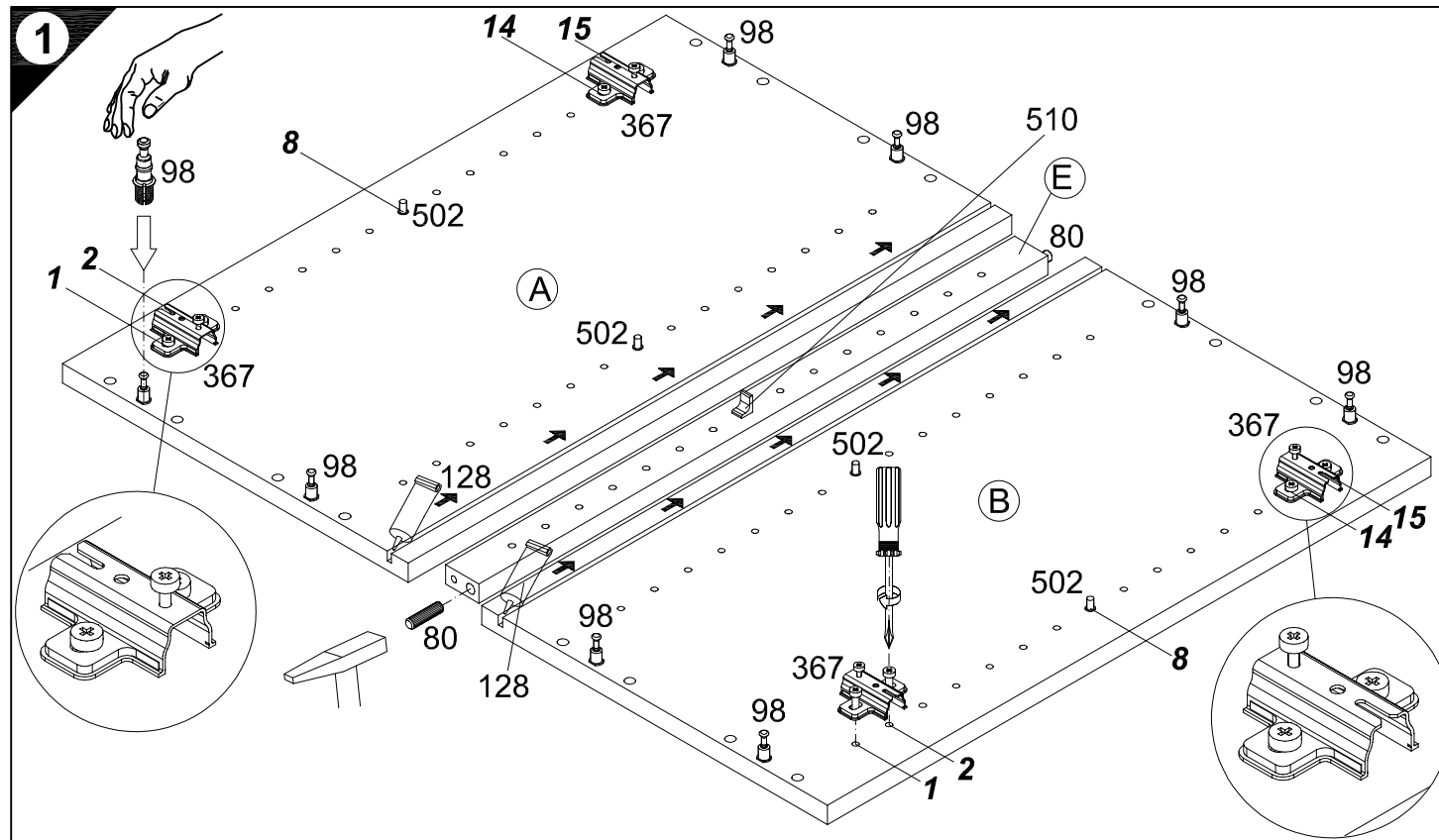
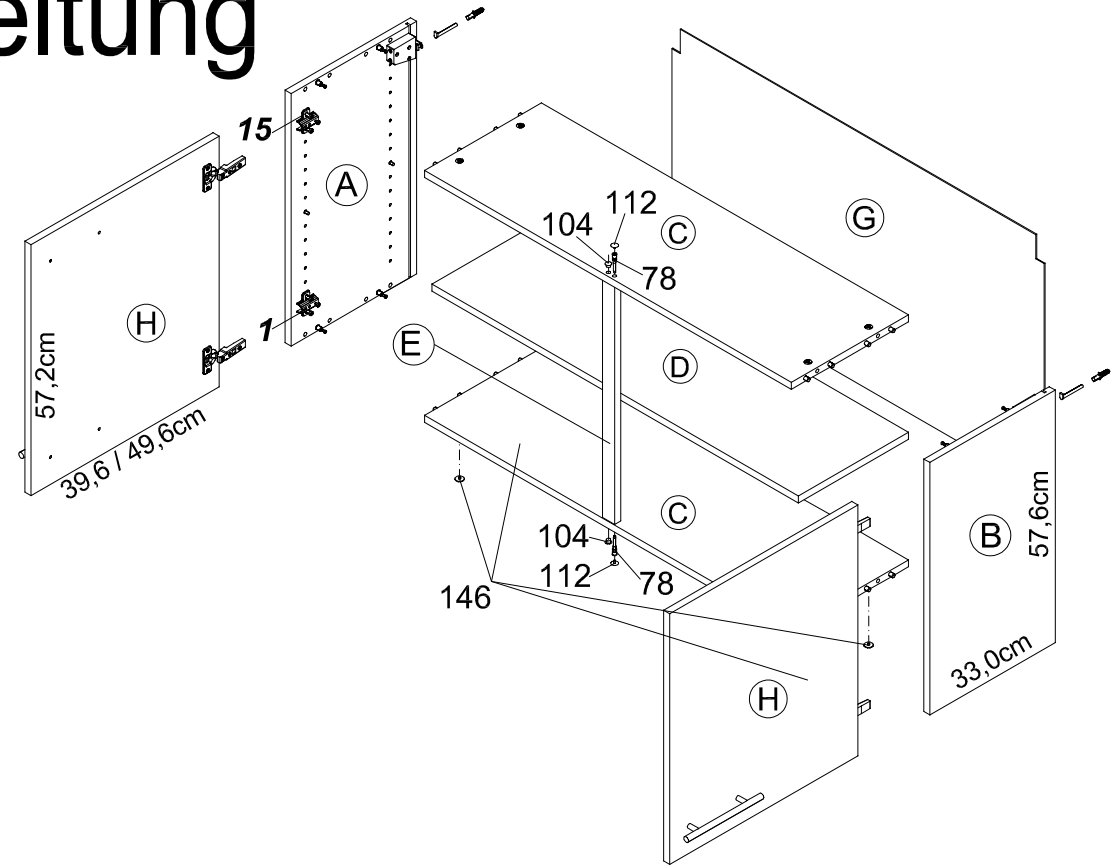
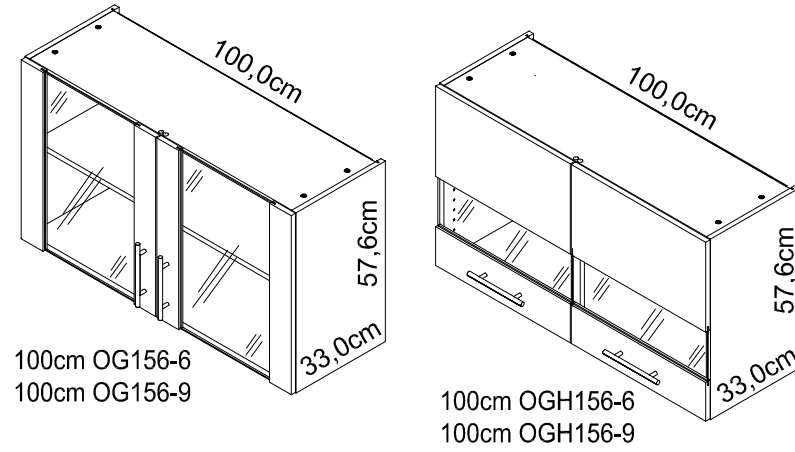
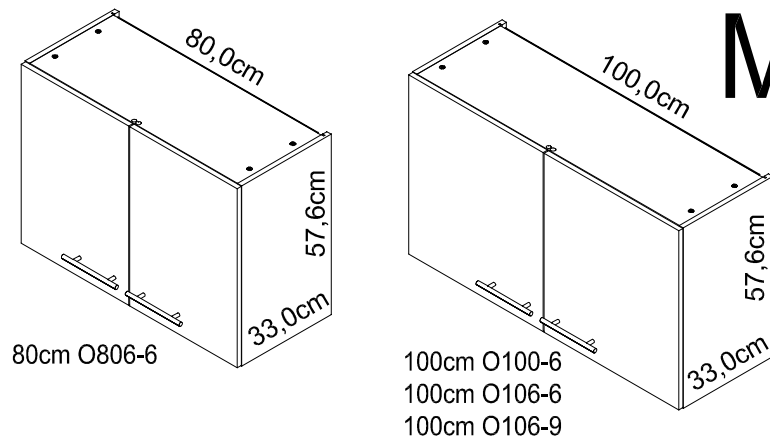

Ersatzteile/Spare parts/pièces de rechange/Reserveonderdelen/Piezas de recambio/Ricambi/Запасные части/Części zamienne/pótalkatrészek/Náhradní části/Nadomestni deli/varaosat/reservdelar/náhradné diely/Utilizați piese de schimb/Yedek parçalar

80cm O806-6	(A/B) E940036	(C) E941232	(D) E940332	(E) E940100	(G) E971009	(H) E940613	100cm OG156-6	(A/B) E940036	(C) E942231	(D) E941331	(E) E940100	(G) E971026	(H) E940647
100cm O100-6	(A/B) E940036	(C) E942231	(D) E941331	(E) E940100	(G) E971026	(H) E980612	100cm OG156-9	(A/B) E940036	(C) E942231	(D) E941331	(E) E940100	(G) E971026	(H) E940647
100cm O106-6	(A/B) E940036	(C) E942231	(D) E941331	(E) E940100	(G) E971026	(H) E980612	100cm OGH156-6	(A/B) E940036	(C) E942231	(D) E941331	(E) E940100	(G) E971026	(H) E940655
100cm O106-9	(A/B) E940036	(C) E942231	(D) E941331	(E) E940100	(G) E971026	(H) E940612	100cm OGH156-9	(A/B) E940036	(C) E942231	(D) E941331	(E) E940100	(G) E971026	(H) E940655

1 → 2 → 3 ...

- 3 4x Ø18/Ø4 Nr.146
- 2x Ø8/Ø13 Nr.104
- 2x 7x42 Nr.78
- 2x Ø3/Ø15 Nr.112
- 2x Nr.277
- 6x 4x30 Nr.164
- 16x Nr.204
- 4x Nr.365
- 4x OGH156 Nr.107
- 2x Ø8x40 Nr.70
- 2x Nr.69
- 2x 4x30 Nr.424

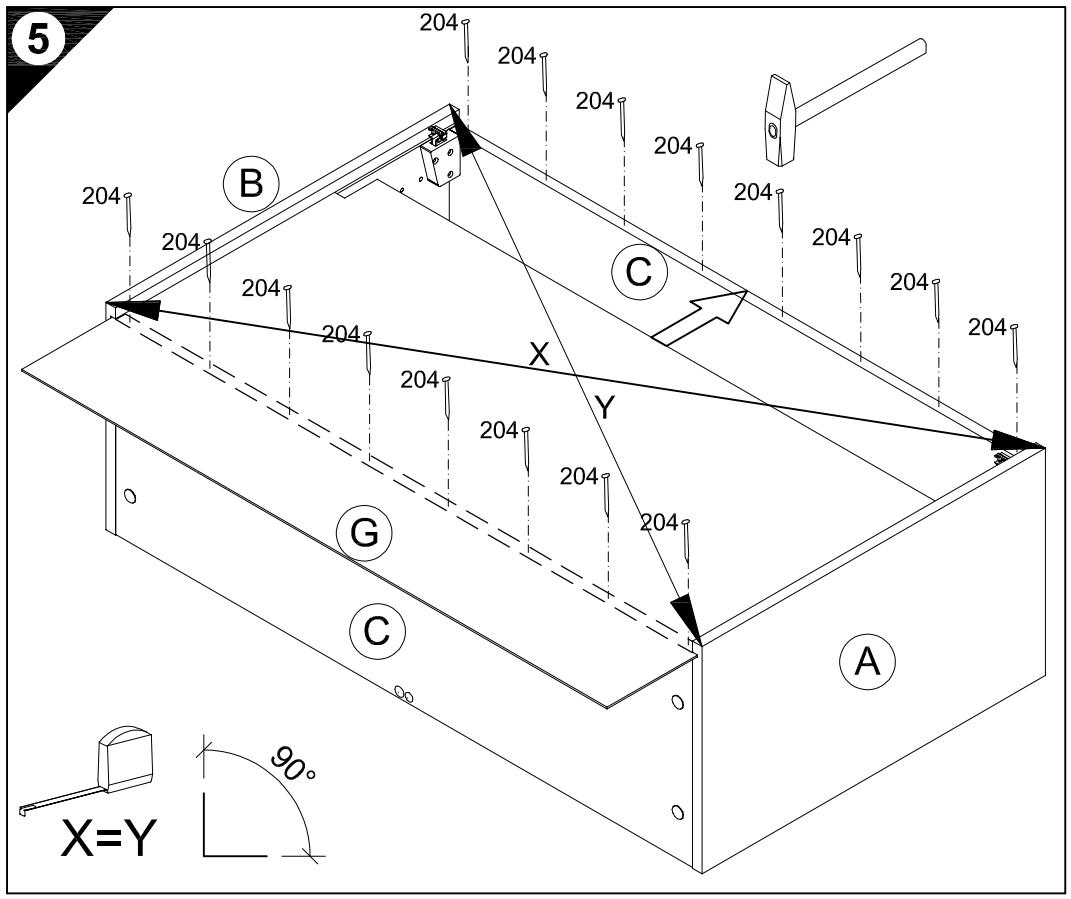
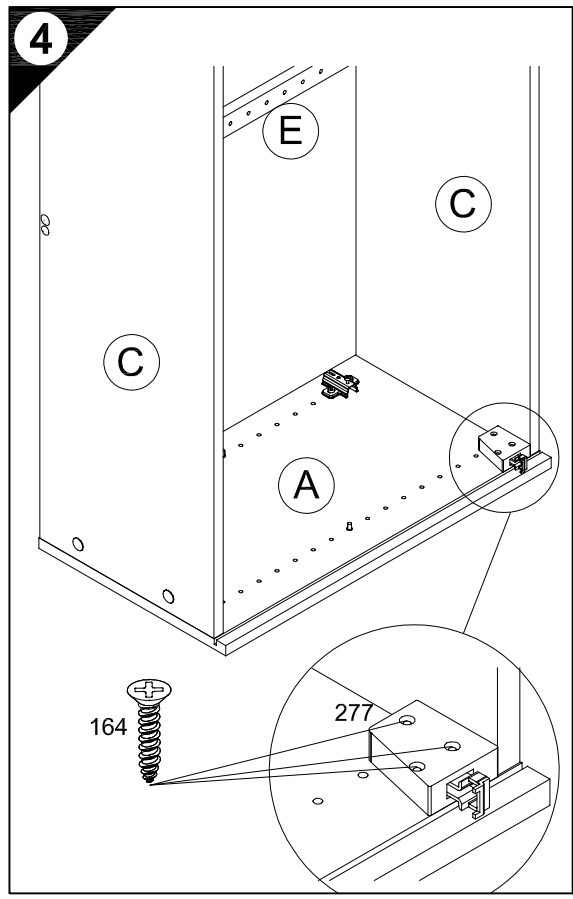
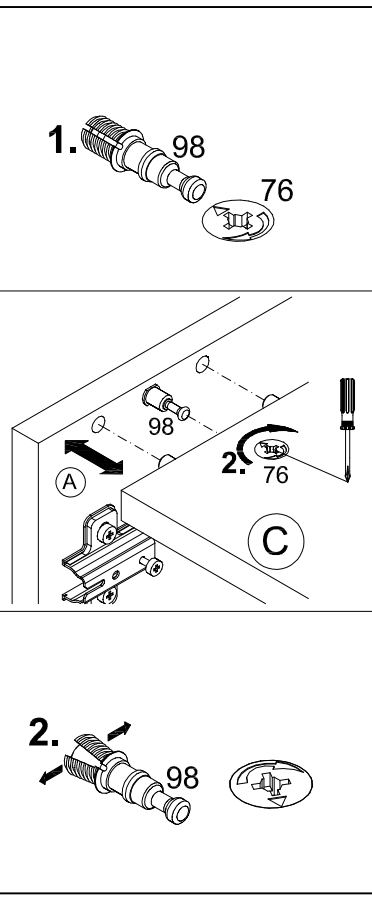
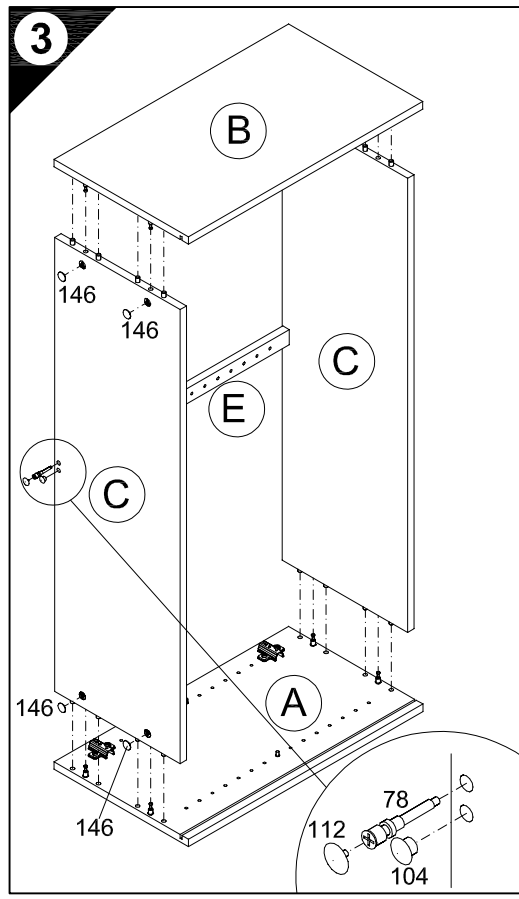
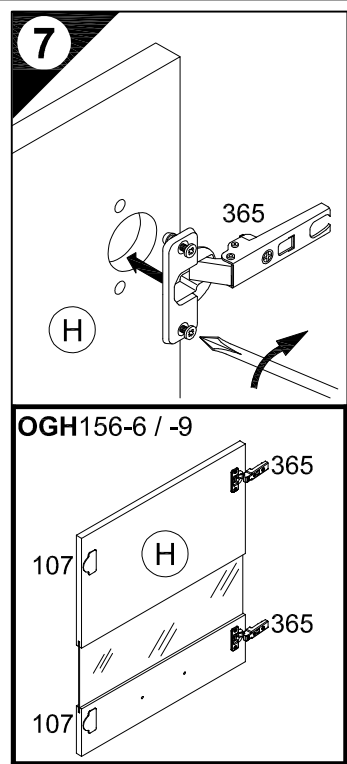

6

- |  |   |
|--|---|
| <p><b>D</b> Holzunterlage verwenden!<br/>Front andrücken, scharfen Bohrer verwenden und mit wenig Druck durchbohren!</p> <p><b>GB</b> Use a wooden base!<br/>Press front down, use sharp drill bit and, by applying slight pressure, drill a hole</p> <p><b>F</b> Utiliser un support en bois !<br/>Appuyer sur la façade, utiliser un foret bien affûté et percer en appliquant une faible pression !</p> <p><b>NL</b> Houten onderlegger gebruiken!<br/>Druk het front aan, gebruik een scherpe boor en oefen bij het boren weinig druk uit!</p> <p><b>E</b> ¡Utilizar una base de madera!<br/>¡Presionar el frente, utilizar una broca afilada y taladrar con poca presión!</p> <p><b>I</b> Utilizzare una base di legno!<br/>Appoggiare la facciata, utilizzare una punta di trapano affilata e trapanare esercitando solo una leggera pressione!</p> <p><b>RUS</b> Использовать деревянную подложку!<br/>Прижать фасад, использовать острое сверло и просверлить с незначительным давлением!</p> <p><b>PL</b> Używać podkładkę z drewna!<br/>Docisnąć front, użyć ostrego wiertła i przewiercić, używając małej siły nacisku!</p> | <p><b>H</b> Alkalmazzon fa alátétet!<br/>Nyomja le az előlapot, használgjon éles fúrót, és kis nyomással fúrja át!</p> <p><b>CZ</b> Použijte dřevěný podklad!<br/>Přitlačte čelo, použijte ostrý vrták a provrtějte pomocí malého tlaku!</p> <p><b>SLO</b> Uporabite leseno podlago!<br/>Pritisnite ličnico ter z ostrim svedrom in z majhnim pritiskom izvrtajte luknjo!</p> <p><b>FIN</b> Käytä puualustaa!<br/>Paina etulevy paikoilleen, käytä terävää poranterää ja poraa reikä vain kevyesti painamalla!</p> <p><b>S</b> Använd ett träunderlag!<br/>Tryck fronten mot underlaget, använd vass borrh och borra igenom med ett lätt tryck!</p> <p><b>SK</b> Použite drevený podklad!<br/>Přitlačte front, použijte ostrý vrták a prevrtajte miernym tlakom!</p> <p><b>RO</b> suport de lemn!<br/>Împingeți frontul, utilizați un burghiu ascuțit și perforați exercitând doar o presiune redusă!</p> <p><b>TR</b> Ahşap taban kullanın!<br/>Önden bastırın, keskin matkap ucu kullanın ve az basınç uygulayarak delin!</p> |
|--|---|

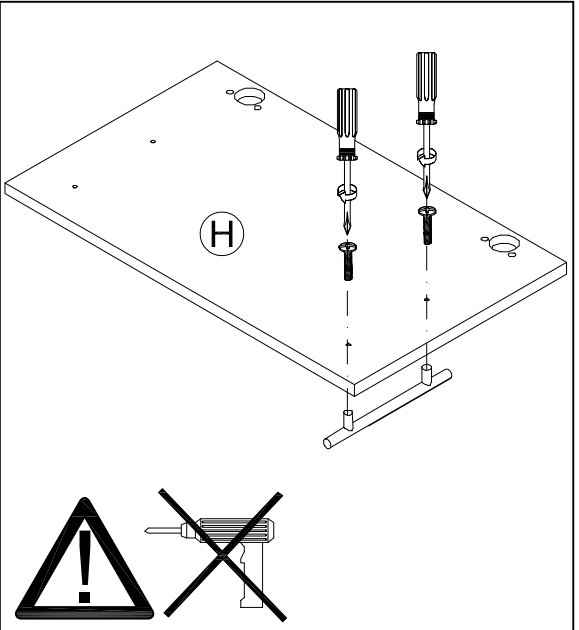
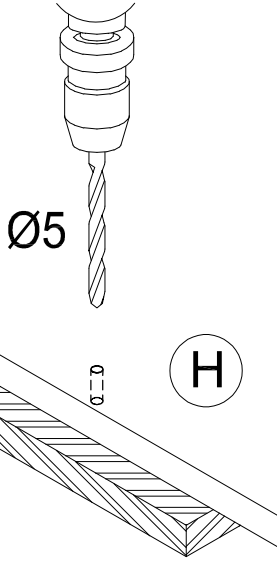

8

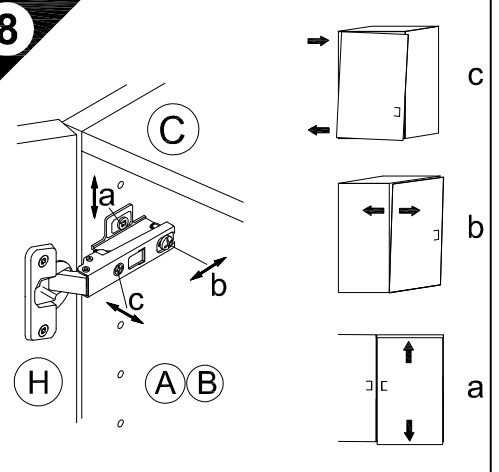

9

- |  |  |
|--|--|
| <p><b>D</b> Untergrund und Befestigungsmittel auf Eignung prüfen!</p> <p><b>GB</b> Check substructure and fixings for suitability!</p> <p><b>F</b> Contrôler si le support et les moyens de fixation sont bien adéquats !</p> <p><b>NL</b> Ondergrond en bevestigingsmateriaal op functionaliteit controleren!</p> <p><b>E</b> ¡Comprobar el suelo y los medios de fijación en cuanto a su aptitud!</p> <p><b>I</b> Controllare l'idoneità del fondo e del materiale di fissaggio!</p> <p><b>RUS</b> Основание и крепежный материал проверить на пригодность!</p> <p><b>PL</b> Podłoże oraz materiały do zamocowania sprawdzić na ich przydatność!</p> <p><b>H</b> Az alapfelületet és a rögzítő anyagokat megfelelőség szempontjából ellenőrizni kell!</p> <p><b>CZ</b> Přezkoušejte podklad a vhodnost upevňovacích prostředků!</p> <p><b>SLO</b> Preverite, če se ujemajo spodnja stran in pritrdilna sredstva!</p> <p><b>FIN</b> Tarkista alustan ja kiinnitysvälineiden sopivuus!</p> <p><b>S</b> Kontrollera att underlaget och fästmedlen är lämpliga!</p> <p><b>SK</b> Preverte vhodnosť podkladu a upevňovacích prostriedkov!</p> <p><b>RO</b> Verificați caracterul adecvat al suprafeței suport și al mijloacelor de fixare!</p> <p><b>TR</b> Zeminin ve bağlanı elementlerinin uygunluğunu kontrol edin!</p> |  |
|--|--|

10

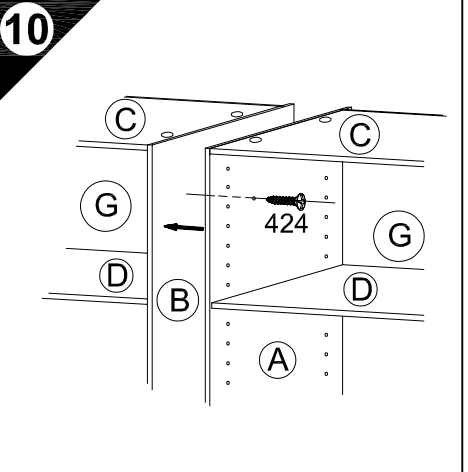

# SERVICEKARTE

VH

Liebe Kundin, lieber Kunde,

obwohl wir unsere Möbel vor der Auslieferung einer eingehenden Endkontrolle unterziehen, kann es vorkommen, dass einmal ein Zubehörteil fehlt oder während des Transports beschädigt wird. Senden sie den Artikel bitte nicht zurück, sondern fordern sie einfach Ersatz für das Einzelteil bei unserer Kundenhotline an. Die Telefonnummern finden sie auf den Serviceseiten im Katalog.

Bitte benennen sie die Teile wie sie auf ihrer Aufbauanleitung angegeben sind. Fügen sie auch **Artikelnummer, Modellnamen und Farbnummer** bei. **Siehe Beispiel.**

Wir werden ihre Anforderung sofort bearbeiten und ihnen das Ersatzteil umgehend zusenden.



Muster - Bestellung		
Artikelnummer	123 456	
Modellname	Unterschrank VU634	
Farbe	TA 01	
Benötigte Ersatzteile:		
Bezeichnung	Nr.	Anzahl
Beschlagteil	98	2
Teil B	E 440 023	1

Bitte entnehmen sie die notwendige Ersatzteilnummer der Aufbauanleitung die zum Möbel gehört!

Kundendaten	
Kundennummer	
Name	
Vorname	
Strasse	
Haus-Nr.	
PLZ	
Ort	
Rechnungsdatum	
Tel. für Rückfragen	
Notizen:	

Ersatzteilbestellung		
Artikelnummer		
Modellname		
Farbe		
Benötigte Ersatzteile:		
Bezeichnung	Nr.	Anzahl
Grund der Ersatzteilanforderung:		