

Art. Nr. 7248 4237, 2348 6048

LKZ 41164

7248 4237

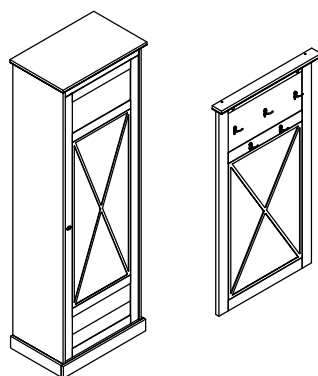
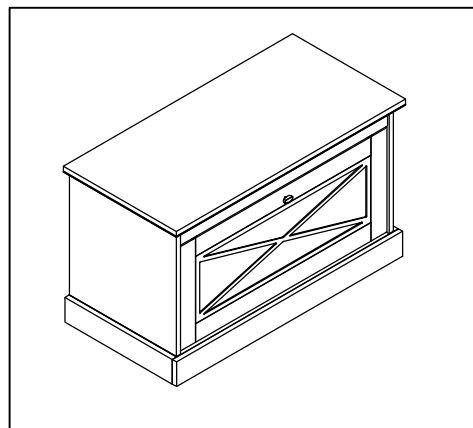

2348 6048

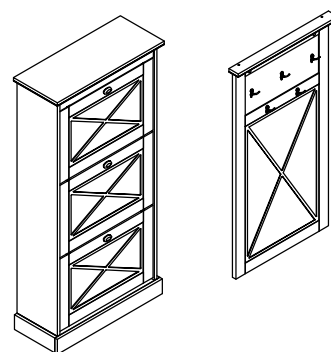
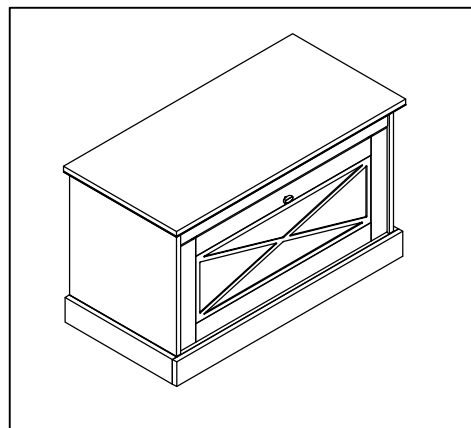

- | | |
|---|-------------------------------------|
| (D) Montageanleitung | (GB) Assembly instructions |
| (FR) Notice de montage | (IT) Istruzioni di montaggio |
| (NL) Handleiding voor de montage | (PL) Instrukcja montazu |
| (CZ) Montážní návod | (SK) Návod na montáž |
| (HU) Szerelési útmutató | (RO) Instrucțiuni de montaj |
| (TR) Montaj talimatı | (RU) Инструкция по монтажу |

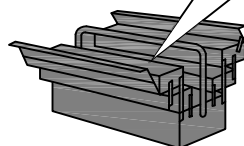
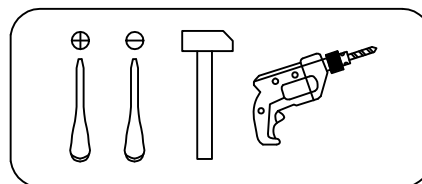

0
10
20
30
40
50
60
70
80
90
100

A 090913 7x32 x22	B 000146 15x12 x22	C 100640 20x0.5 x8	D 000151 8x35 x20	E 135021 x8	F 000759 3x20 x8
G 125913 x4	H 214356 x1	I 013794 M4x22 x1	J 168847 x2	K 235594 6,3x16 x4	L 010942 4x16 x12
M 120144 x2	N 155999 x1	O 000754 3.5x16 x2	P 013859 8x40 x1	Q 090185 4.5x45 x1	R 230041 22x16 x4
S 238965 home affaire x1					

N	Size/MaB (mm)	Qty	✓	N	Size/MaB (mm)	Qty	✓
1	412x400x16	1		8	858x423x38	1	
2	412x400x16	1		9	814x402x16	1	
3	780x66x16	1		10	776x338x16	1	
4	402x80x16	1		11	780x354x16	1	
5	402x80x16	1		12	790x422x3	1	
6	846x80x16	1					
7	814x64x16	2					

Service - Dienstverlening - Serwis - Servis - Сервисная служба

Name - Naam - Nazwa - Isim - Название

Nr. - No. - Номер

Typ - Type - Тип - Тип

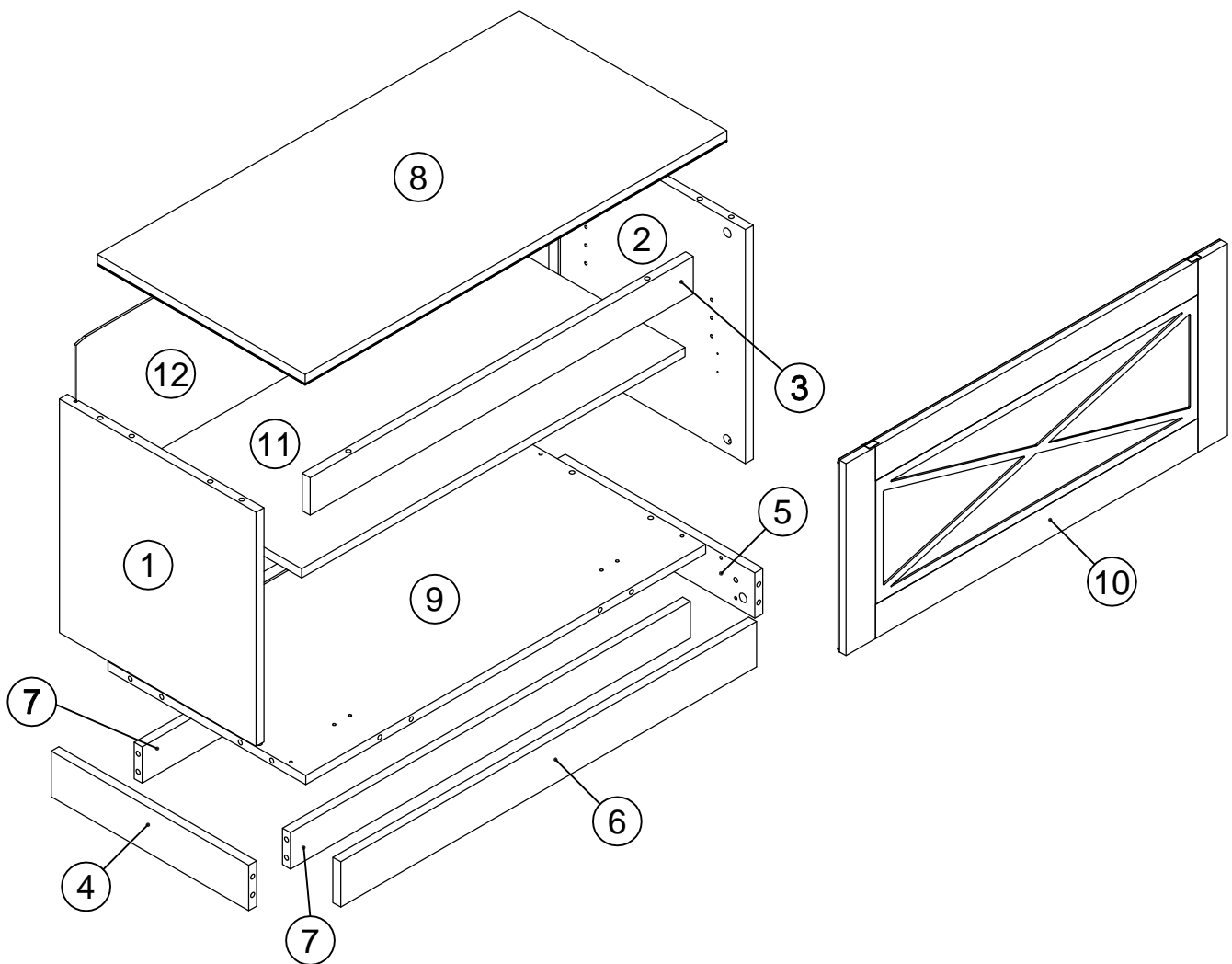
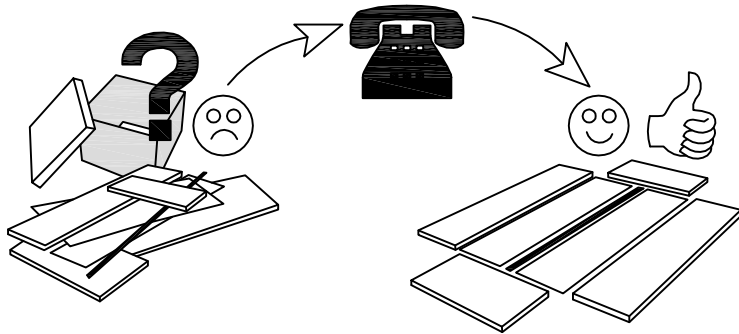
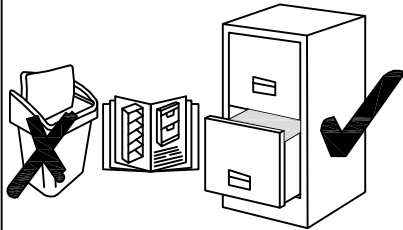

1

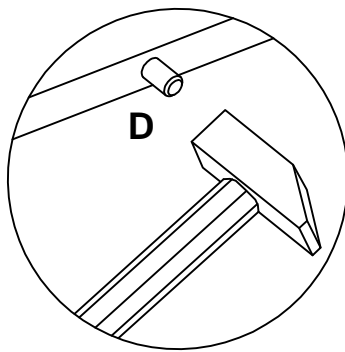
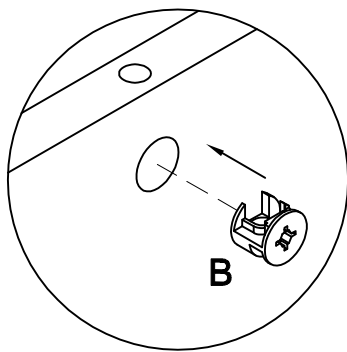
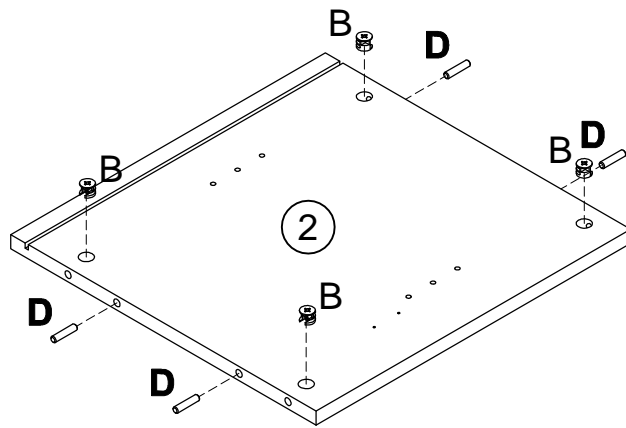
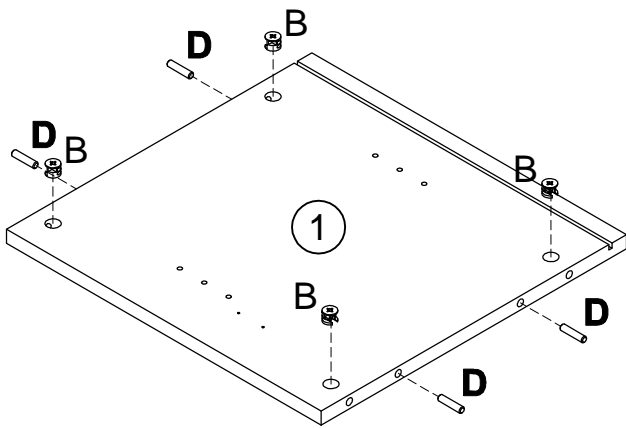
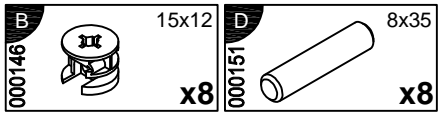

2

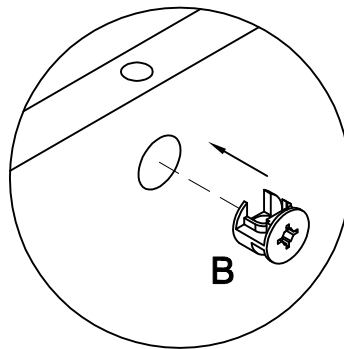
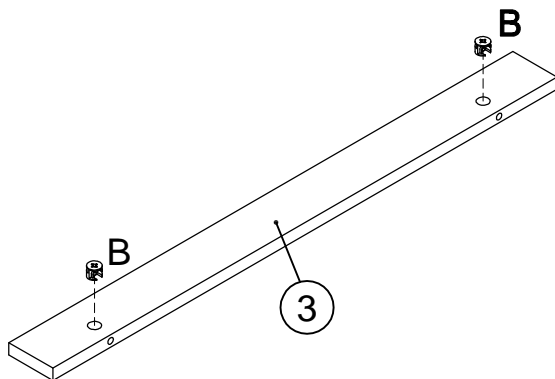
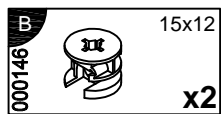

3

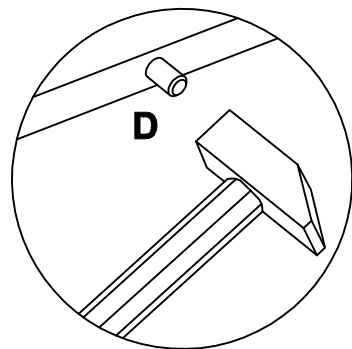
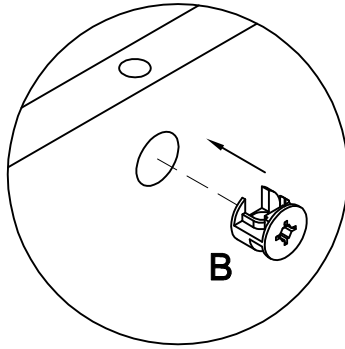
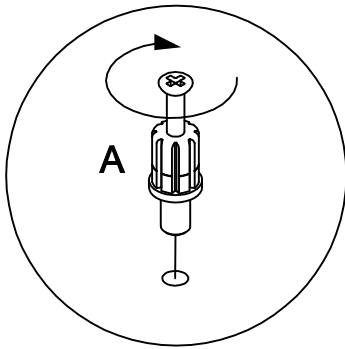
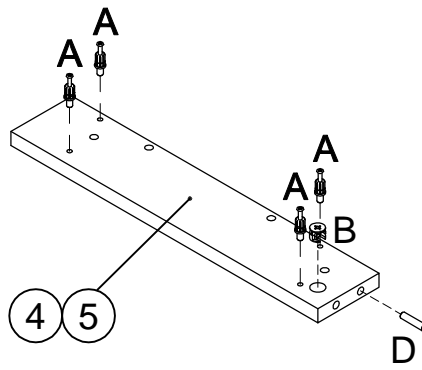
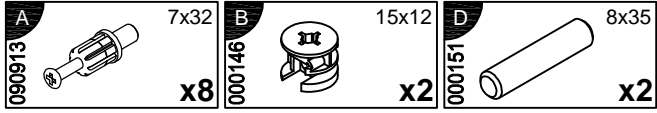

4

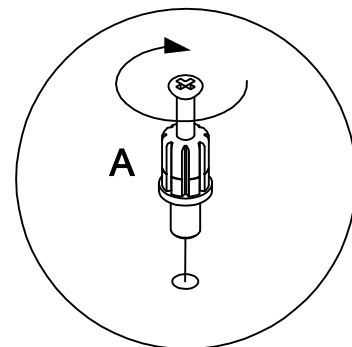
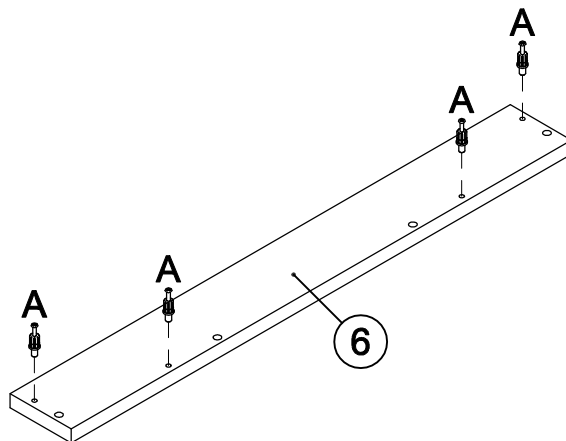
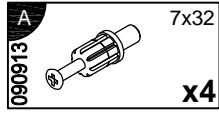

5
x2

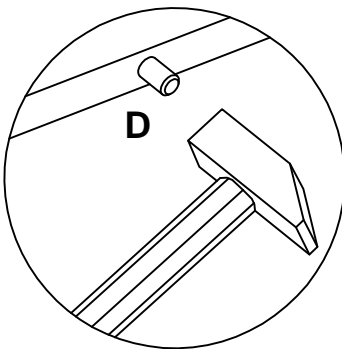
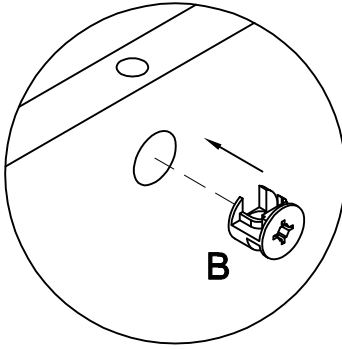
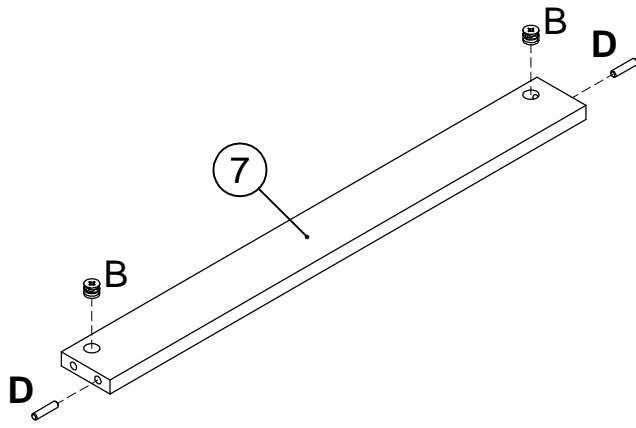
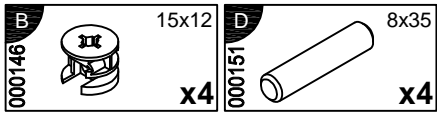

6

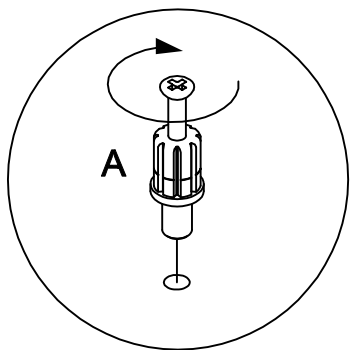
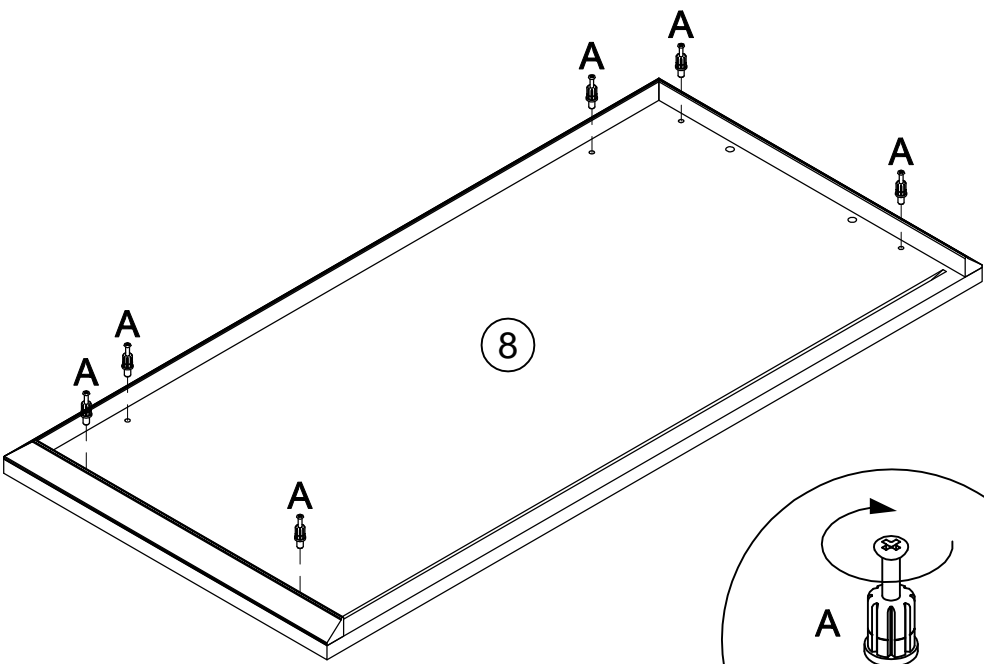
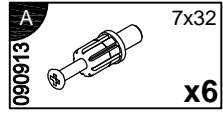

7

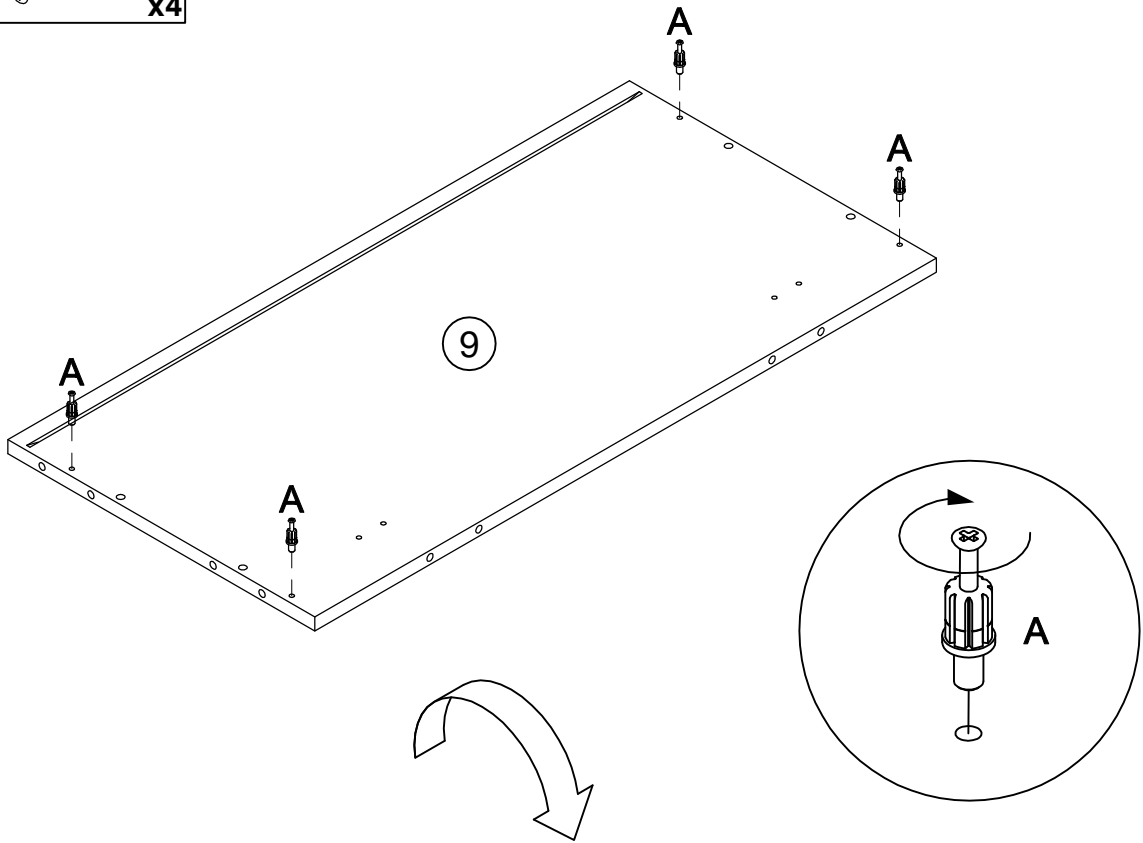
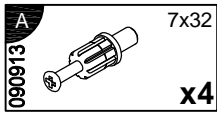

8

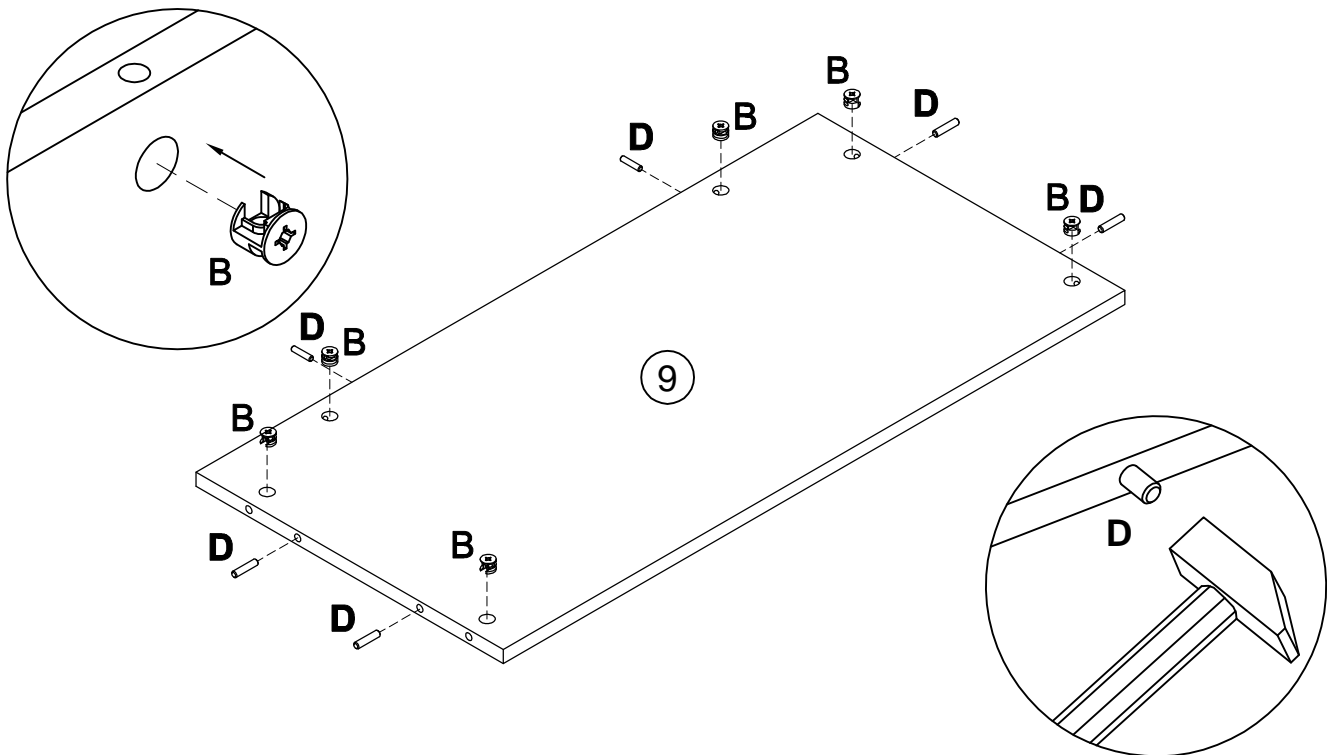
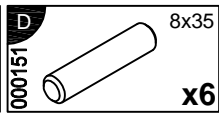
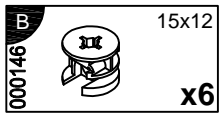

9

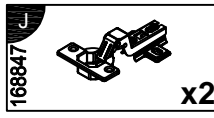
- 

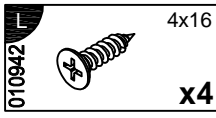
168847 **J** x2
- 

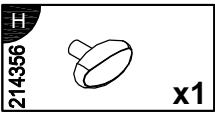
010942 **L** 4x16 x4
- 

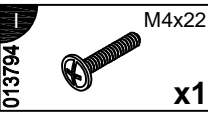
214356 **H** x1
- 

013794 **I** M4x22 x1

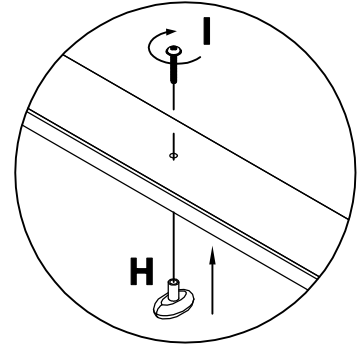
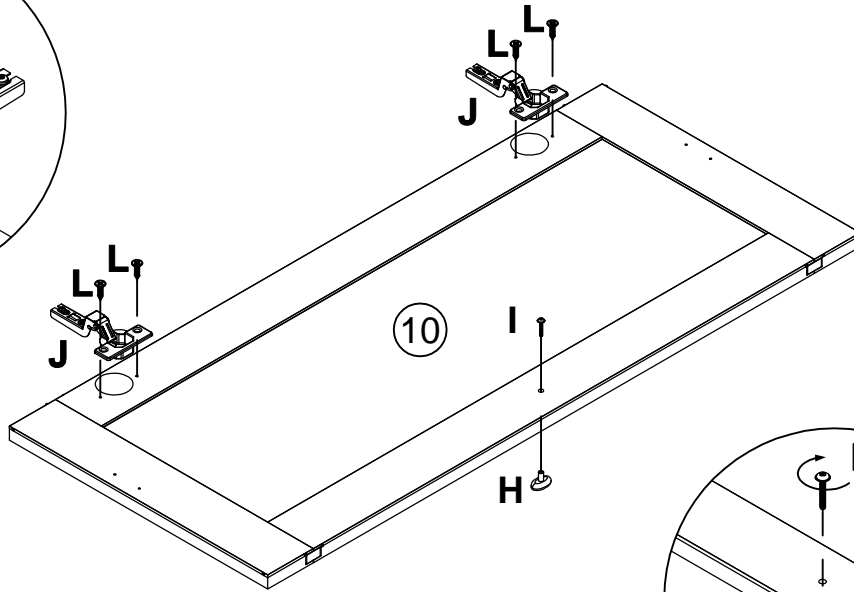
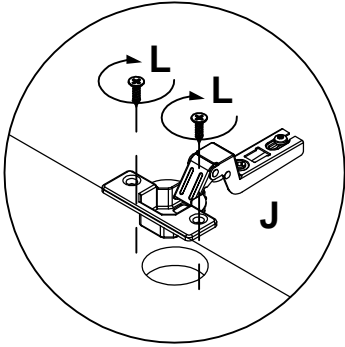

10

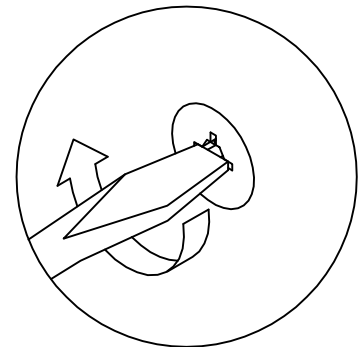
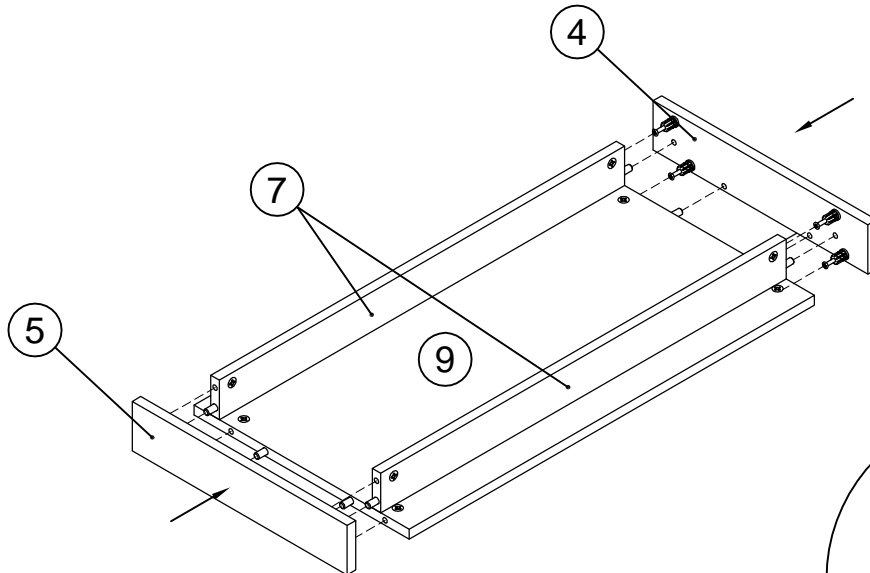

11

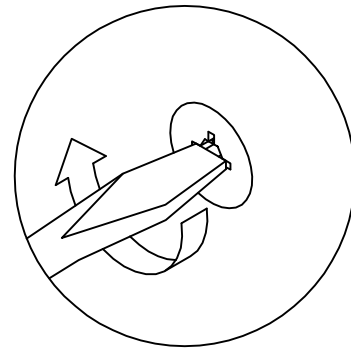
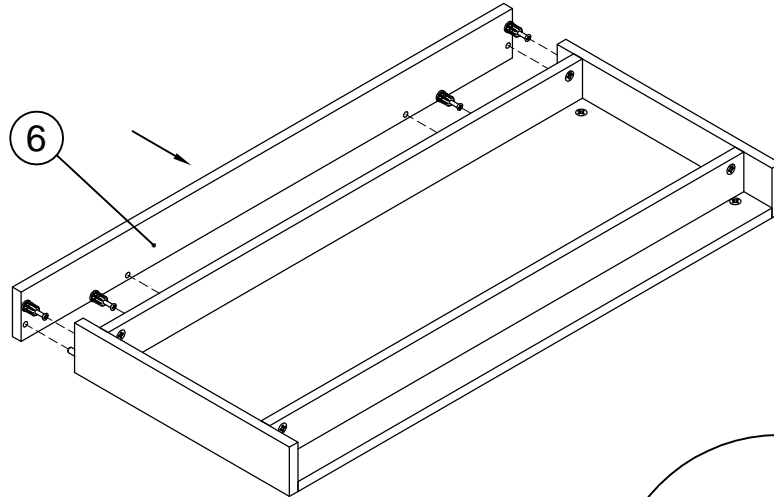

12

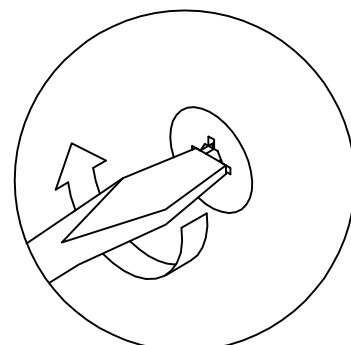
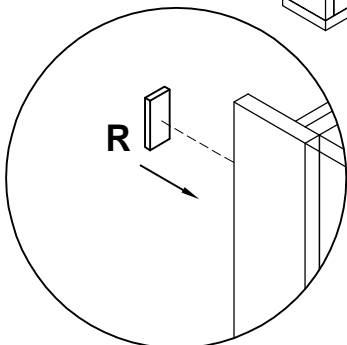
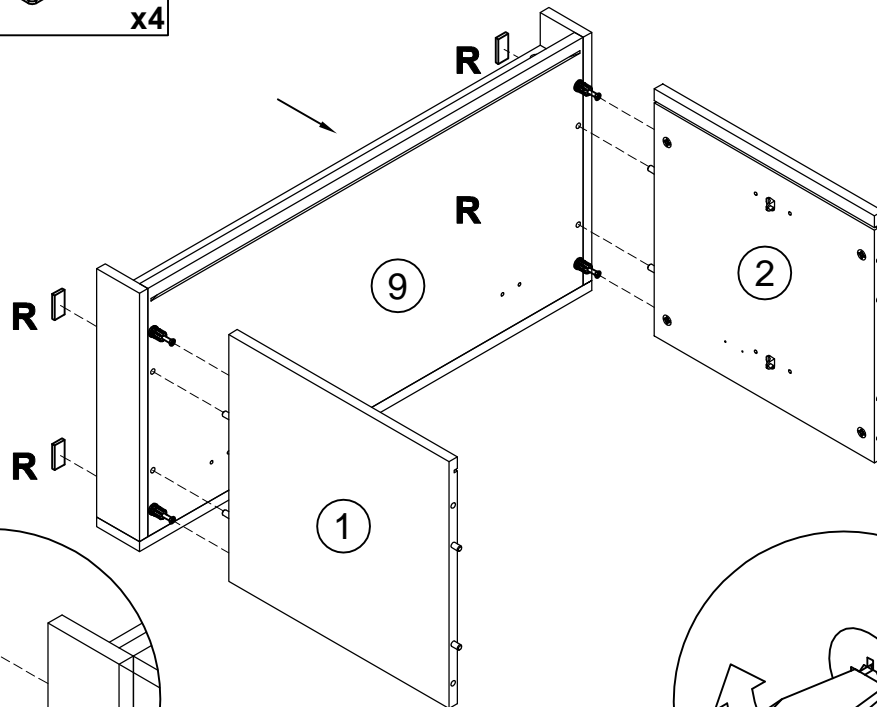
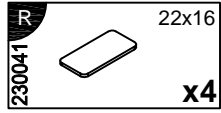

13

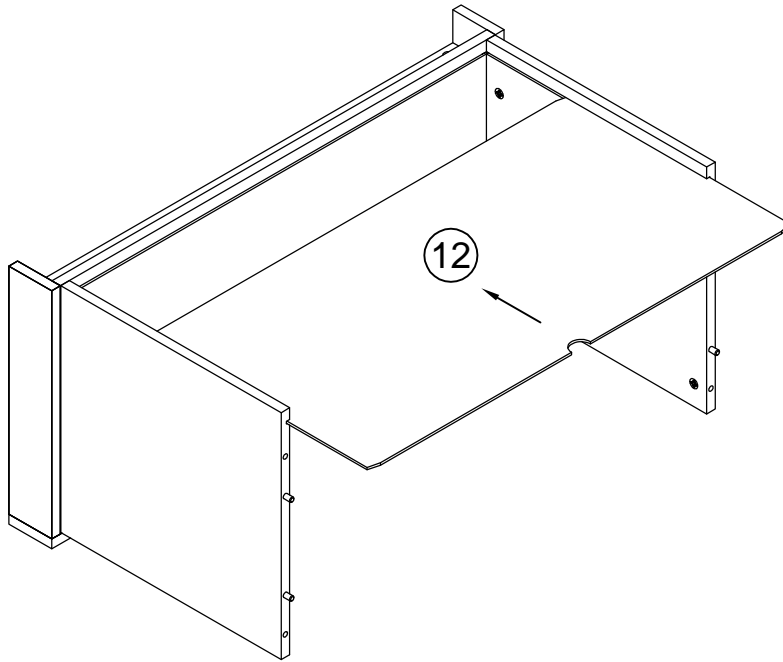

14

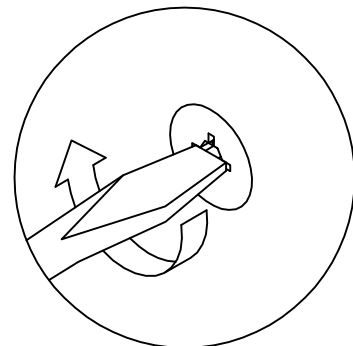
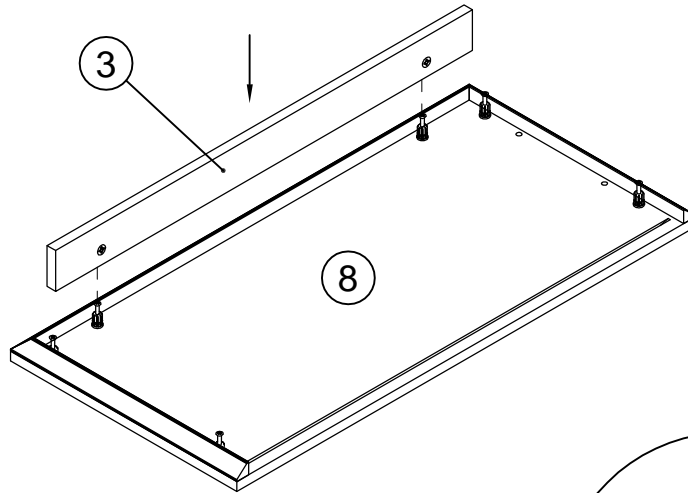

15

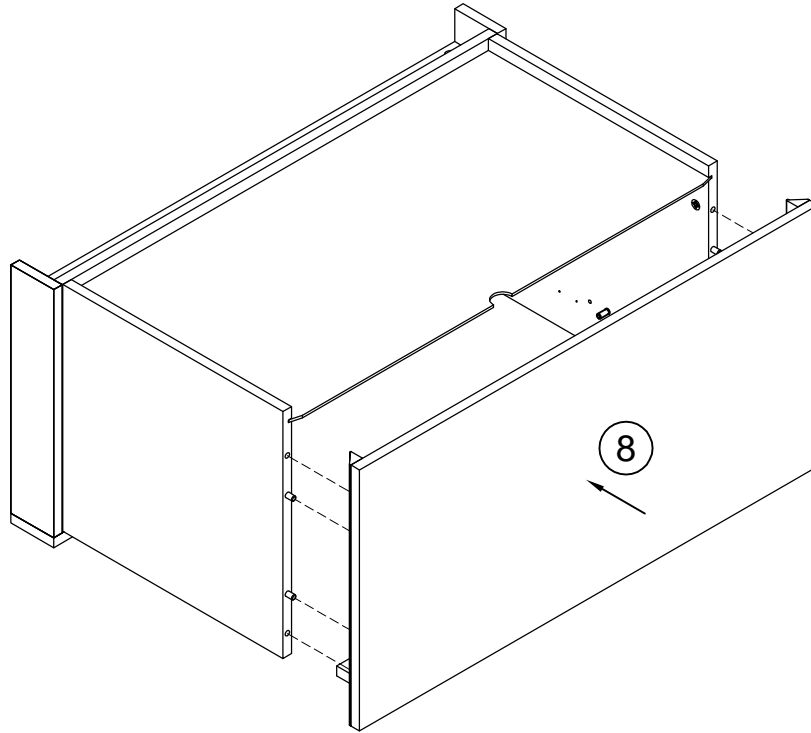

16

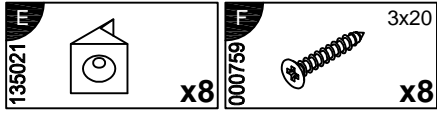

L1=L2

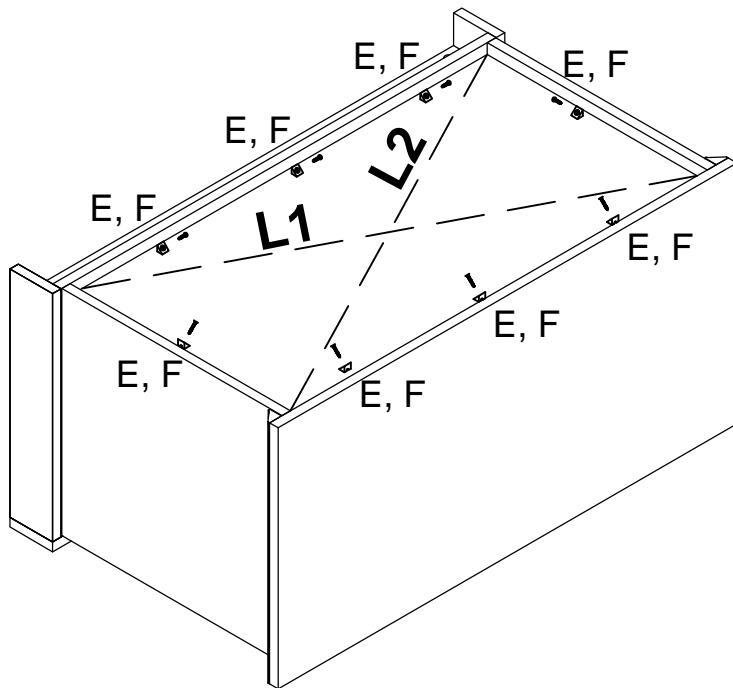
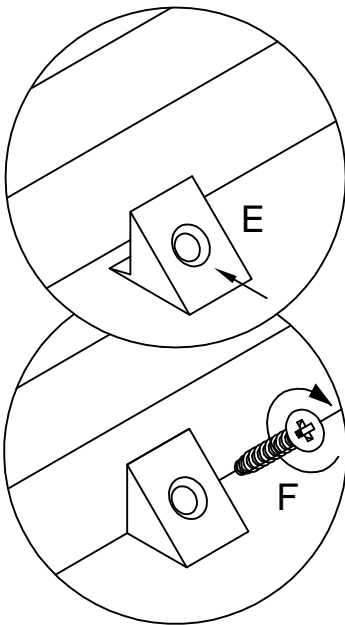

17

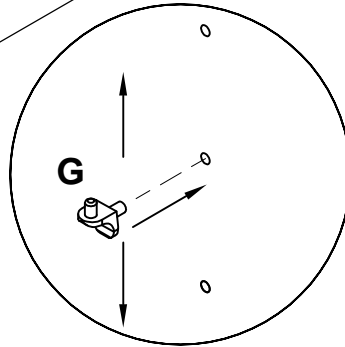
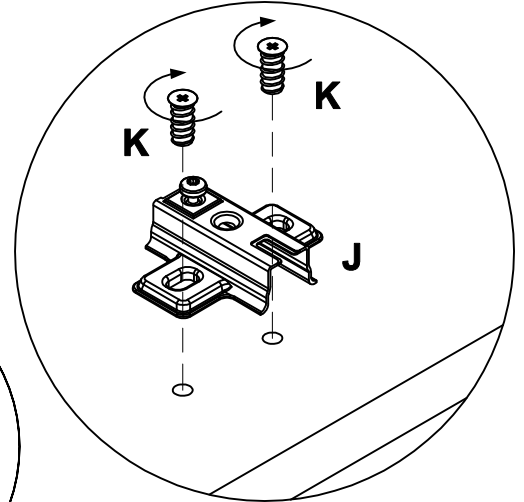
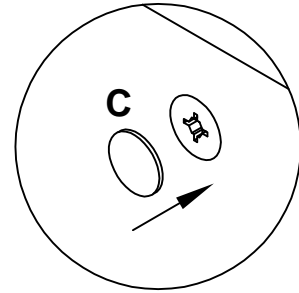
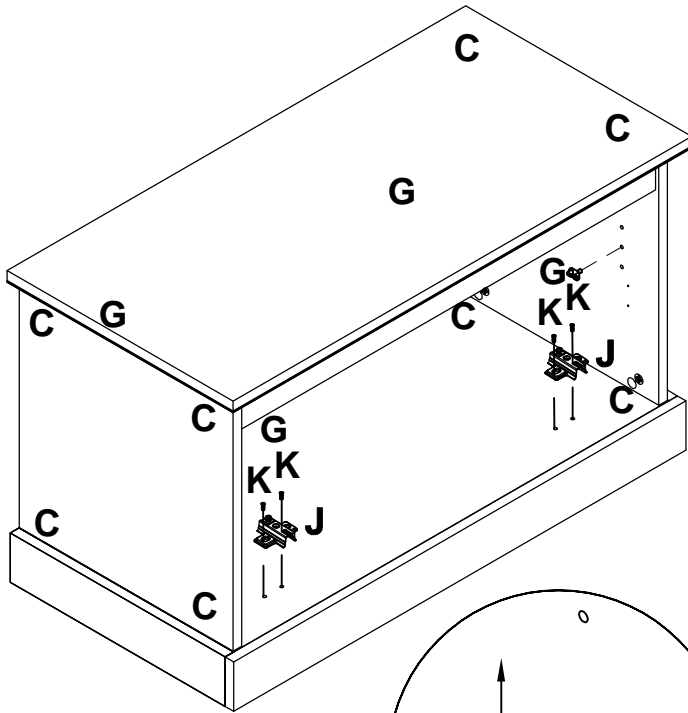
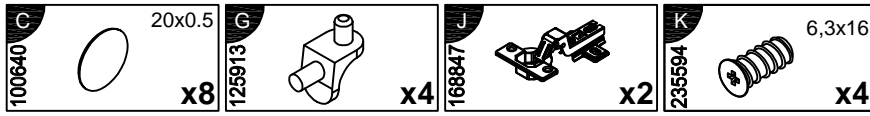

18

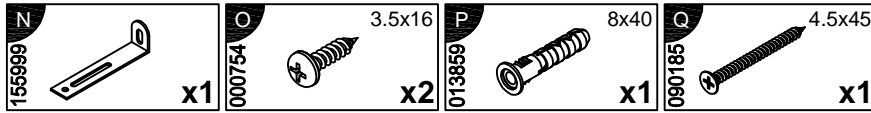

N, O, P, Q

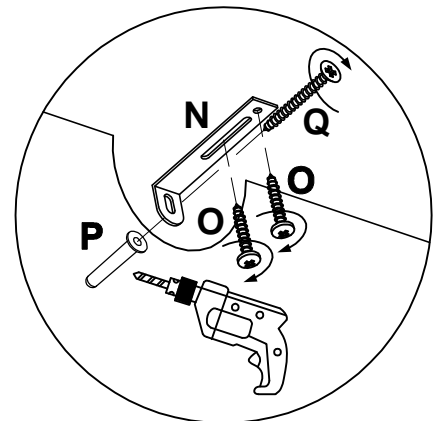
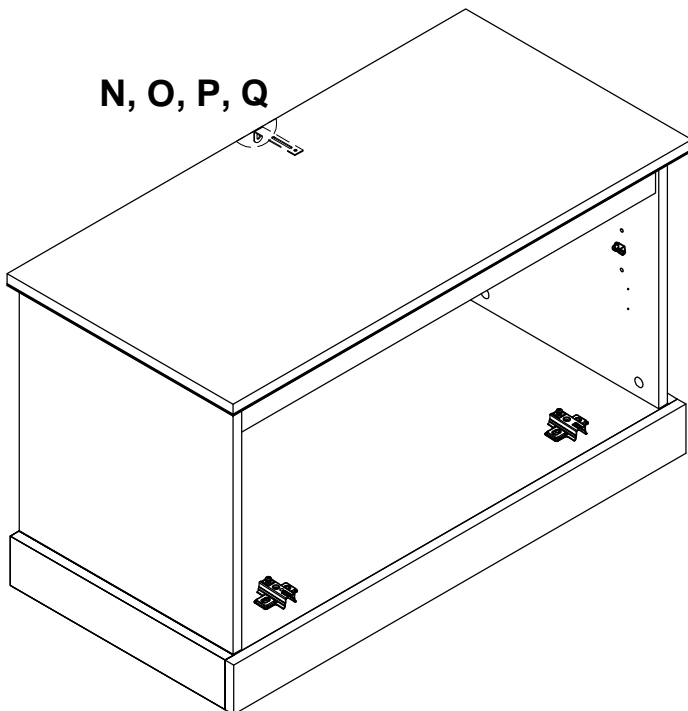

19

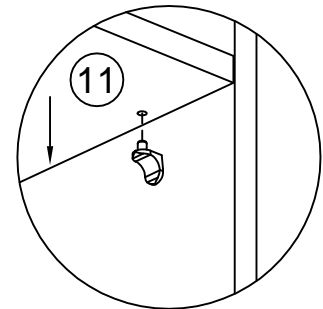
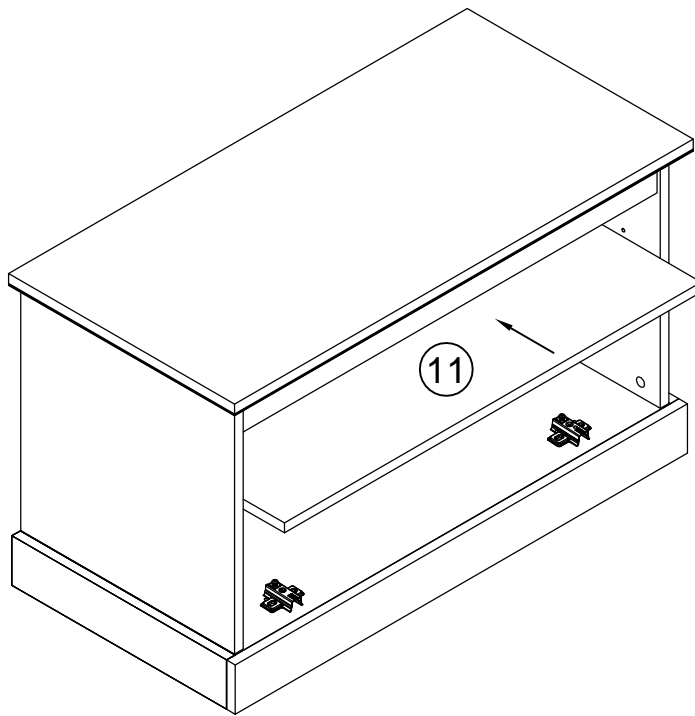

20

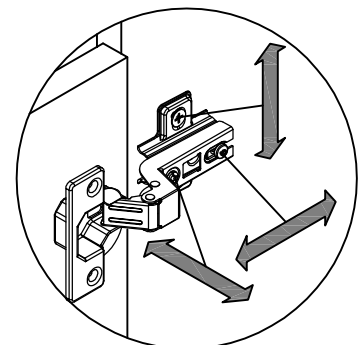
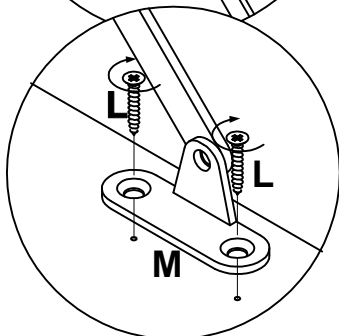
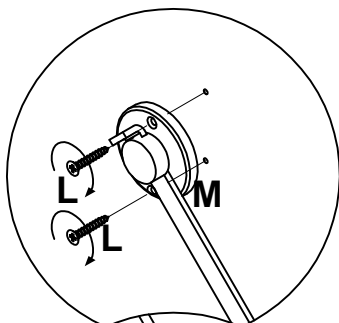
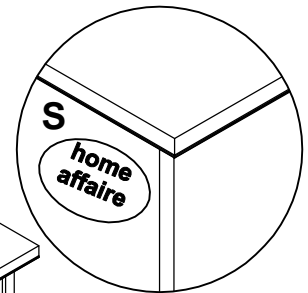
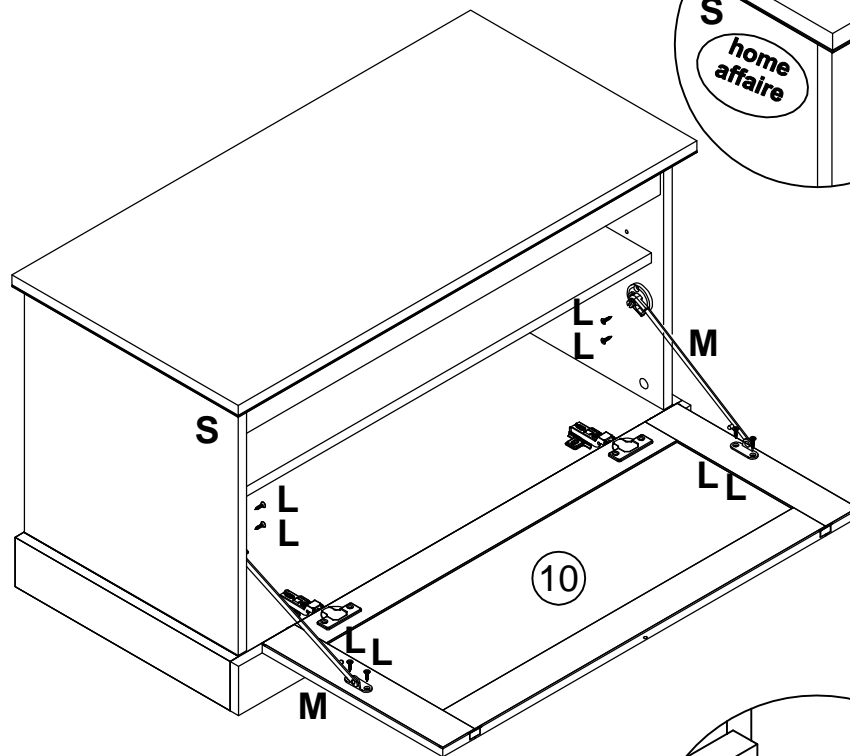
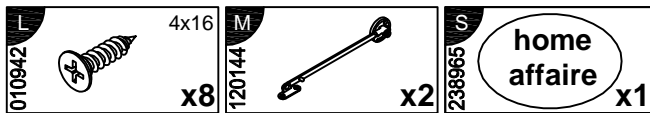



Achtung • Attention • Attenzione
Opgelet • Uwaga • Pozor • Figyelem
Atenție • Dikkat • Внимание

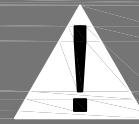

(D)	Wandbefestigung dient als Kippschutz – unbedingt anbringen! Bei einigen Wandtypen kann ein Spezialdübel erforderlich sein!
(GB)	The wall fastening serves to prevent tipping – be absolutely sure to mount it! For certain wall types, a special wall plug may be necessary!
(FR)	La fixation murale sert de protection contre le basculement – à installer impérativement ! Pour certains types de murs il faut des chevilles spéciales !
(IT)	Il fissaggio alla parete serve da protezione anti-ribaltamento – attaccarla assolutamente ! Per alcune strutture di parete può essere necessario un tassello speciale !
(NL)	Bevestiging aan de muur dient als kantelbescherming – zeker en vast bevestigen ! Bij enkele muurtypes is een speciale plug misschien vereist !
(PL)	Mocowanie do ściany jest jednocześnie zabezpieczeniem przed przewróceniem – koniecznie zamontować! Do niektórych rodzajów ścian koniecznie zastosować specjalne kołki mocujące.
(CZ)	Montáž na stěnu slouží jako ochrana proti převrnutí – bezpodmienečně umístěte! Uněkterých typů stěn může být zapotřebí speciální hmoždinka !
(SK)	Upevnenie na stenu slúži ako ochrana proti prevráteniu – bezpodmienečne použite! Pre niektoré druhy stien môže byť potrebná špeciálna hmoždenka !
(HU)	A terméket a falhoz kel rögzíteni, különben az felborulhat! Egyes faltípusoknál speciális tiplit kell használni !
(RO)	Sistemul de fixare la perete serve ște ca protecție la răsturnare – de montat obligatoriu! Pentru unele tipuri de pereți este posibil să fie necesar un diblu special !
(TR)	Duvardaki sabitleme, devrilmeye karşı bir emniyet tedbiridir ve mutlaka monte edilmelidir! Bazı duvar tiplerinde bunun için özel bir dübel gereklidir !
(RU)	Обязательно установите крепление на стене во избежание опрокидывания ! Для некоторых типов стен может потребоваться специальный дюбель !