

# ECKBANK TRIO

## ASSEMBLY INSTRUCTION CORNER BENCH - AUFBAUANLEITUNG - INSTRUKCJA MONTAŻU - MONTÁŽNÍ NÁVOD

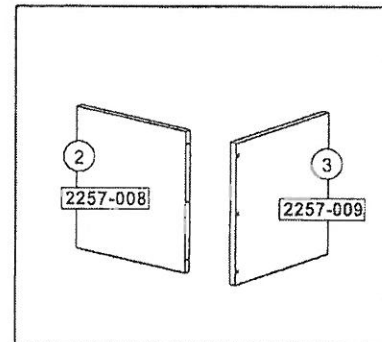

<p><b>TYP 1</b></p> <p>1100 mm - 2200-9011 1250 mm - 2202-9011 1400 mm - 2204-9011 1500 mm - 2200-9010 1650 mm - 2202-9010 1800 mm - 2204-9010</p>	<p>1100 mm - 2862-018 1250 mm - 2864-018 1400 mm - 2866-018 1500 mm - 2862-017 1650 mm - 2864-017 1800 mm - 2866-017</p>
<p><b>TYP 2</b></p> <p>450 mm - 2862-9010</p>	
<p><b>TYP 3</b></p> <p>1020 mm - 2248-9011 1170 mm - 2250-9011 1320 mm - 2252-9011 1420 mm - 2248-9010 1570 mm - 2250-9010 1720 mm - 2252-9010</p>	<p>1100 mm - 2848-007 1250 mm - 2850-007 1400 mm - 2852-007 1500 mm - 2848-006 1650 mm - 2850-006 1800 mm - 2852-006</p>

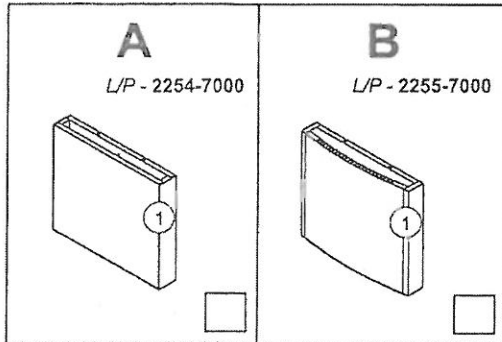
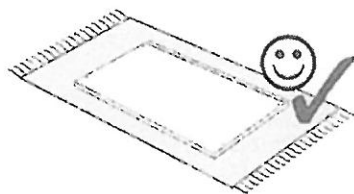
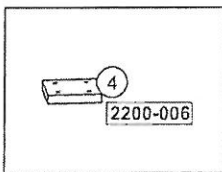

**SCHÖSSWENDER**  
DER ESSGRUPPENSPEZIALIST

Zde si můžete změřit kování k přesnému určení typu dle velikosti. Všechny rozměry jsou uvedeny v milimetrech.  
Here, you can measure the furniture hardware to recognise a certain part according to its size. All proportions are in millimetre.  
Hier können Sie die Schrauben zur besseren Identifizierung nachmessen (alle Maßangaben in mm).  
Tu možna zmierzyc okovje w celu dokladnego przeznaczenia typu wg wielkości. Wszystkie wymiary podane są w milimetrach.  
Itt lemérheti a vasalatot a típus méret szerinti pontos meghatározásához. Valamennyi méret milliméterben megadva.  
Tukaj lahko spremerite okovje in natančno določite tip in velikost. Merske enote vseh dimenzij so milimetri.  
Tu si môžete odmerať kovanie na presné určenie typu podľa veľkosti. Všetky rozmery sú uvedené v milimetroch.

SCHÖSSWENDER Möbel GmbH, A-5131 Franking 65  
Tel: +43 (0)6277 / 8651, Fax: +43 (0)6277 / 8651-400  
info@schosswender.at, www.schosswender.at  
FN: 35113 m b e l m Firmenbuch Ried i. Innkreis

60 min.

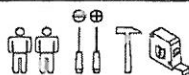

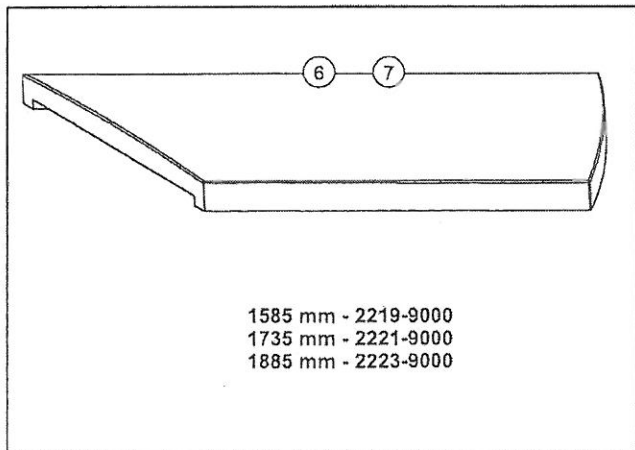
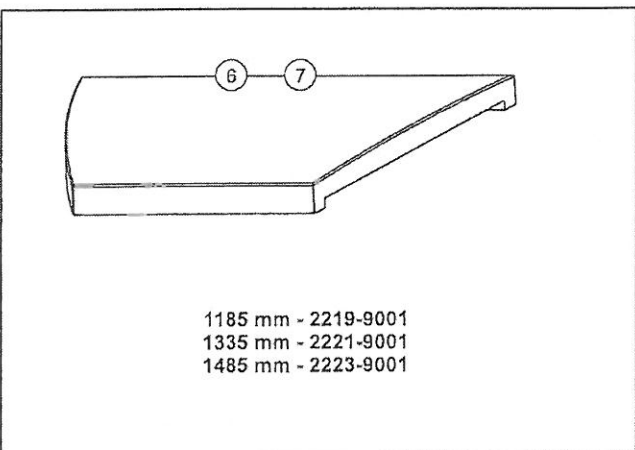
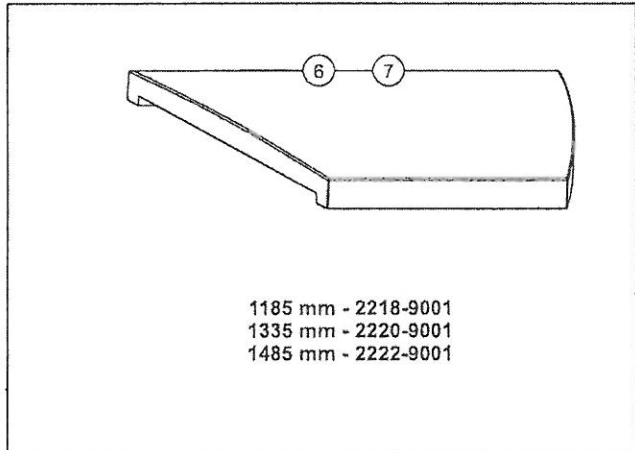
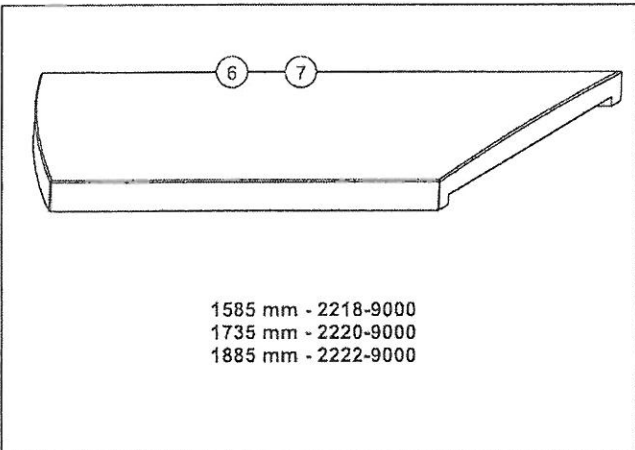
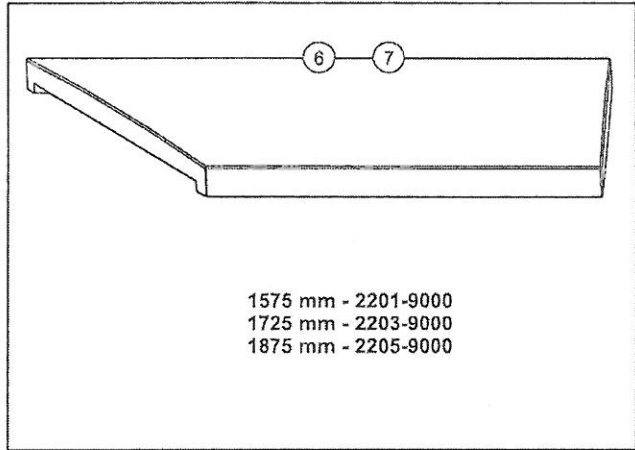
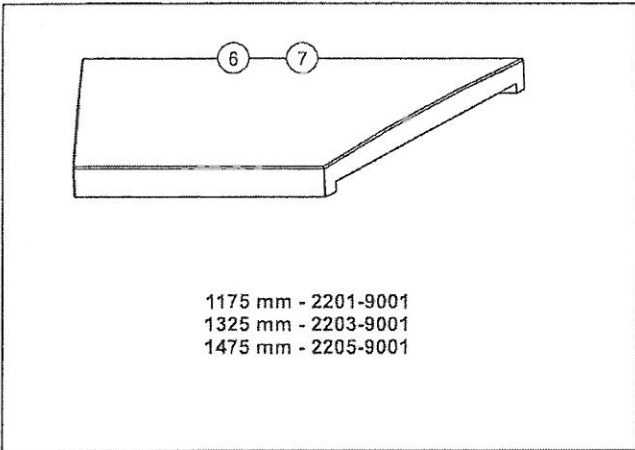
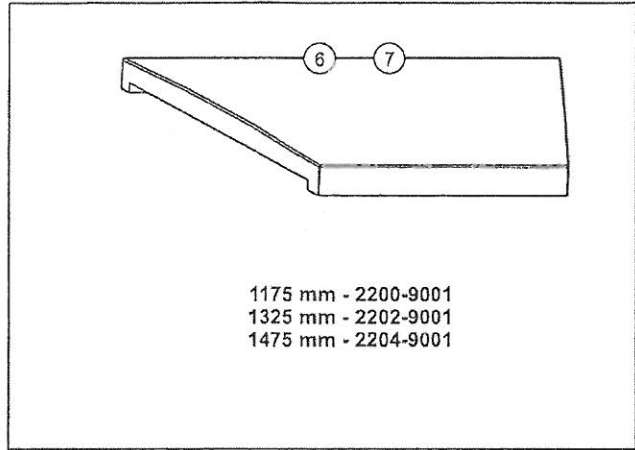
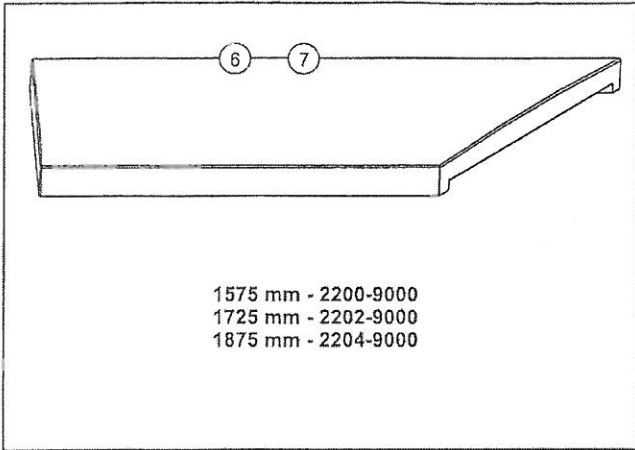

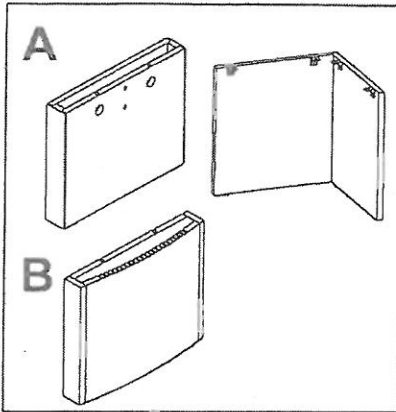

A		B		C		D		E	
2x		4x		4x		5x20 8x		M6x20 4x	
F		G		H		I		J	
8x30 4x		3x		M6x65 4x		4x60 1x		7x50 3x	
K									
1x									

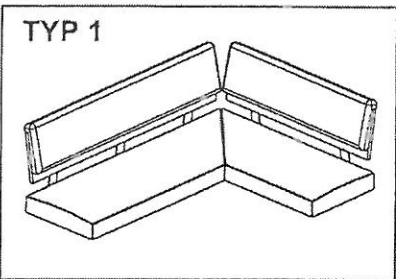

L		M		N		O		E	
5x		M6x50 6x		M6x40 4x		M6x30 10x		M6x20 10x	
Q		R		S		I		T	
6x		6x		4x16 12x		4x60 1x		840 1x	

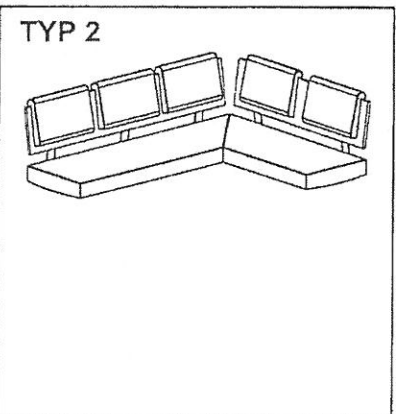

L		M		N		O		E	
5x		M6x50 6x		M6x40 4x		M6x30 10x		M6x20 10x	
Q		R		S		I		T	
10x		10x		4x16 20x		4x60 1x		840 1x	
U									
10x									

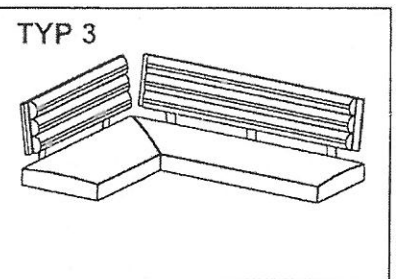

L		M		N		O		P	
5x		M6x50 6x		M6x40 4x		M6x30 10x		M6x40 10x	
I		T							
4x60 1x		840 1x							

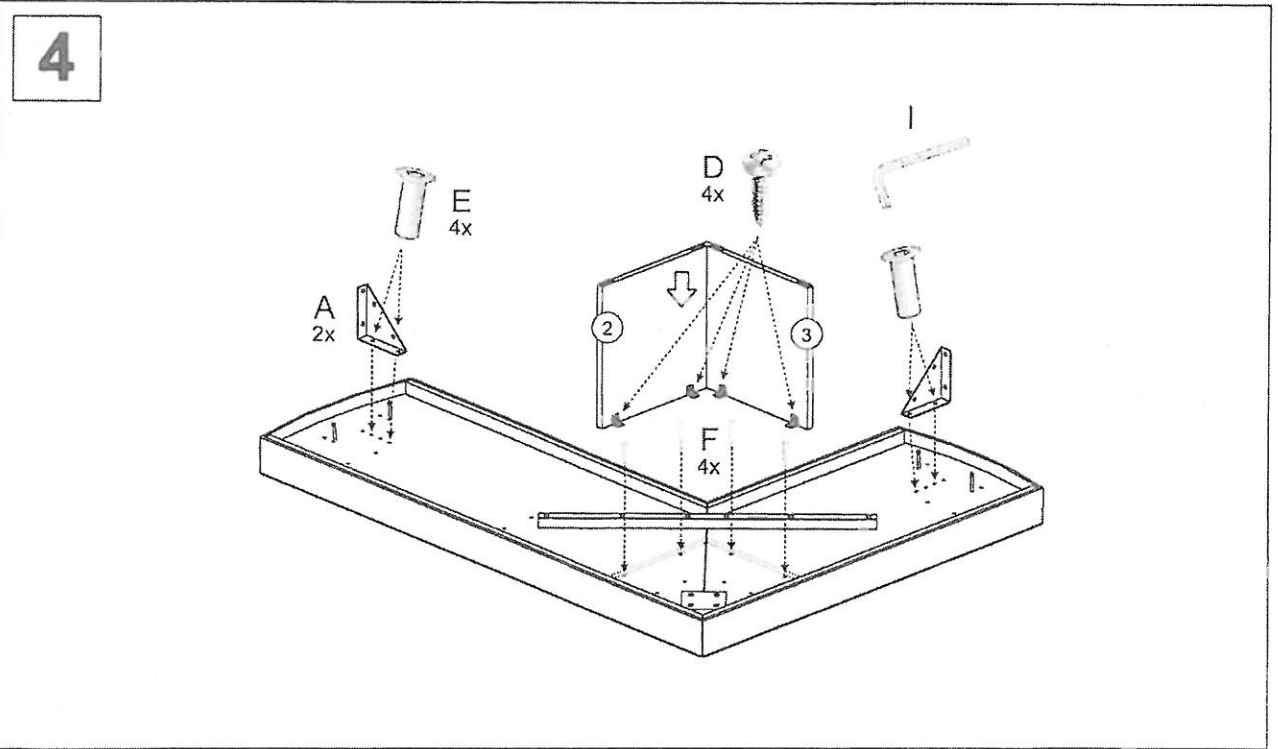
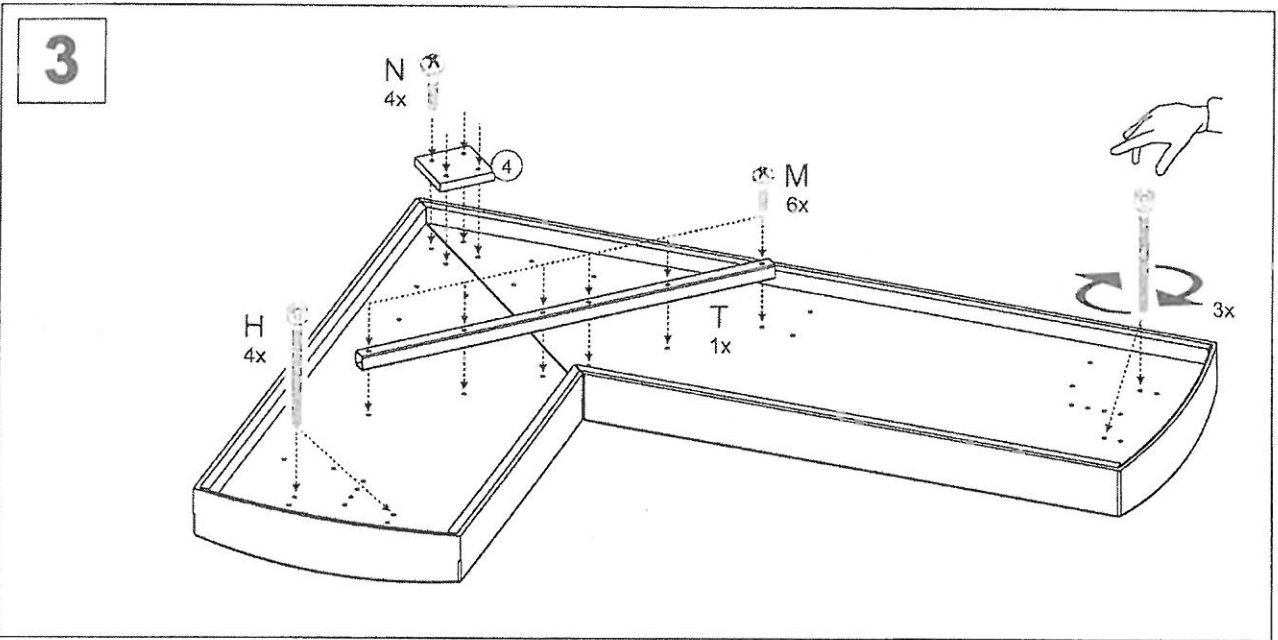
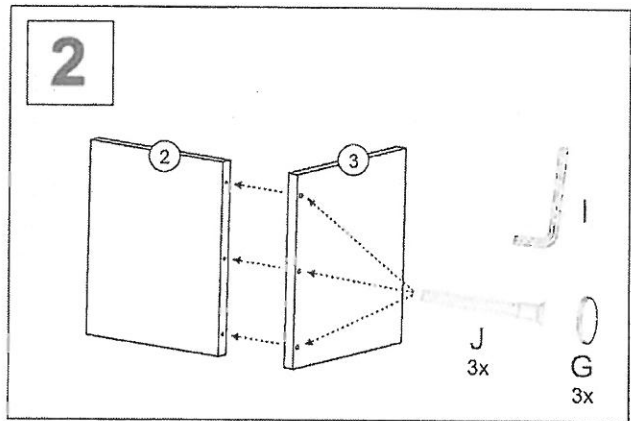
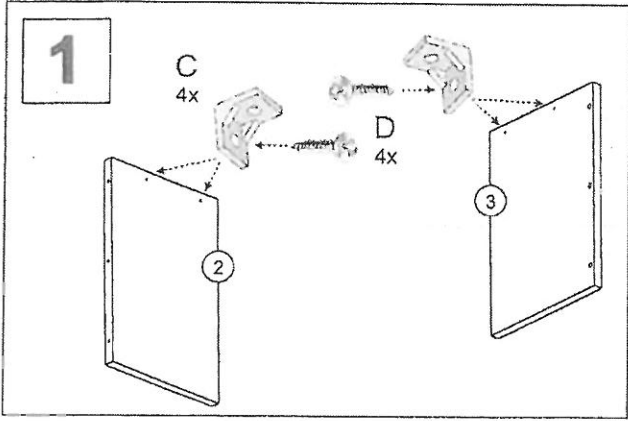

5

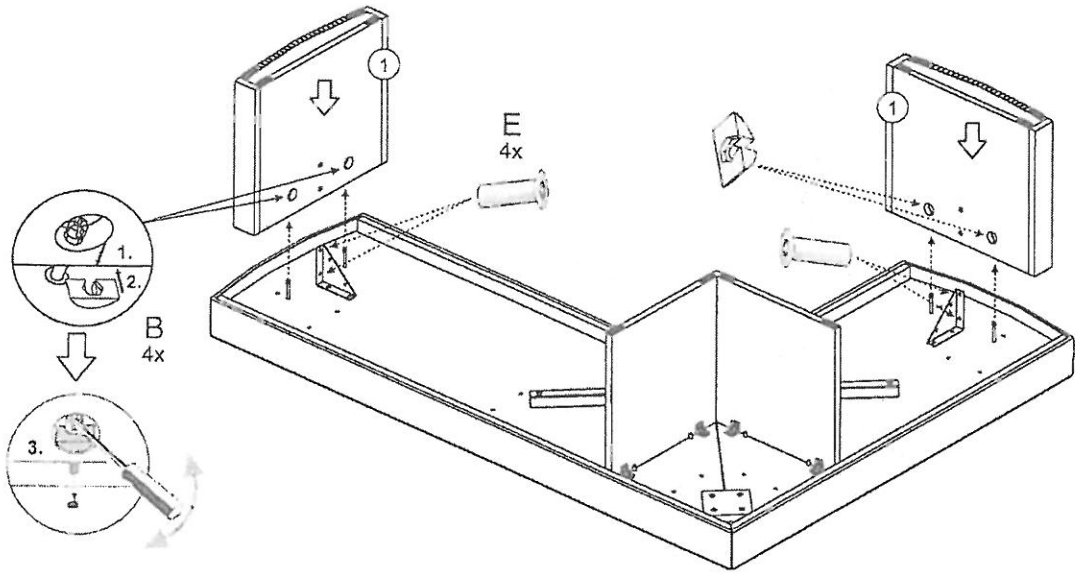

6

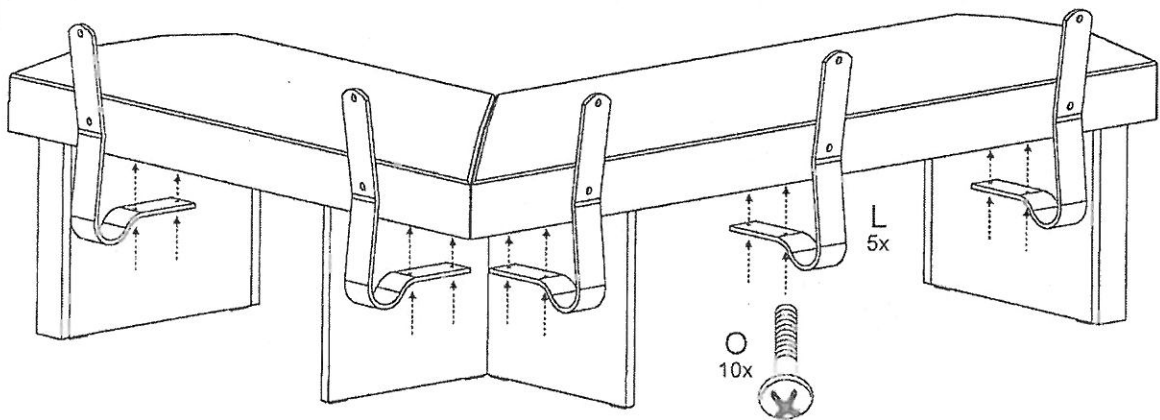

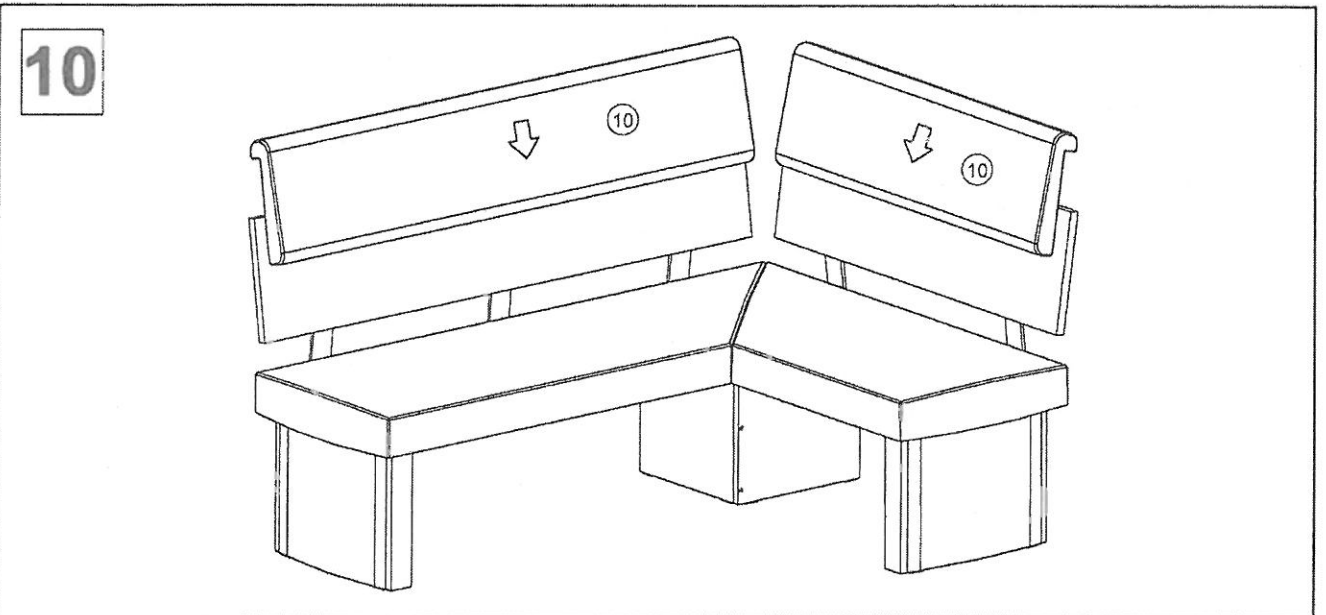
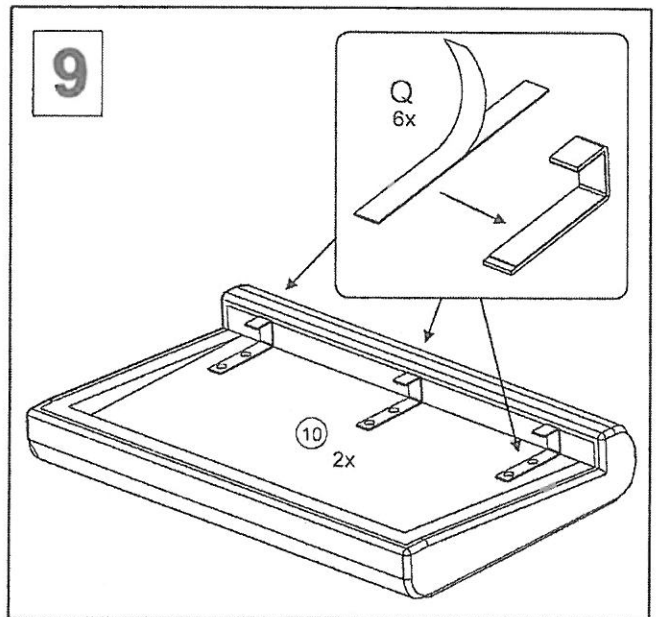
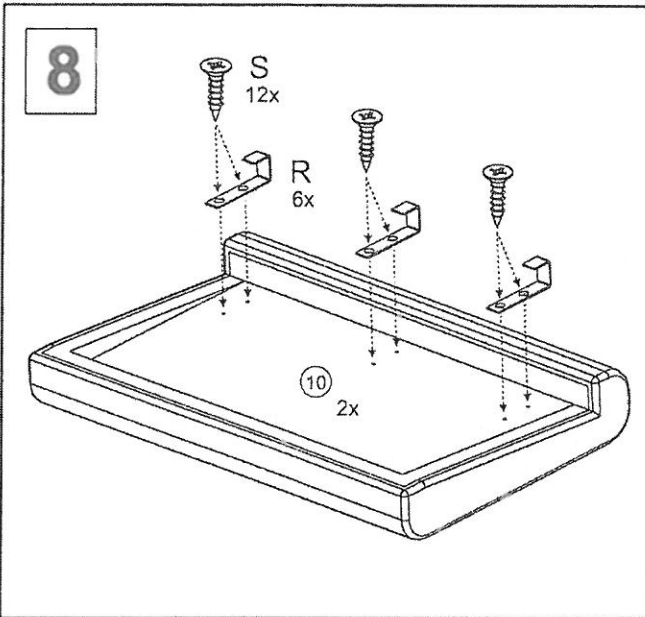
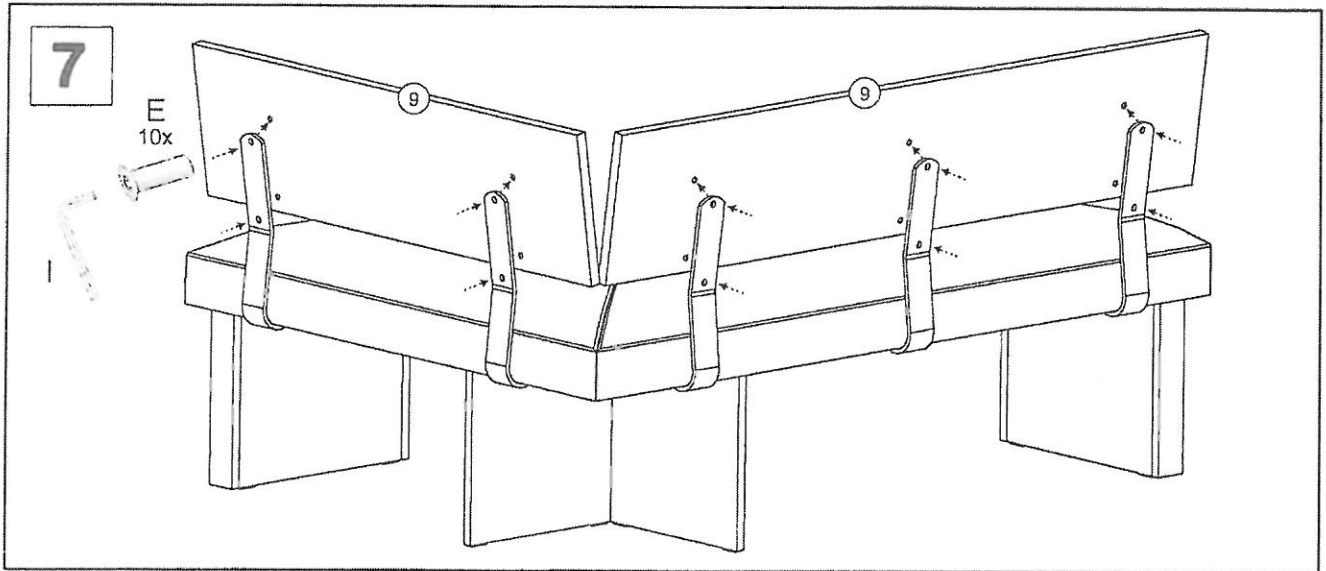

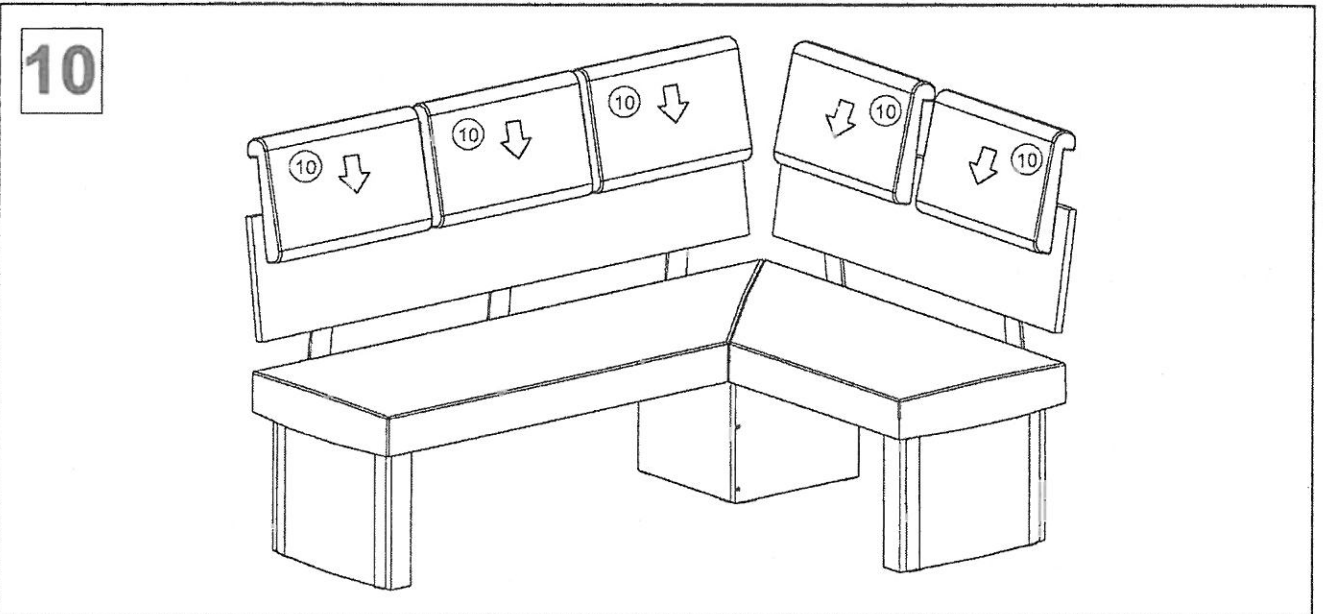
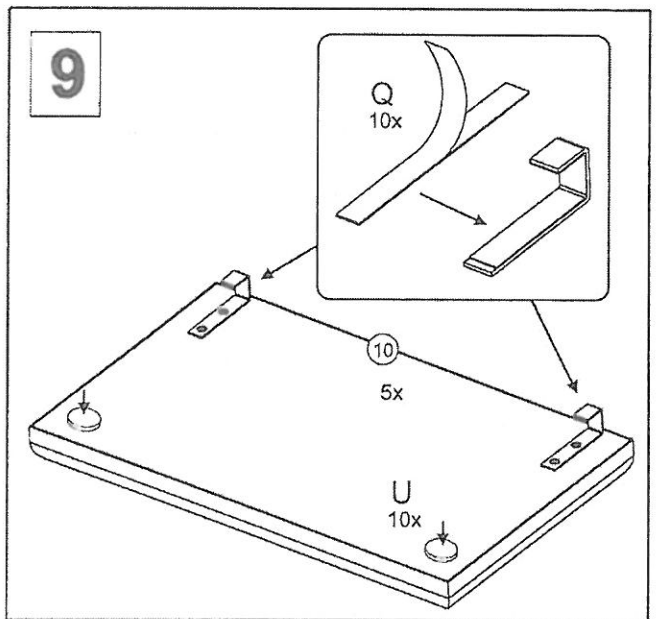
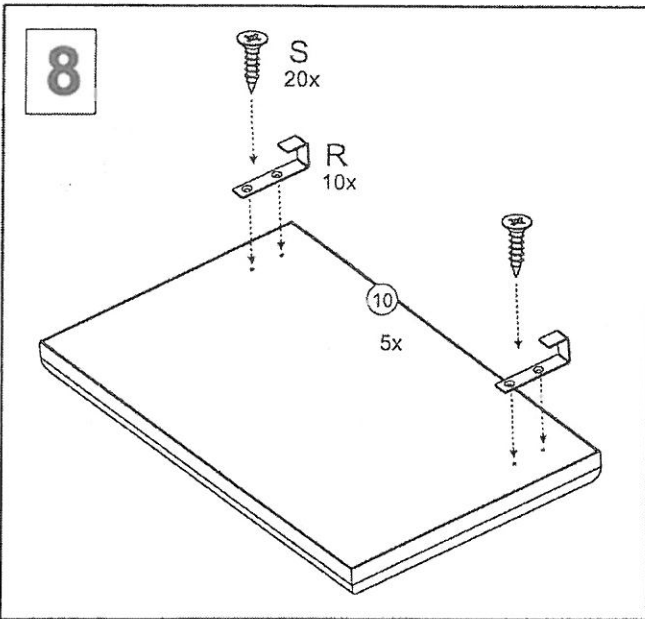
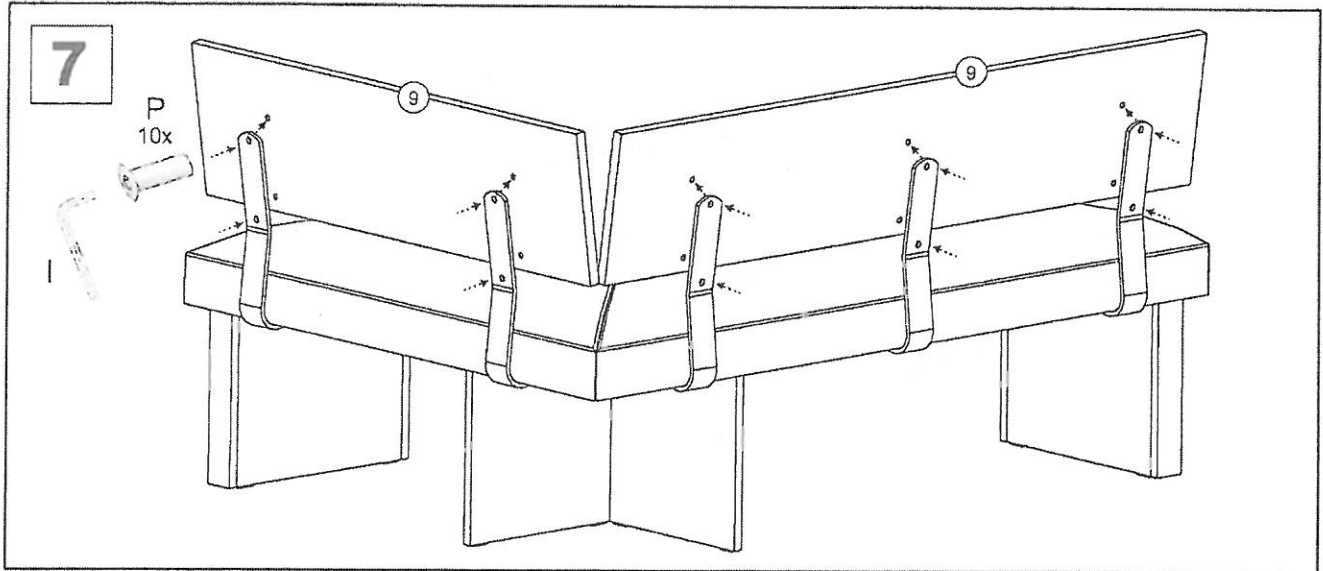

7

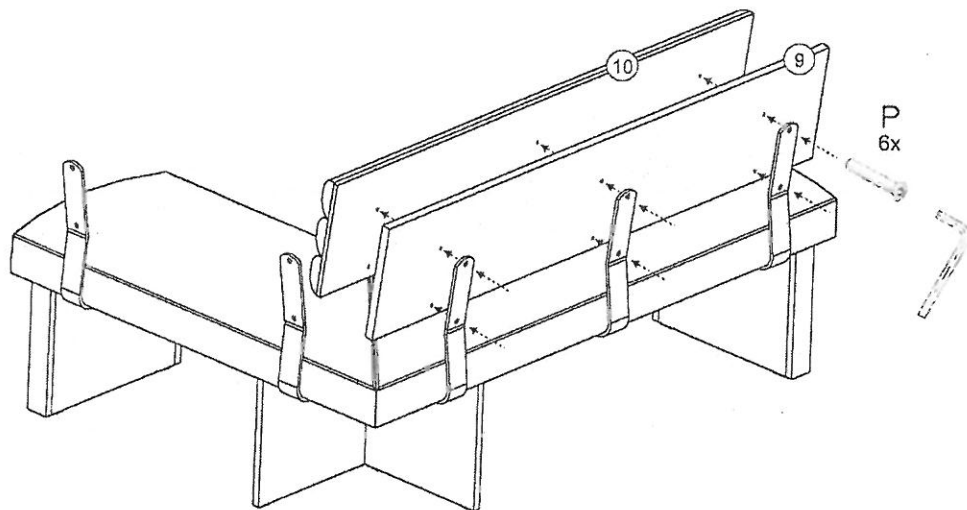

8

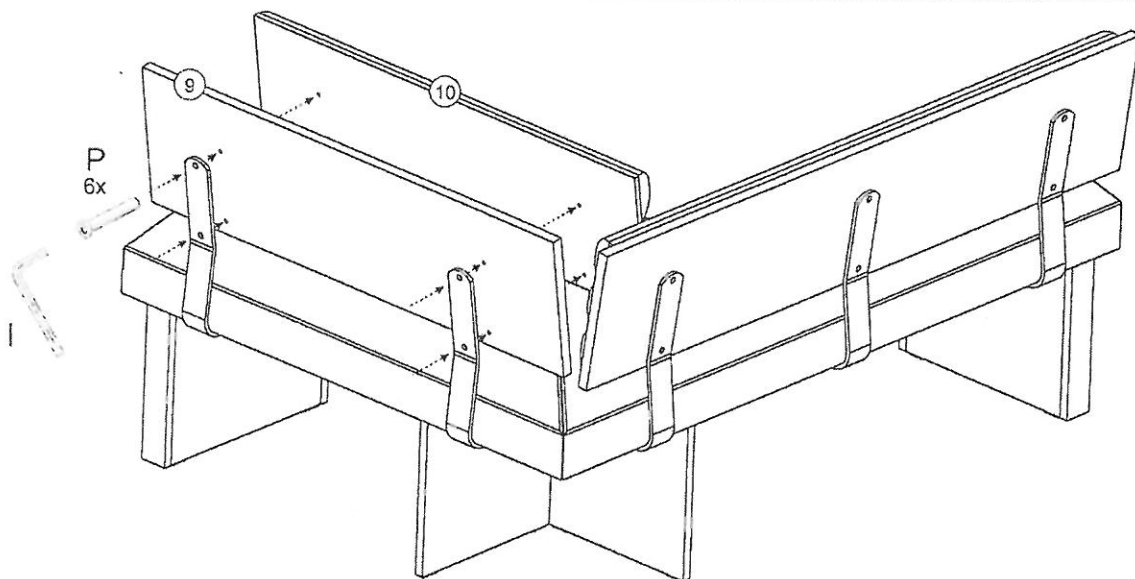

9

