

1.

M1 423\_06

rauch

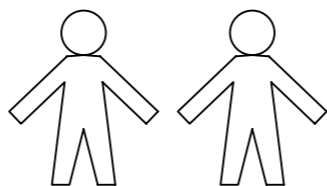
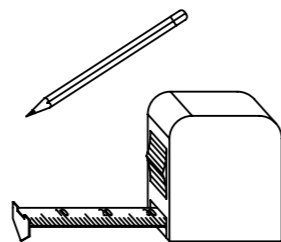
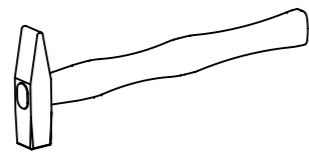
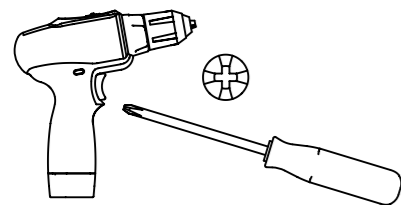

Typ I

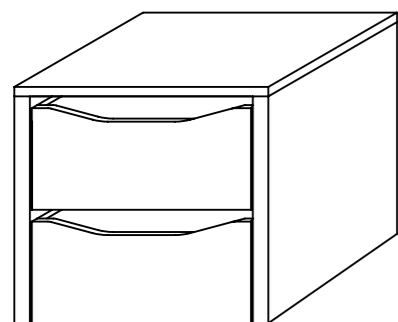
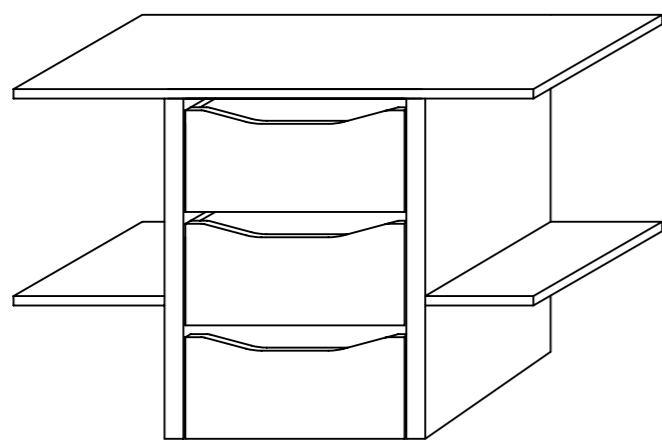

Typ II

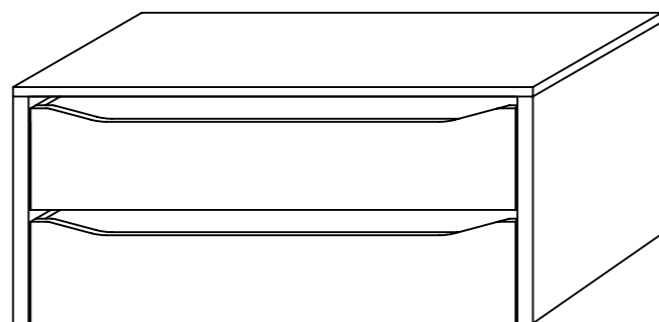

Typ III

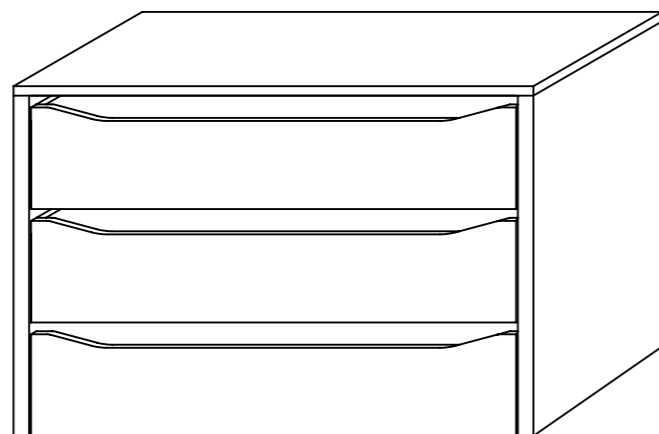
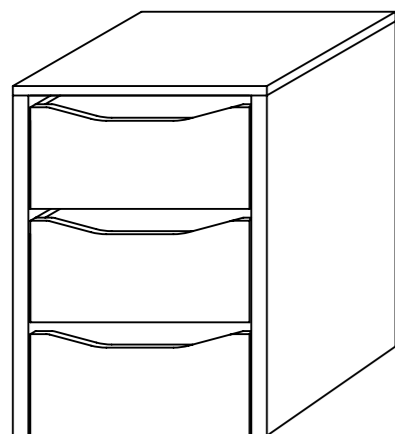

2.

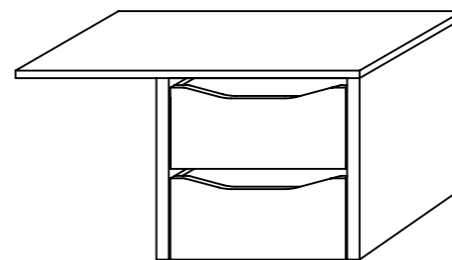

Typ IV

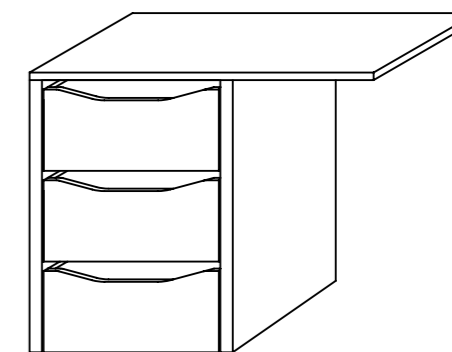
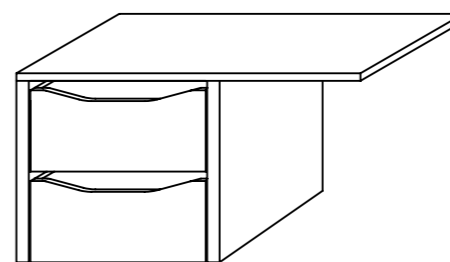
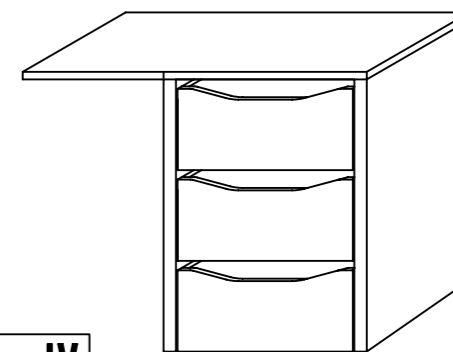

Typ V

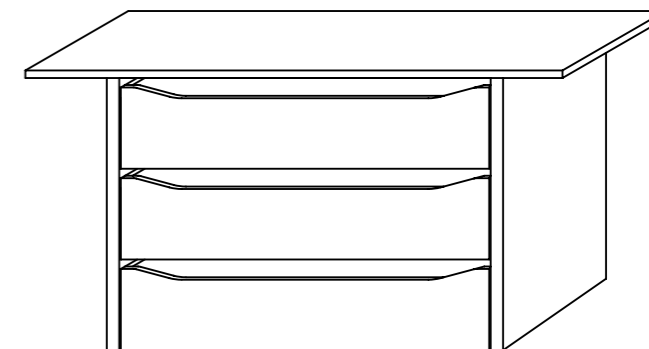
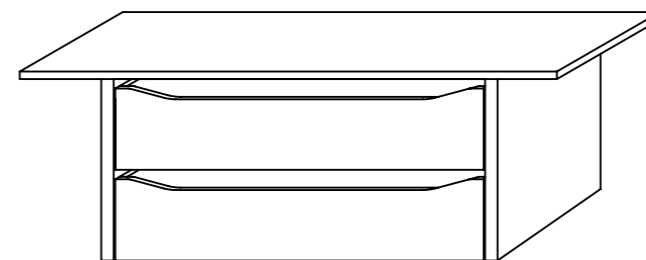

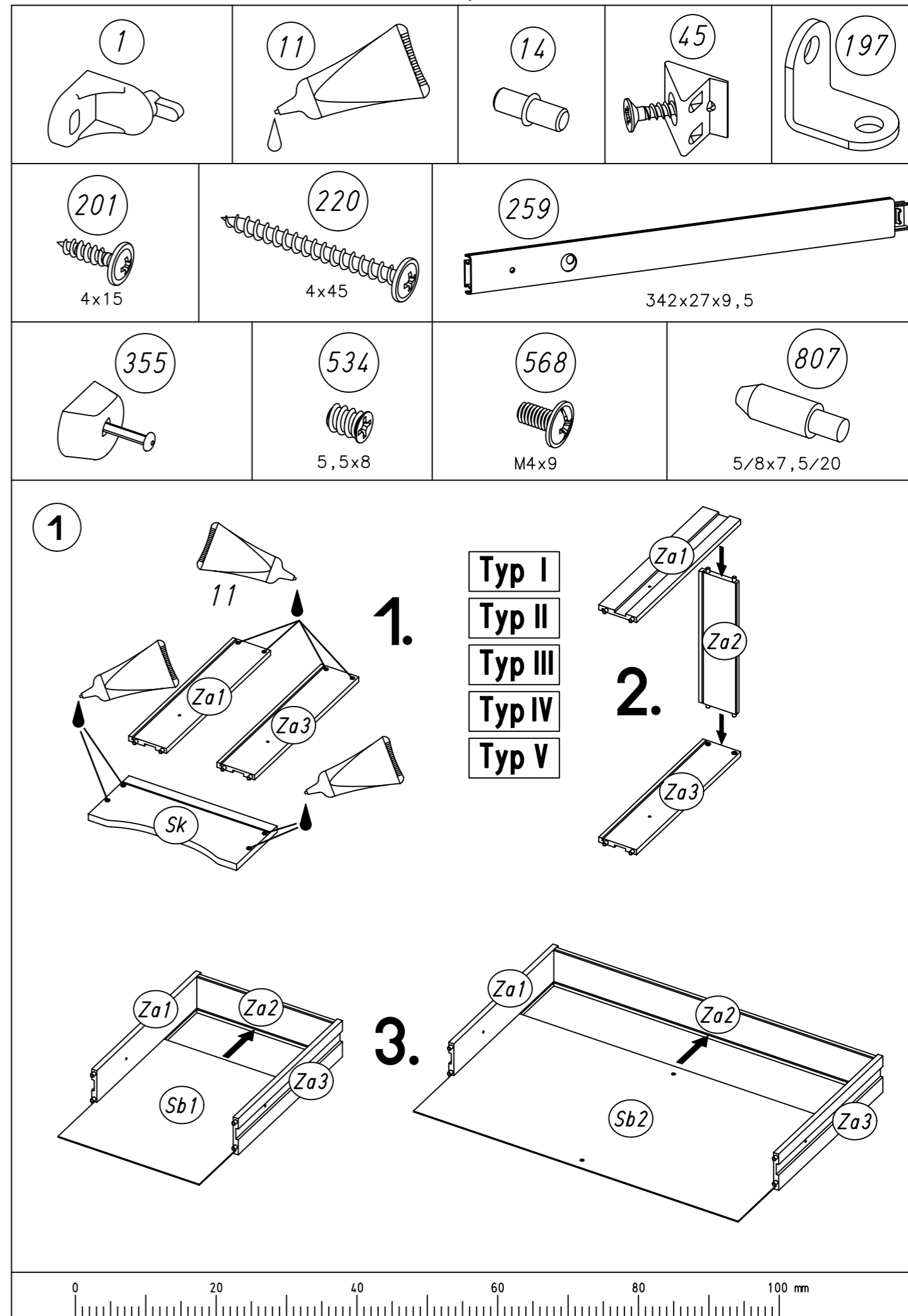
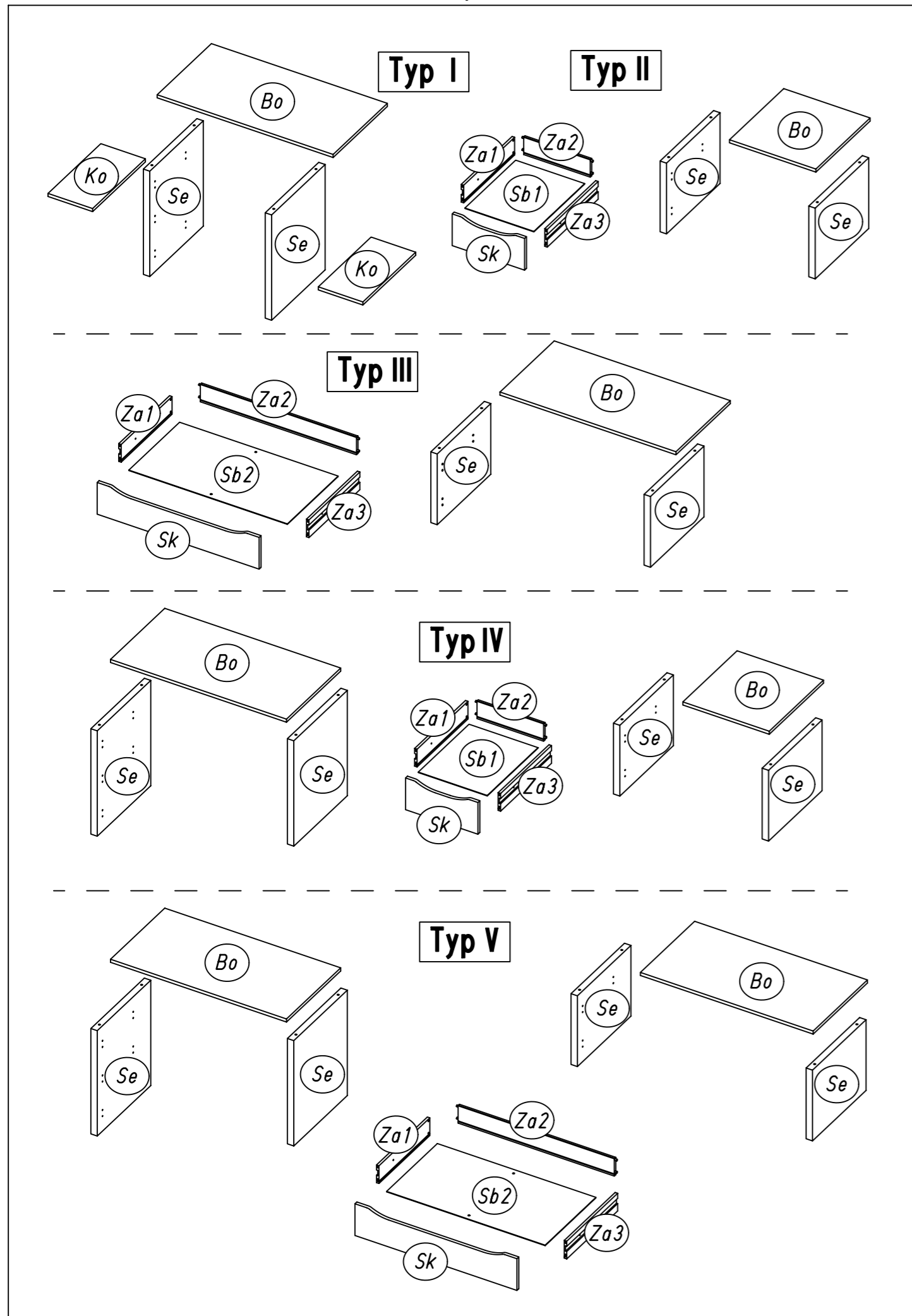

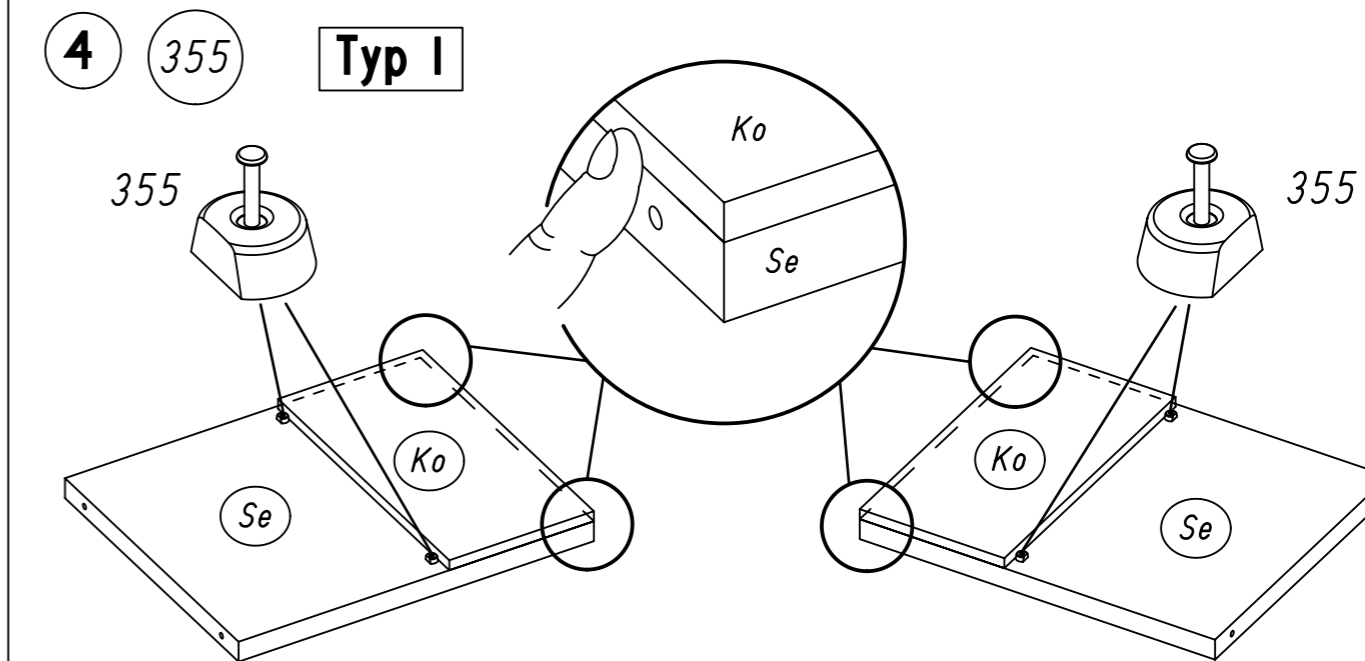
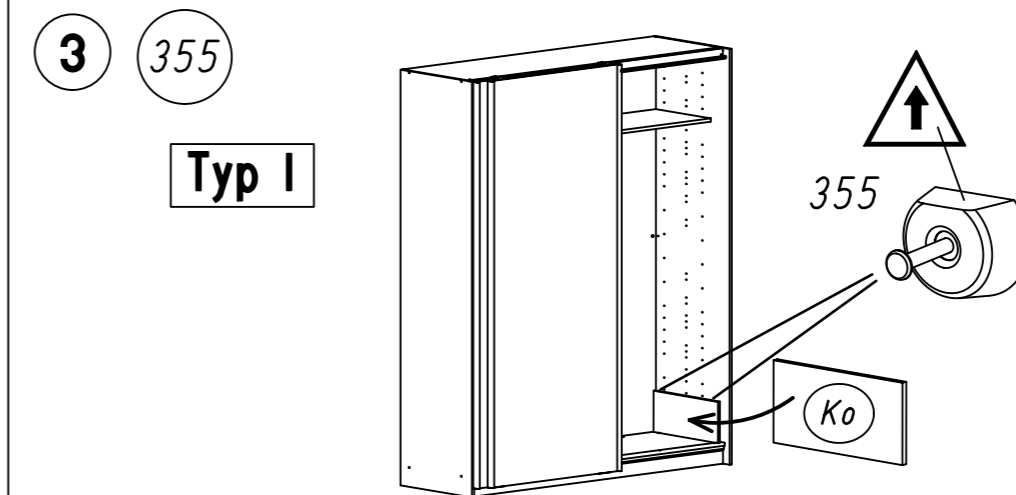
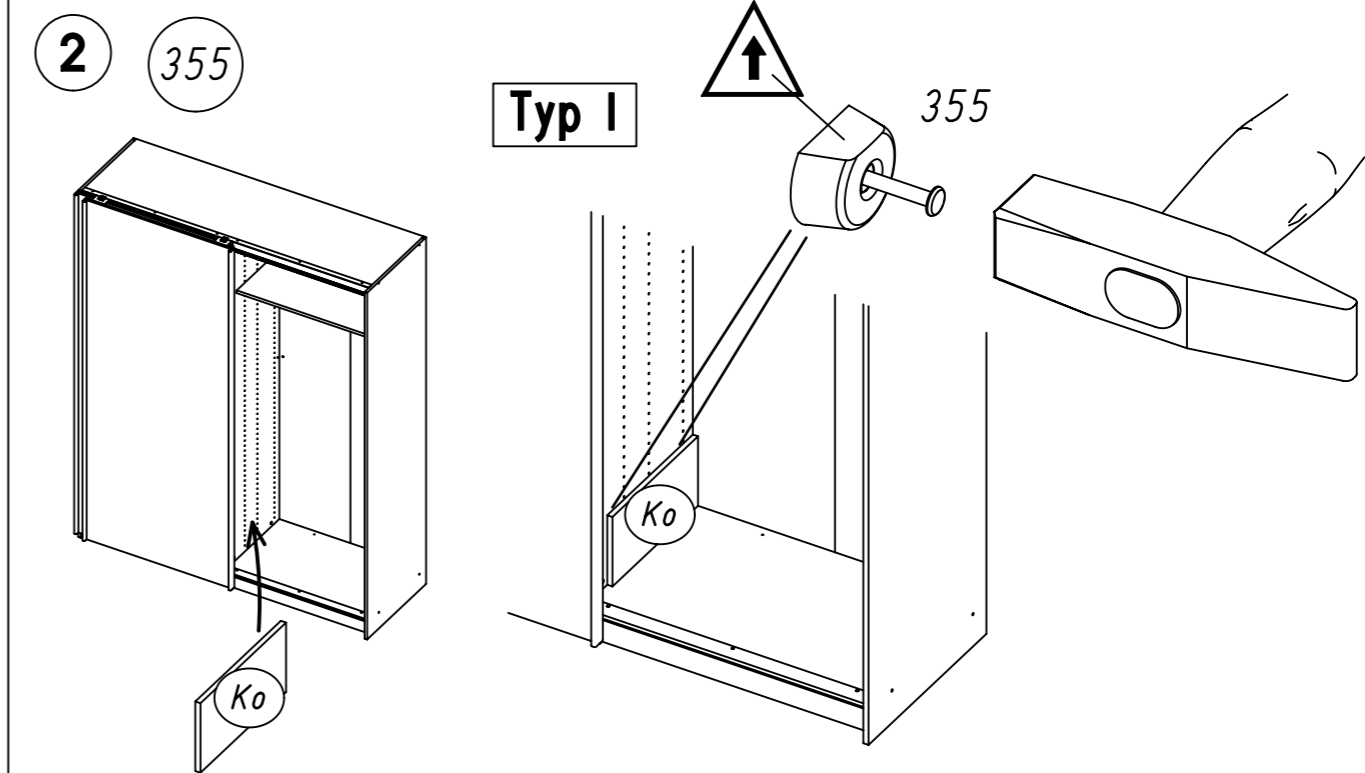
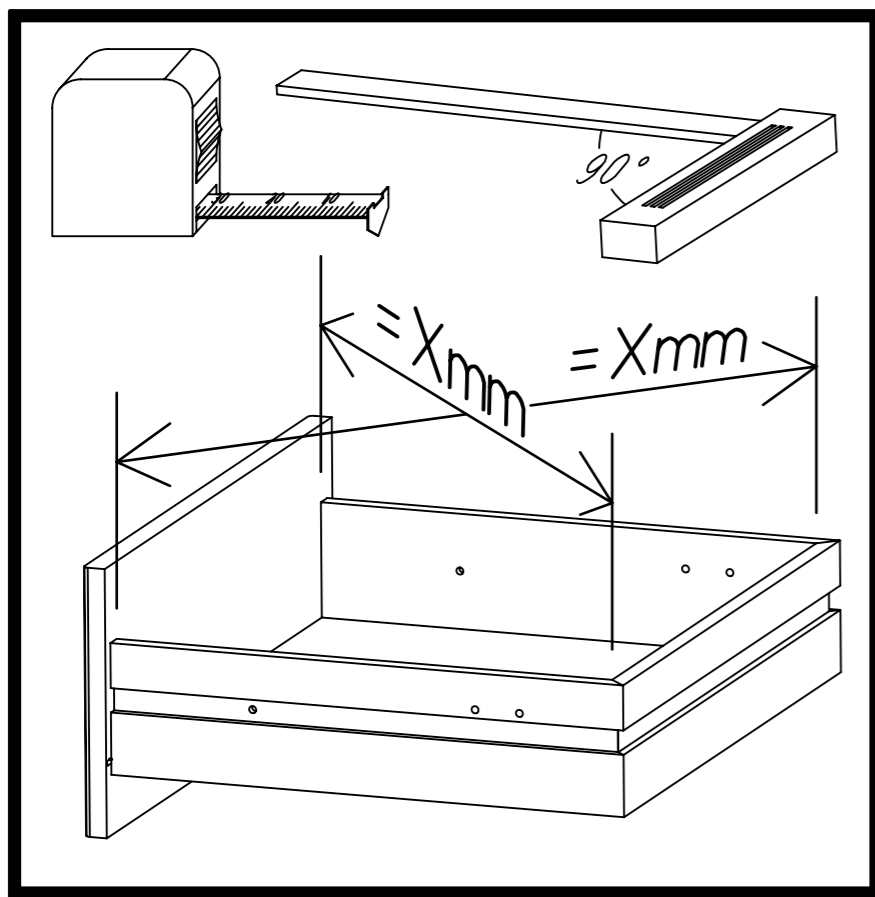
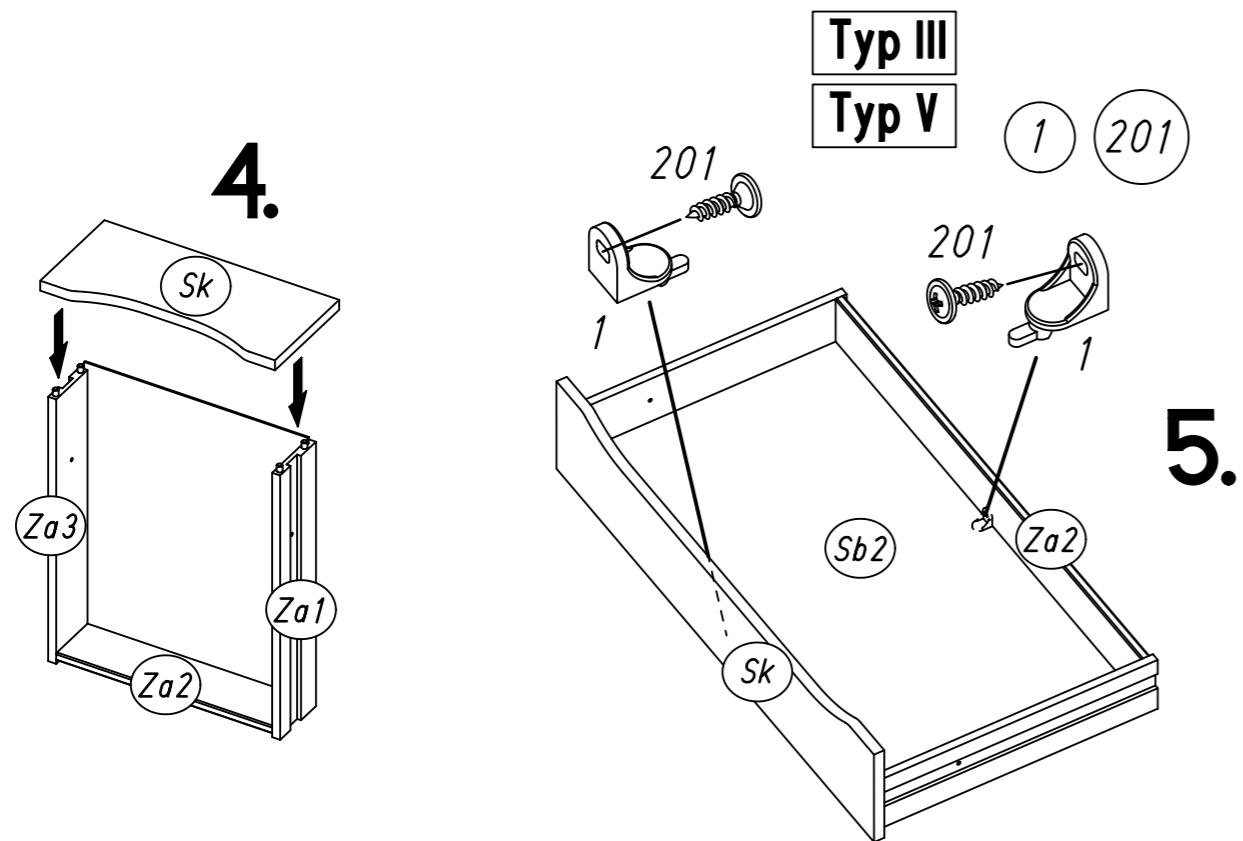

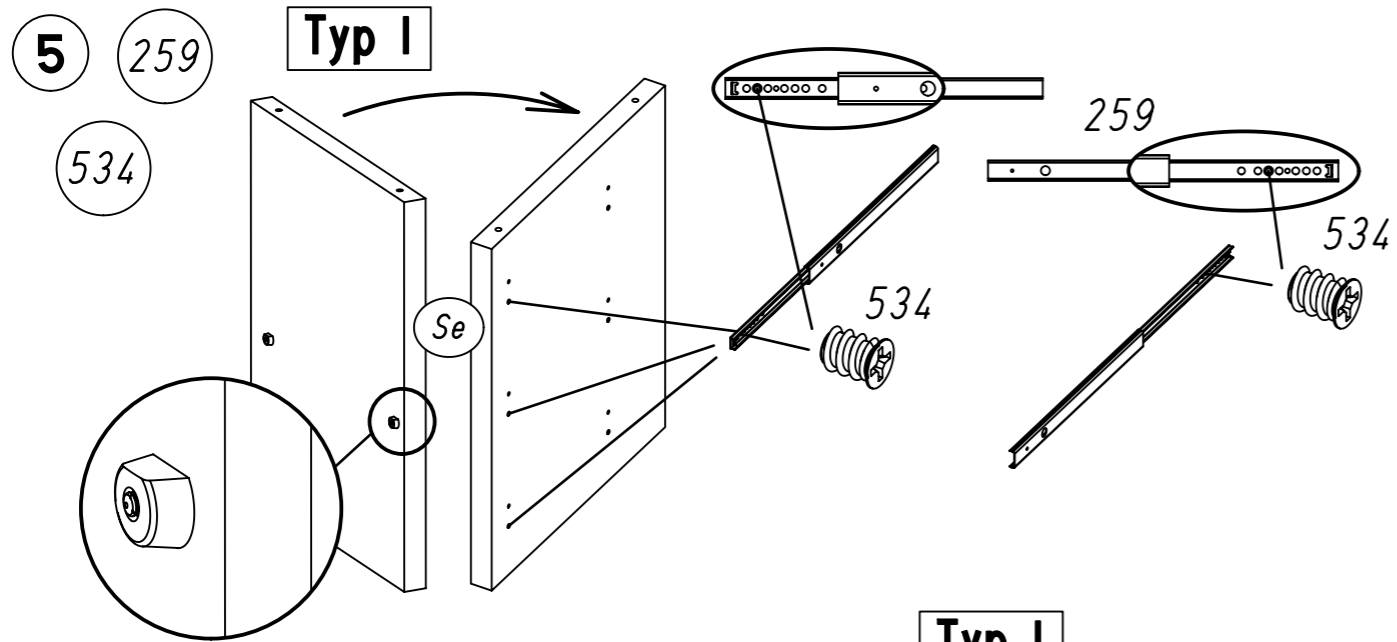

Typ I

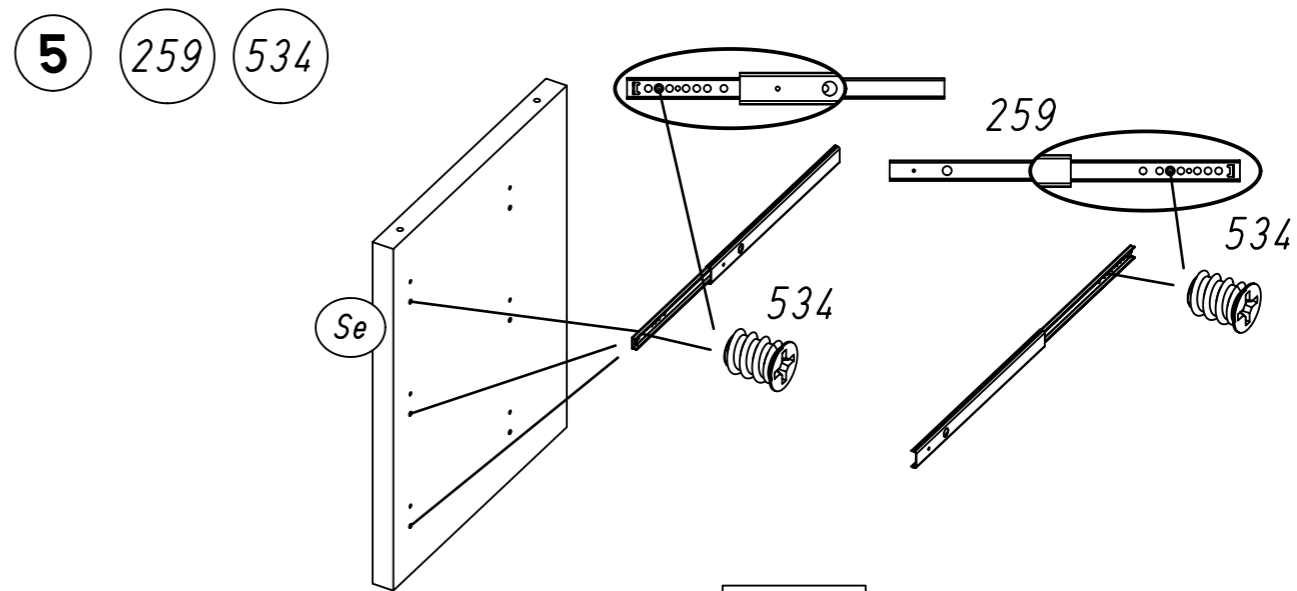
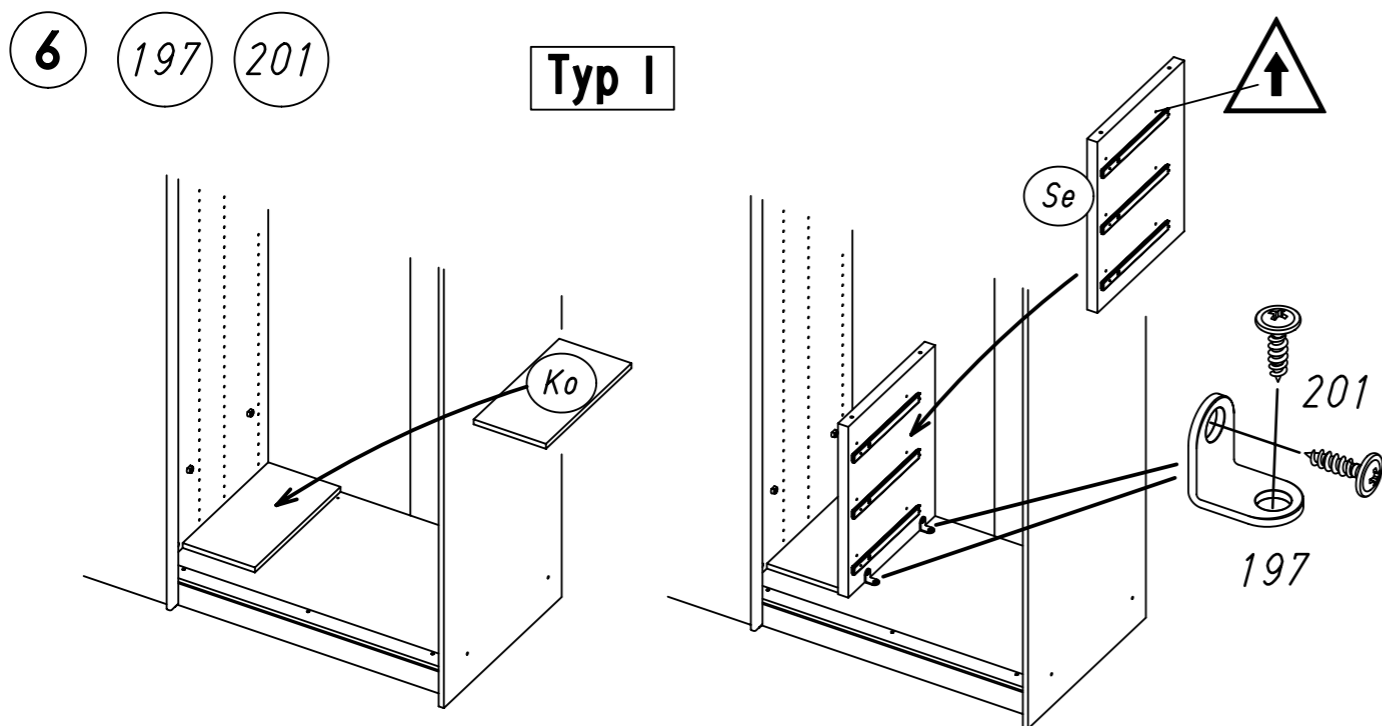
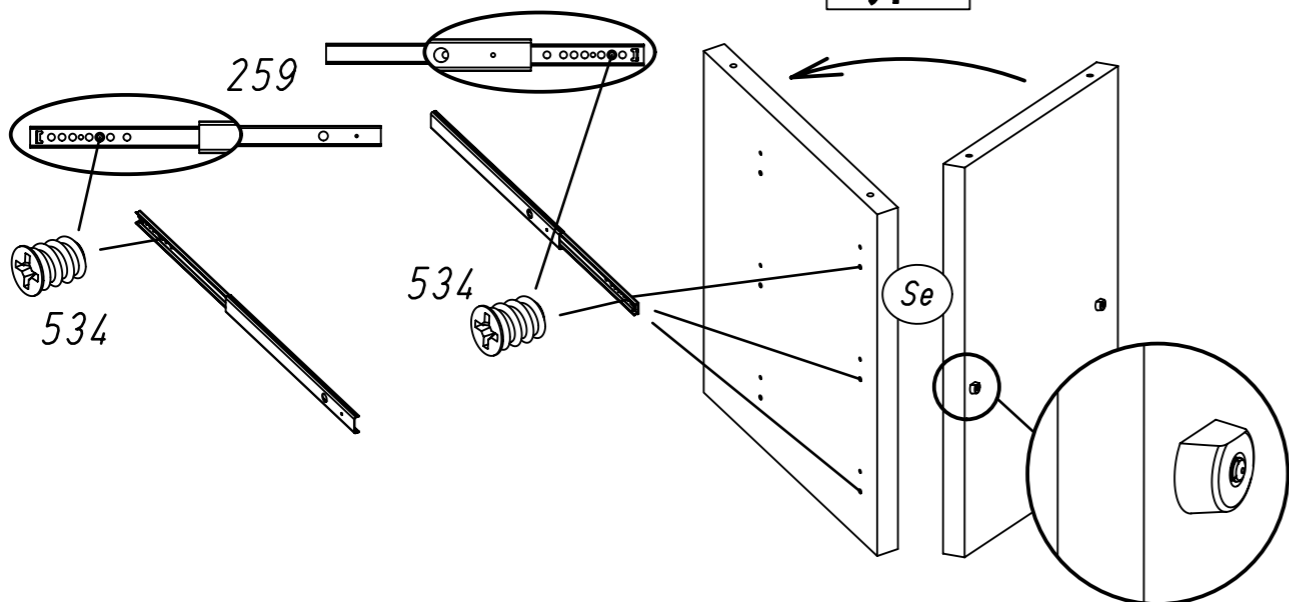

Typ V

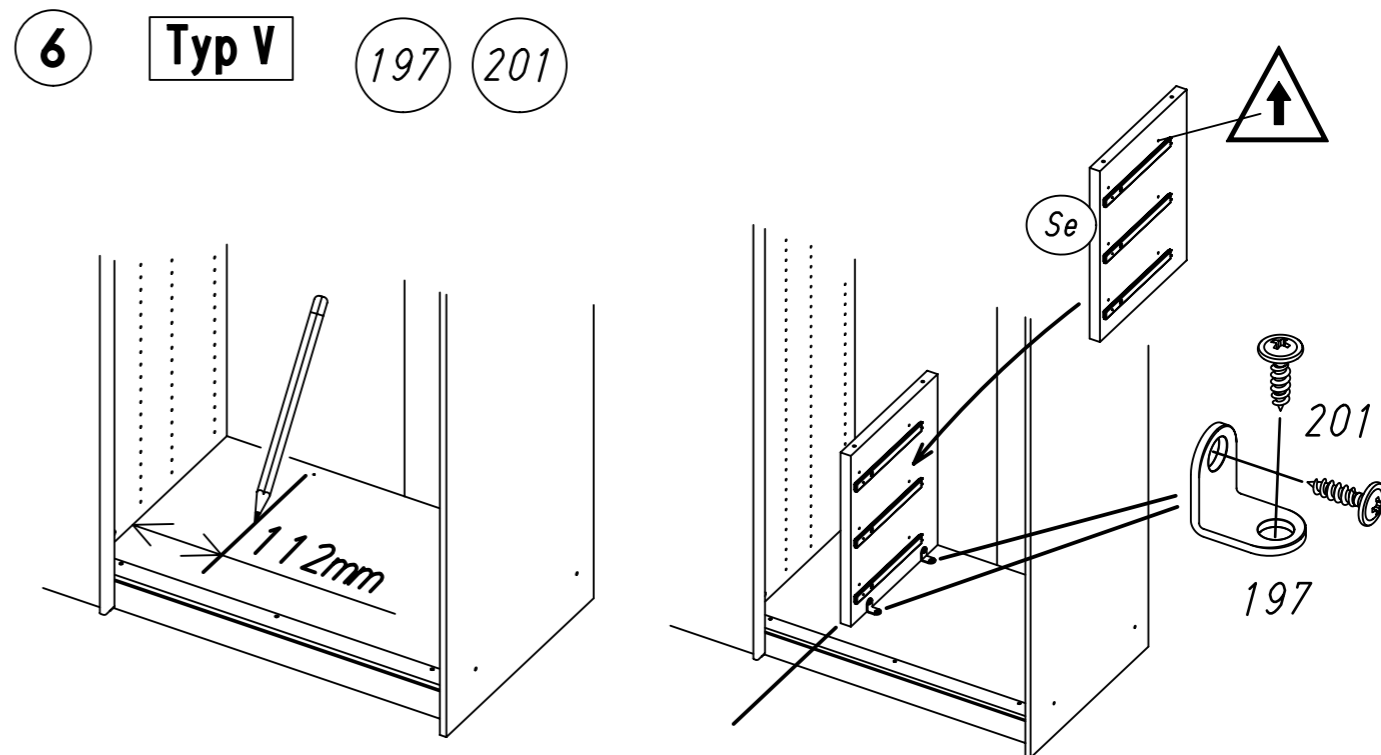
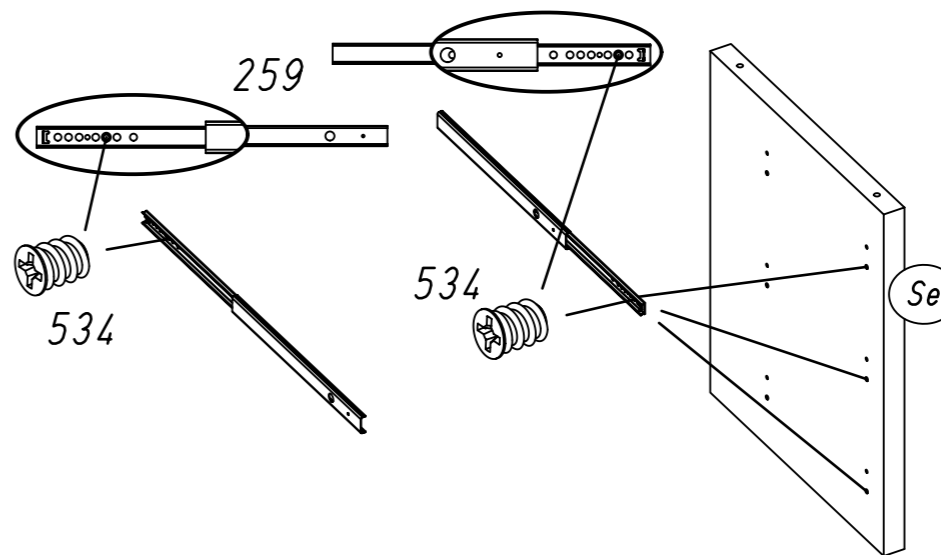

7 197 201 Typ I

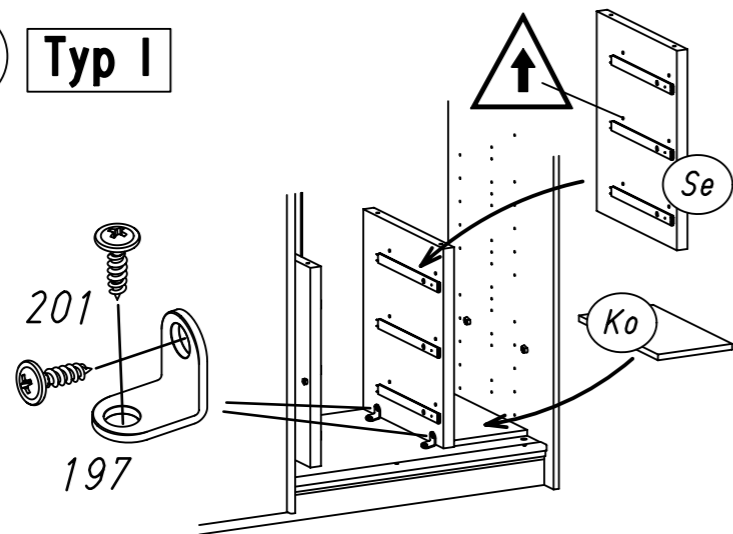

8 807 Typ I

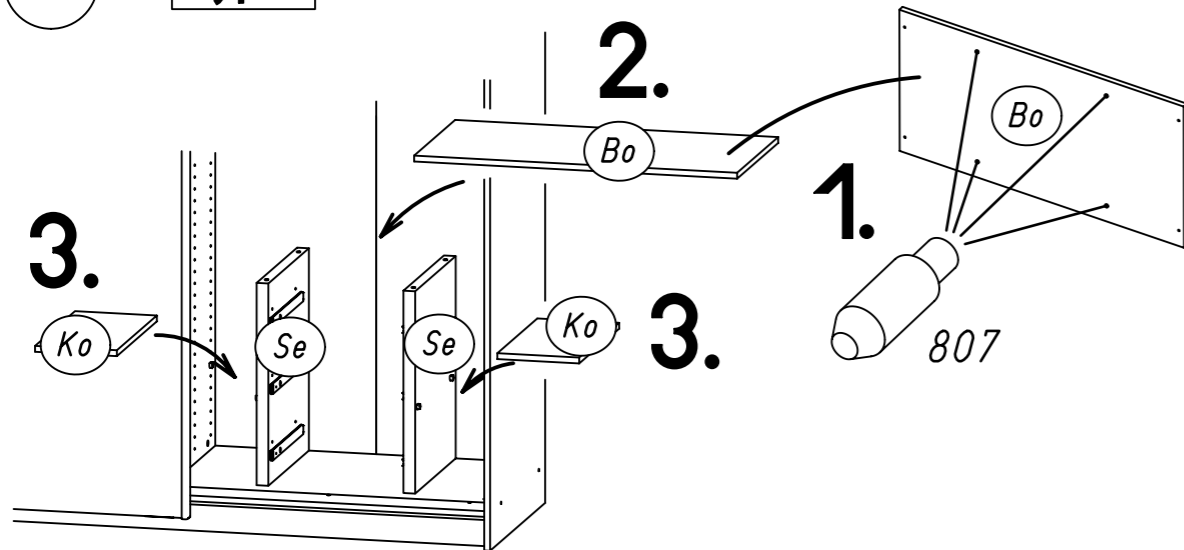

7 197 201 Typ V

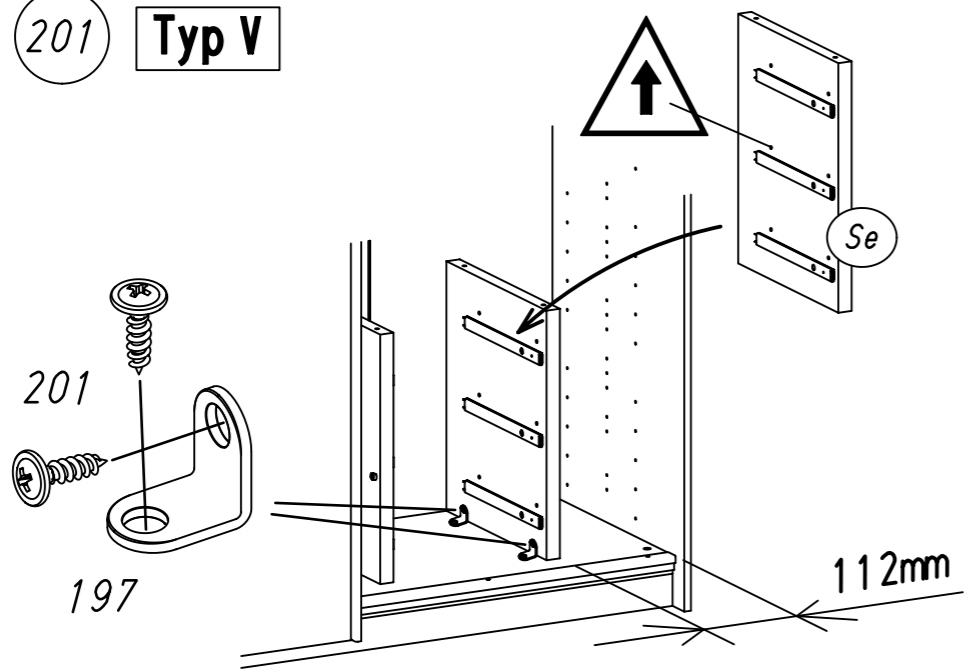

8 807 Typ V

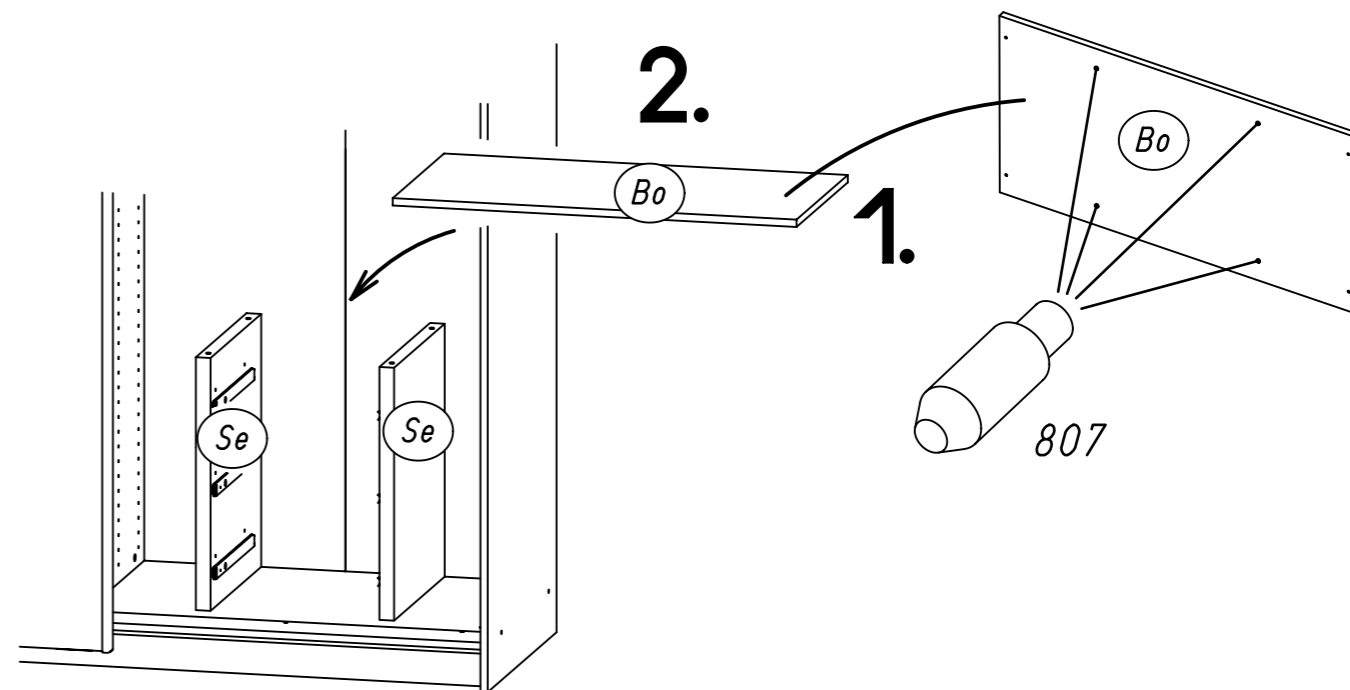

9 568 Typ I Typ V

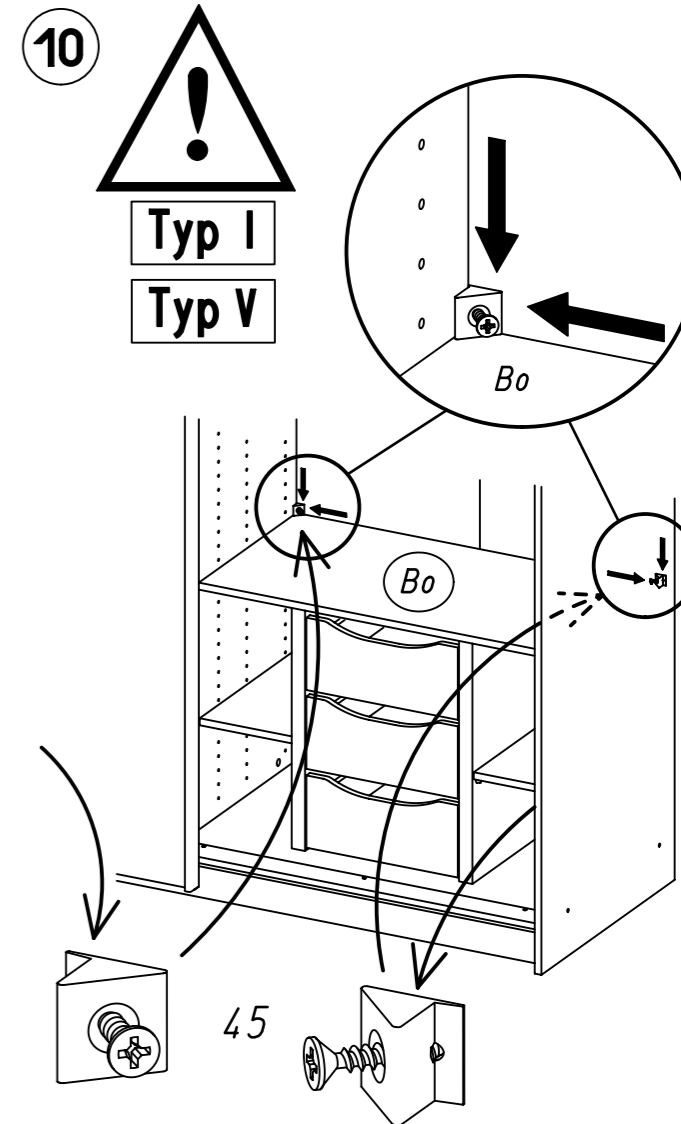
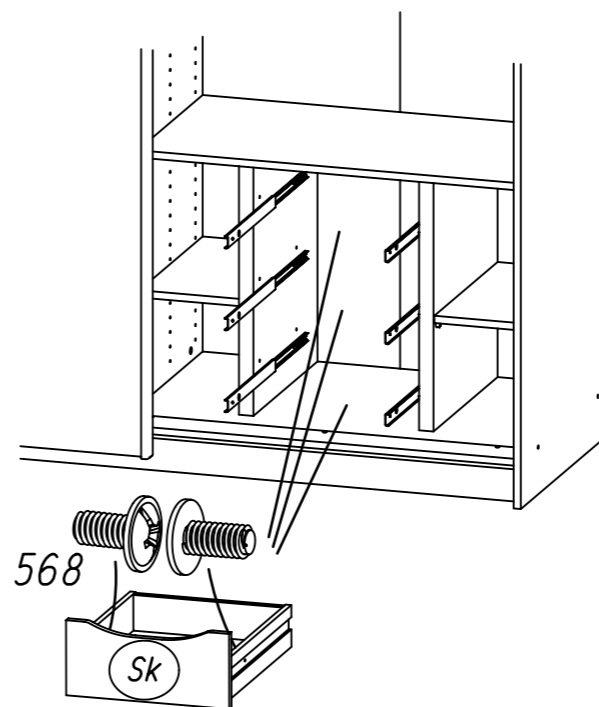

Typ II Typ III

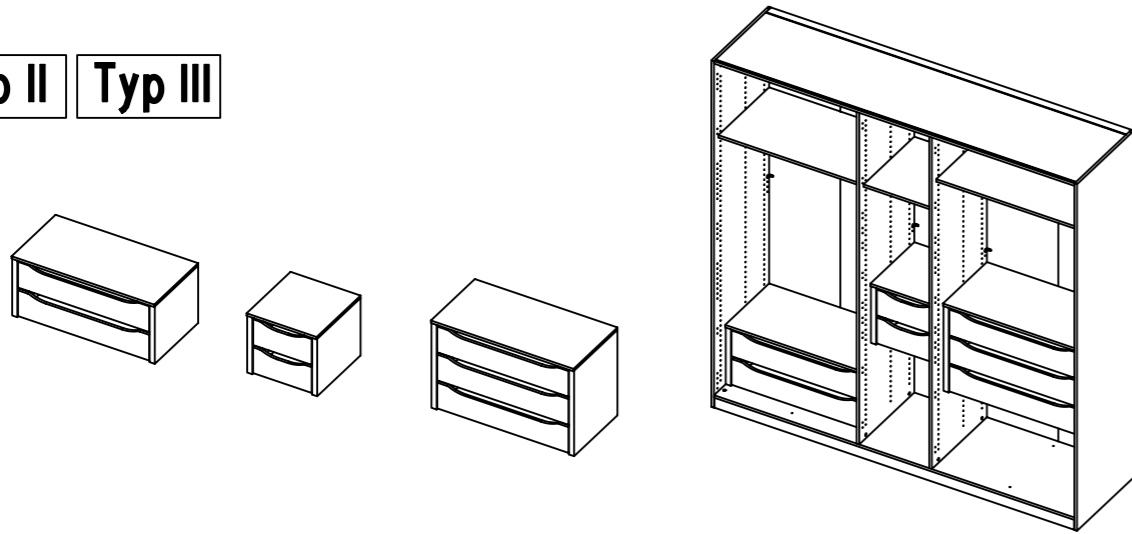

1 259 534

Typ II Typ III

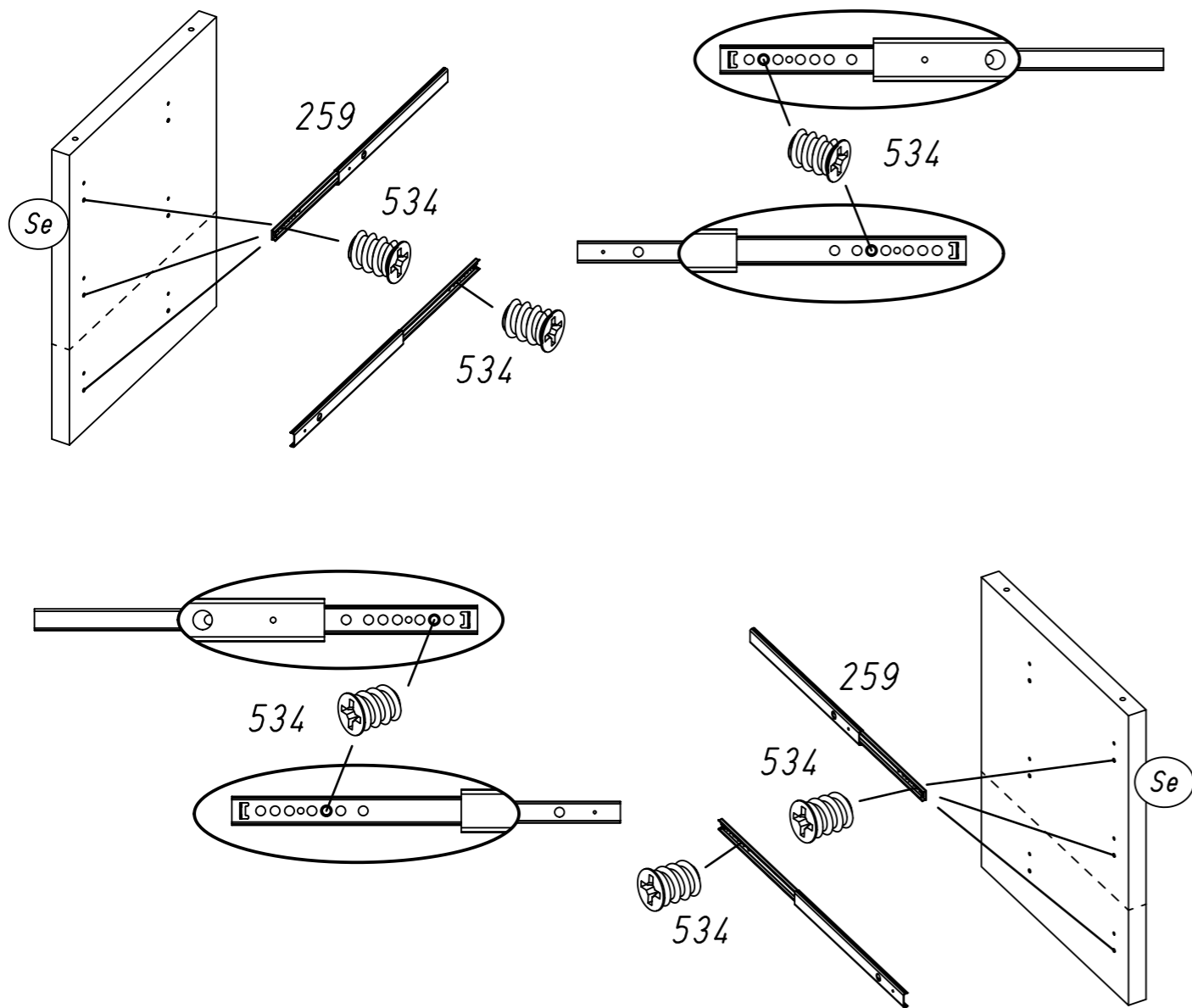

2 14

Typ II  
Typ III

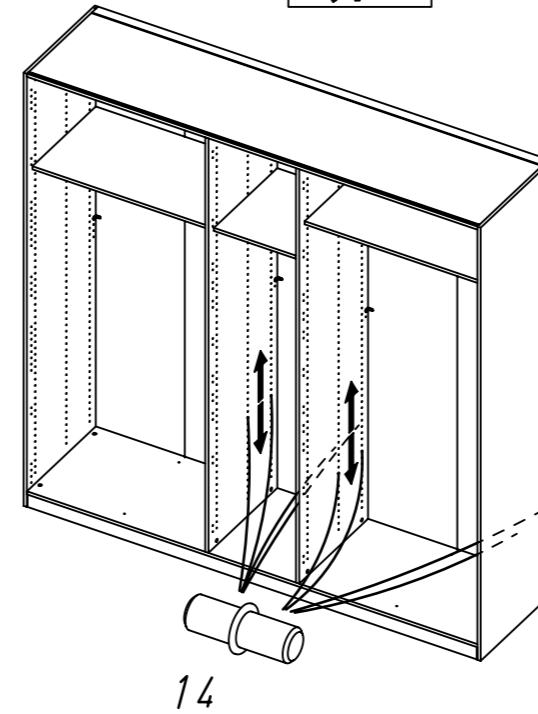

3 220

Typ II  
Typ III

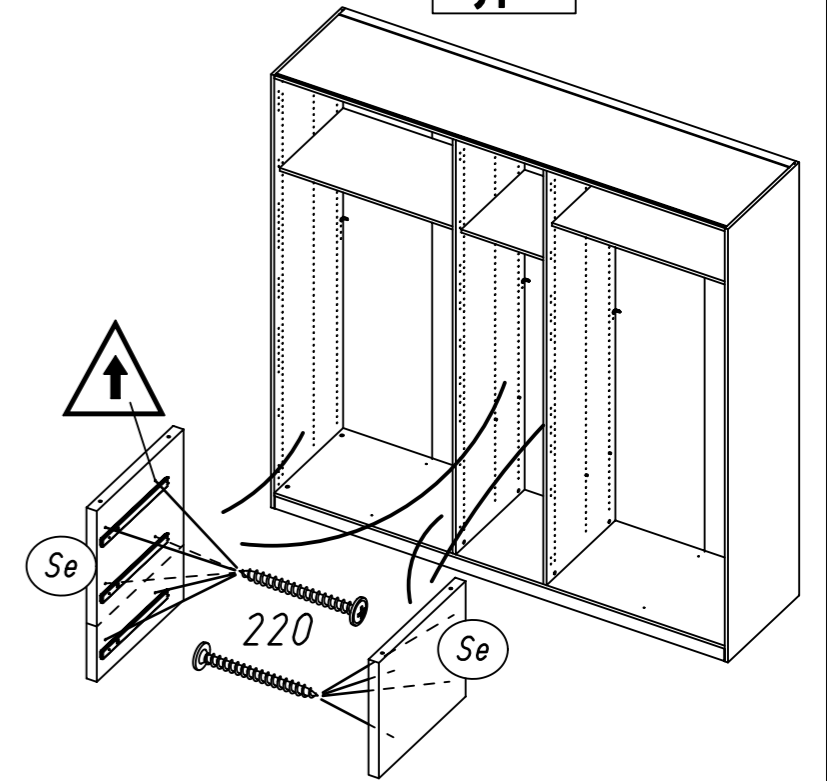

4 807 568

Typ II Typ III

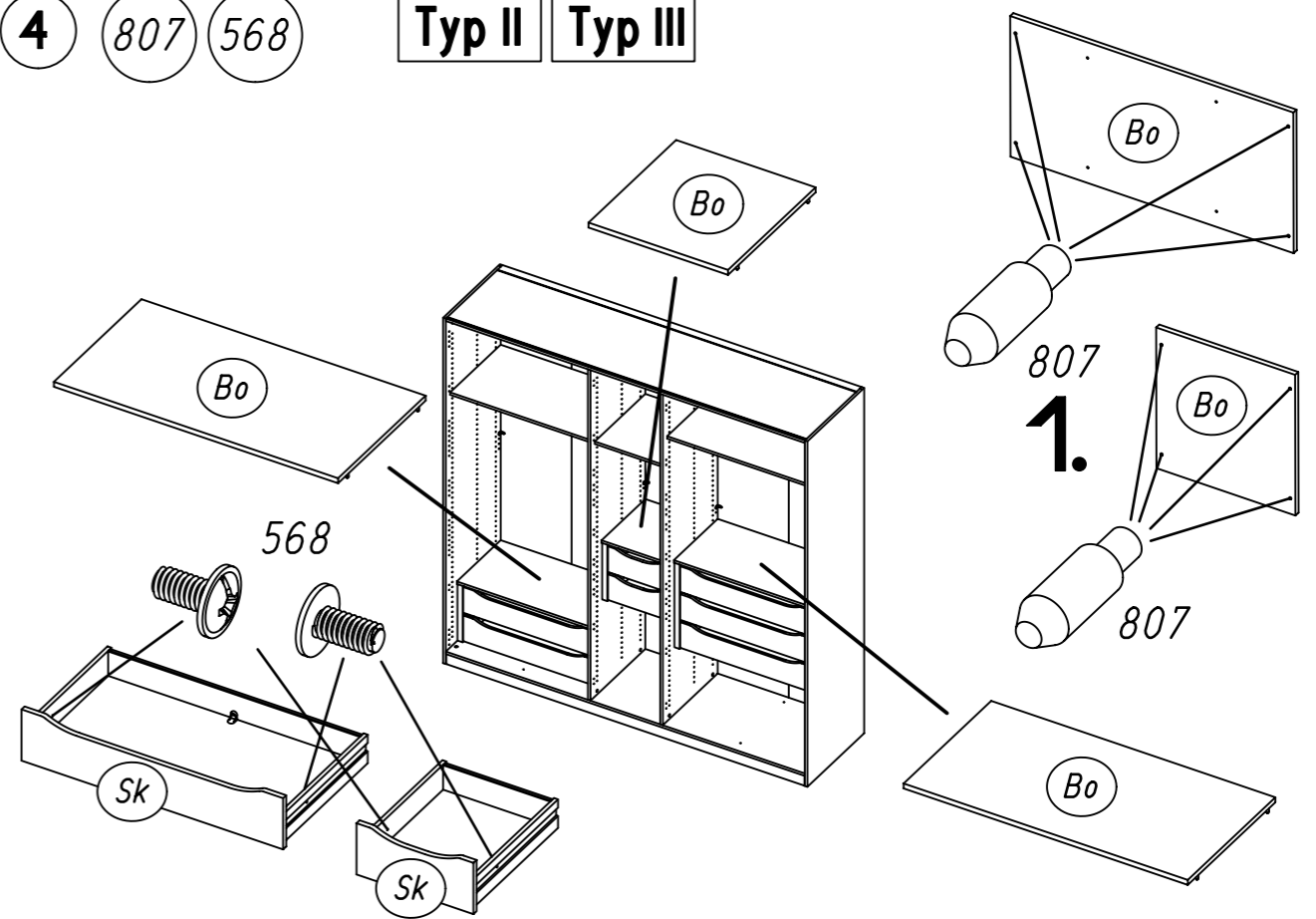

Typ IV

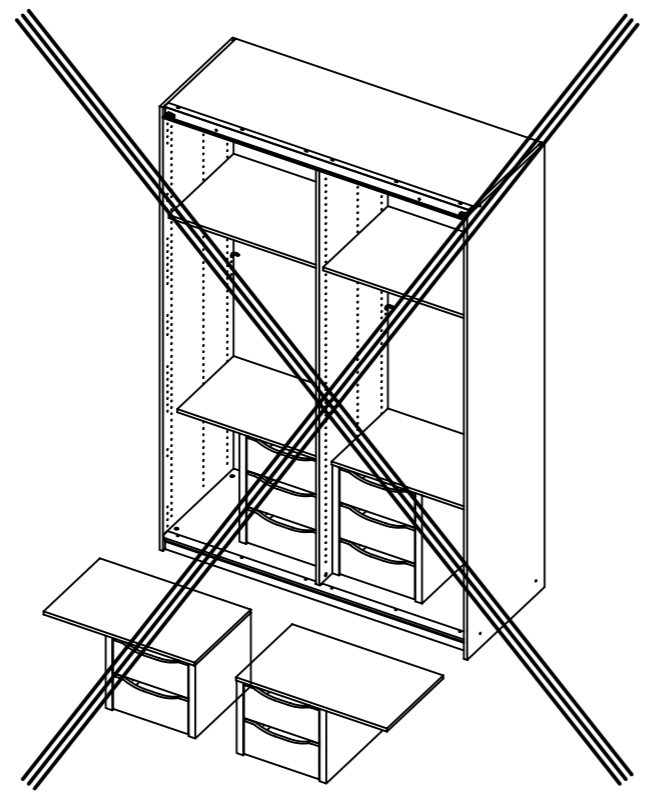
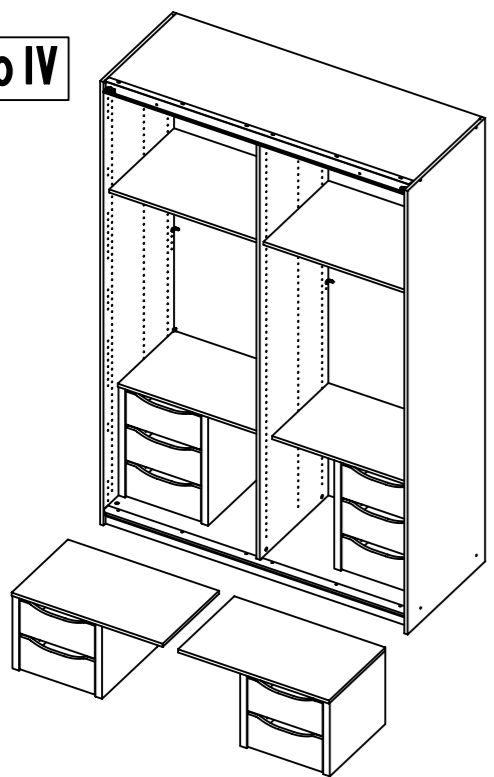

1

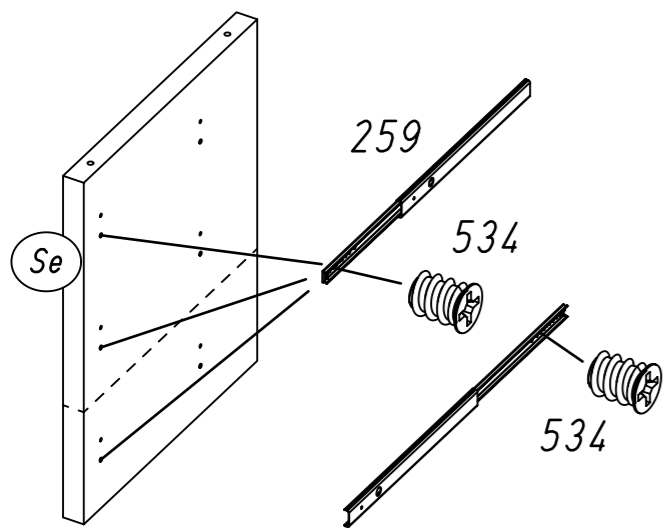
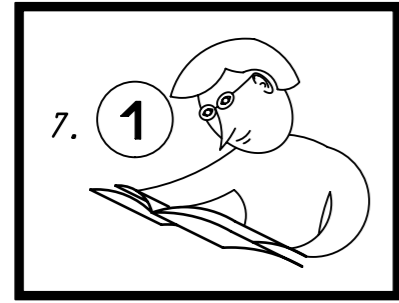

2

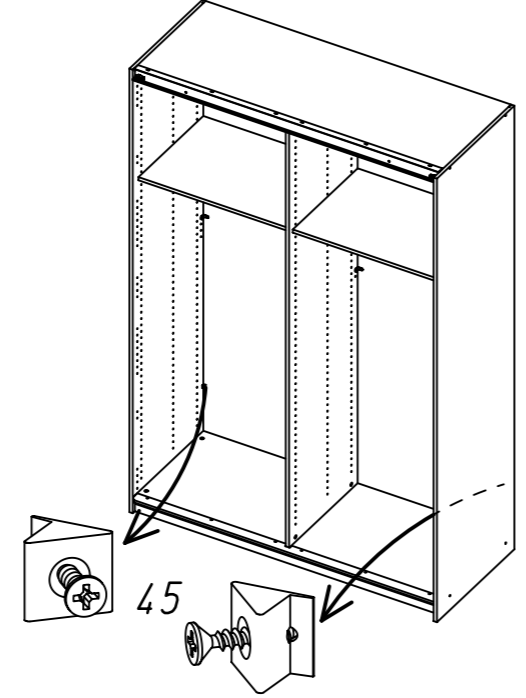

3

220

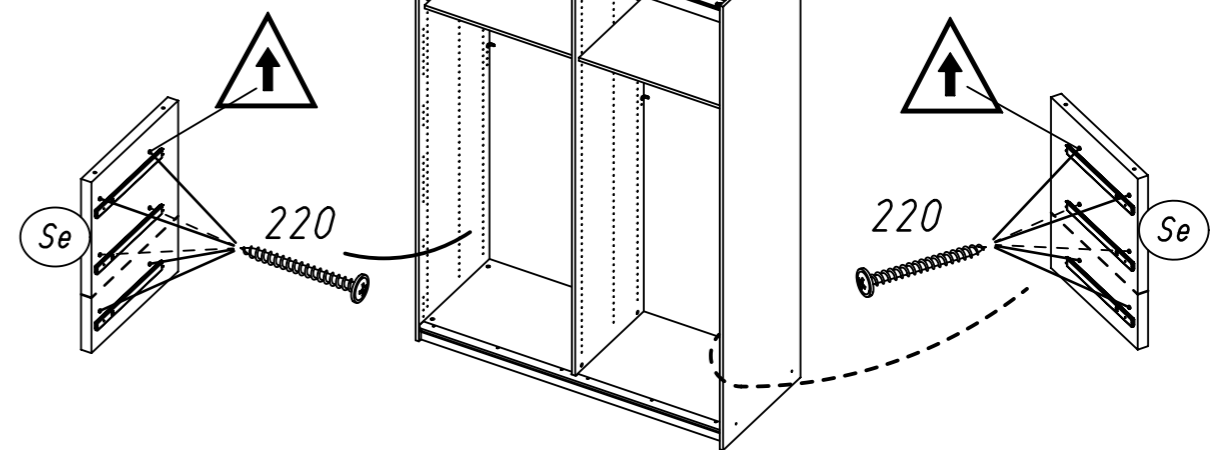

4

807

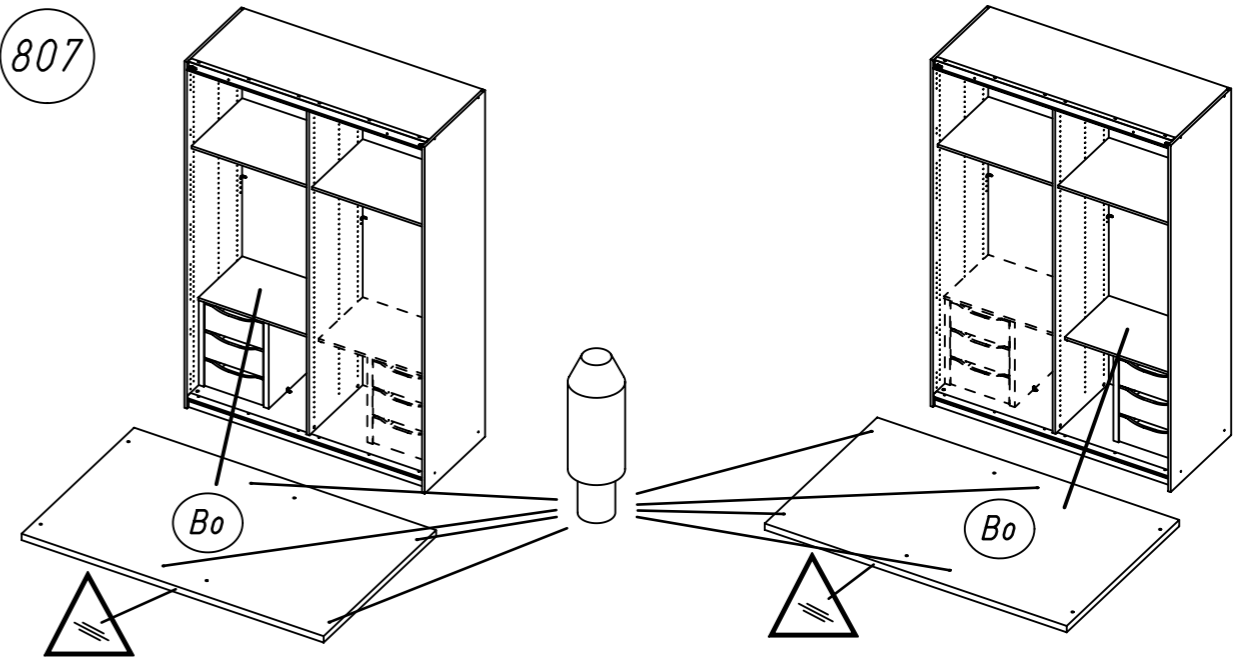

5

